

Die sets made of special grey cast iron

- In numerous standard sizes on stock
- Die sets made of special grey cast iron GGI, alloy (best cutting property) and ultrasonically tested, accordingly without shrinkage, cavities, cracks or inclusions.
- Sliding guides directly in the grey cast iron or guide bushes made of hardened steel with bronze plated running surface.
- Ball guides
- Roller guides

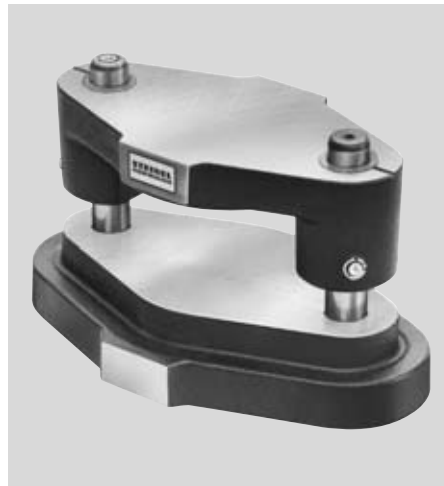

Die sets ST 100.

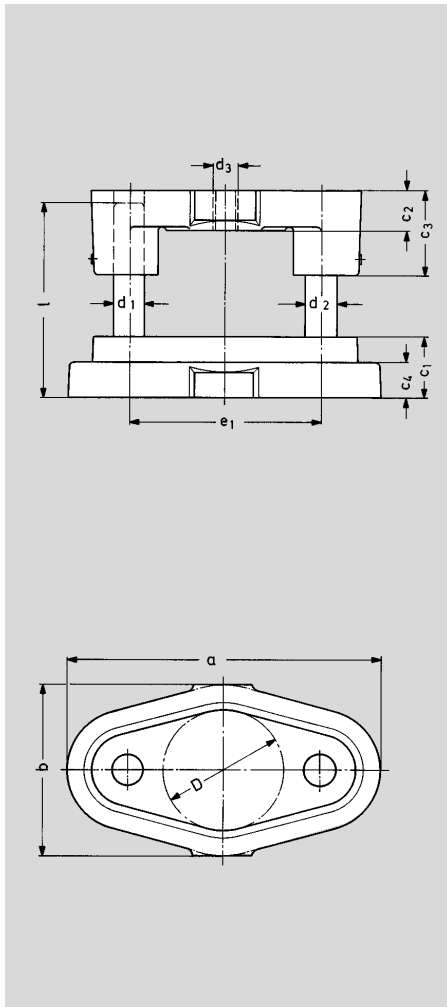

Circular working area
Centrally located pillars
Thin upper plate

DIN 9812

Form D: Upper plate without thread
Form DG: Upper plate with thread

Material: Special grey cast iron GGL alloy ultrasonically tested.

Full scale drawings are available for all die sets sizes at net cost.

For clamping sockets see the appropriate pages.

Order example: Die set with sliding guide, steel bronze plated.
 Upper plate without thread **ST 1001**
 Working area D = 125 mm
 Add **125**
 Order number **ST 1001.125**



Sliding guide
with lubricant

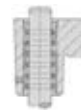

Sliding guide
Hardened steel bush bronze plated



Ball guide
Cage travel = 1/2 length of stroke

Add size to order no.

Upper plate without thread	Order no. ST 1006.	Order no. ST 1001.	Order no. ST 1002.	<input type="checkbox"/>
Upper plate with thread	Order no. ST 1007.	Order no. ST 1004.	Order no. ST 1005.	<input type="checkbox"/>

D	a	b	c ₁	c ₂	c ₃	c ₄	d ₃	e ₁	ST 7100. d ₁ /d ₂ x l	▲
63	171	92	40	25	50	20	M 16 x 1,5	100	15/16 x 140	063
80	217	114	50	30	63	30	M 20 x 1,5	131	19/20 x 160	080
100	263	144	50	30	63	30	M 20 x 1,5	159	24/25 x 160	100
125	288	169	50	30	63	30	M 20 x 1,5	184	24/25 x 160	125
160	345	204	56	40	80	30	M 24 x 1,5	229	30/32 x 180	160
180	366	224	56	40	80	30	M 24 x 1,5	250	30/32 x 180	180
200	385	244	56	40	80	30	M 24 x 1,5	269	30/32 x 200	200
224	448	278	56	50	80	30	M 30 x 2	310	38/40 x 200	224
250	473	304	56	50	80	30	M 30 x 2	335	38/40 x 200	250
280	504	335	63	50	80	30	M 30 x 2	366	38/40 x 224	280
315	539	370	63	50	80	30	M 30 x 2	401	38/40 x 224	315

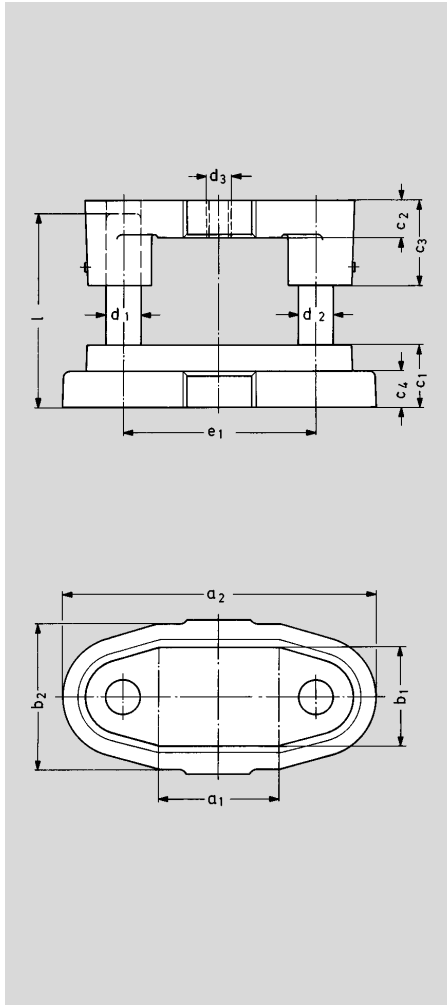

Rectangular working area
Centrally located pillars
Thin upper plate

DIN 9812

Form C: Upper plate without thread
Form CG: Upper plate with thread

Material: Special grey cast iron GGL alloy ultrasonically tested.

Full scale drawings are available for all die sets sizes at net cost.

For clamping sockets see appropriate pages.

Order example: Die set with sliding guide, steel bronze plated.

Upper plate without thread **ST 1201**
 Working area $a_1 \times b_1 = 250 \times 200$ mm
 Add **250 x 200**
 Order number **ST 1201.250 x 200**



Sliding guide
 with
 lubricant

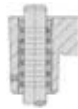

Sliding guide
 Hardened
 steel bushing
 bronze plated



Ball guide
 Cage travel
 = 1/2 length of stroke

Add
 size to
 order no.

Upper plate without thread	Order no. ST 1206.	Order no. ST 1201.	Order no. ST 1202.	<input type="checkbox"/> x <input type="checkbox"/>
Upper plate with thread	Order no. ST 1207.	Order no. ST 1204.	Order no. ST 1205.	<input type="checkbox"/> x <input type="checkbox"/>

$a_1 \times b_1$	a_2	b_2	c_1	c_2	c_3	c_4	d_3	e_1	ST 7100. $d_1/d_2 \times l$	▲
63 x 50	177	74	40	25	50	20	M 16 x 1,5	106	15/16 x 140	063 x 050
80 x 63	217	93	50	30	63	30	M 20 x 1,5	131	19/20 x 160	080 x 063
100 x 63	237	93	50	30	63	30	M 20 x 1,5	151	19/20 x 160	100 x 063
125 x 63	262	93	50	30	63	30	M 20 x 1,5	176	19/20 x 160	125 x 063
100 x 80	263	120	50	30	63	30	M 20 x 1,5	159	24/25 x 160	100 x 080
125 x 80	288	120	50	30	63	30	M 20 x 1,5	184	24/25 x 160	125 x 080
160 x 80	323	120	50	30	63	30	M 20 x 1,5	219	24/25 x 160	160 x 080
125 x 100	288	140	50	40	80	30	M 24 x 1,5	184	24/25 x 180	125 x 100
160 x 100	323	140	50	40	80	30	M 24 x 1,5	219	24/25 x 180	160 x 100
200 x 100	385	140	56	40	80	30	M 24 x 1,5	269	30/32 x 180	200 x 100
160 x 125	345	165	56	40	80	30	M 24 x 1,5	229	30/32 x 180	160 x 125
200 x 125	385	165	56	40	80	30	M 24 x 1,5	269	30/32 x 180	200 x 125
250 x 125	435	165	56	40	80	30	M 24 x 1,5	319	30/32 x 180	250 x 125
200 x 160	385	200	56	50	80	30	M 30 x 2	269	30/32 x 200	200 x 160
250 x 160	435	200	56	50	80	30	M 30 x 2	319	30/32 x 200	250 x 160
315 x 160	545	210	63	50	80	30	M 30 x 2	401	38/40 x 224	315 x 160
250 x 200	479	250	63	50	80	30	M 30 x 2	335	38/40 x 224	250 x 200

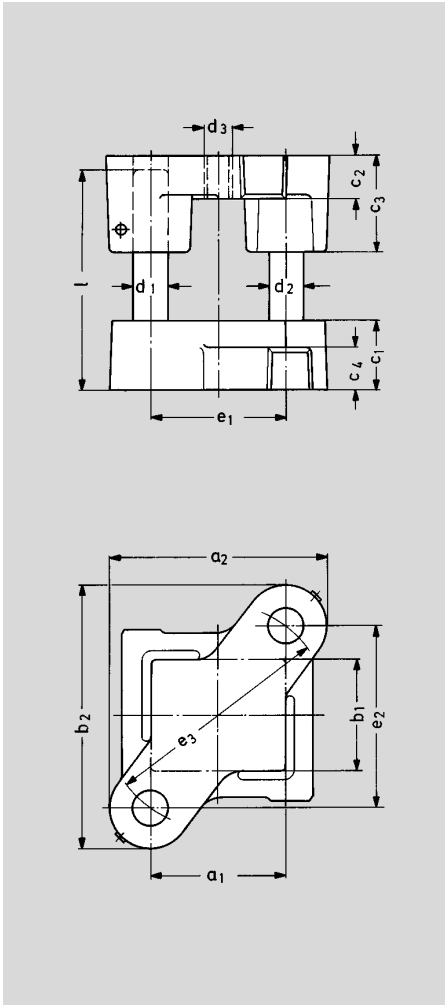

Rectangular working area
Diagonally located pillars
Thin upper plate

DIN 9819

Form C: Upper plate without thread
Form CG: Upper plate with thread

Material: Special grey cast iron GGL alloy ultrasonically tested.

Full scale drawings are available for all die sets sizes at net cost.

For clamping sockets see appropriate pages.

Order example: Die set with sliding guide, steel bronze plated
 Upper plate without thread **ST 1401**
 Working area $a_1 \times b_1 = 200 \times 125$ mm
 Add **200 x 125**
 Order number **ST 1401.200 x 125**



Sliding guide
 with
 lubricant



Sliding guide
 Hardened
 steel bushing
 bronze plated



Ball guide
 Cage travel
 = 1/2 length of stroke

Add
 size to
 order no.

Upper plate without thread	Order no. ST 1406.	Order no. ST 1401.	Order no. ST 1402.	<input type="checkbox"/> x <input type="checkbox"/>
Upper plate with thread	Order no. ST 1407.	Order no. ST 1404.	Order no. ST 1405.	<input type="checkbox"/> x <input type="checkbox"/>

$a_1 \times b_1$	a_2	b_2	c_1	c_2	c_3	c_4	d_3	e_1	e_2	e_3	ST 7100. $d_1/d_2 \times l$	▲
63 x 50	109	131	40	25	50	20	M 16 x 1,5	63,1	85,2	106	15/16 x 140	063 x 050
80 x 63	136	164	50	30	63	30	M 20 x 1,5	80	108	134,4	19/20 x 160	080 x 063
100 x 80	164	197	50	30	63	30	M 20 x 1,5	100	133	166,4	24/25 x 160	100 x 080
125 x 80	189	197	50	30	63	30	M 20 x 1,5	125	133	182,5	24/25 x 160	125 x 080
125 x 100	189	217	50	40	80	30	M 24 x 1,5	125,1	153	197,6	24/25 x 180	125 x 100
160 x 100	225	227	50	40	80	30	M 24 x 1,5	160,9	163	229	24/25 x 180	160 x 100
200 x 100	276	239	56	40	80	30	M 24 x 1,5	200	163	258	30/32 x 180	200 x 100
160 x 125	236	268	56	40	80	30	M 24 x 1,5	160,1	192	250	30/32 x 180	160 x 125
200 x 125	276	264	56	40	80	30	M 24 x 1,5	200	188	274,5	30/32 x 180	200 x 125
250 x 125	326	264	56	40	80	30	M 24 x 1,5	250	188	312,8	30/32 x 180	250 x 125
200 x 160	275	299	56	50	80	30	M 30 x 2	198,7	222,6	298,4	30/32 x 200	200 x 160
250 x 160	326	299	56	50	80	30	M 30 x 2	250	223	335	30/32 x 200	250 x 160
250 x 200	340	370	63	50	80	30	M 30 x 2	250,1	280	375,4	38/40 x 224	250 x 200

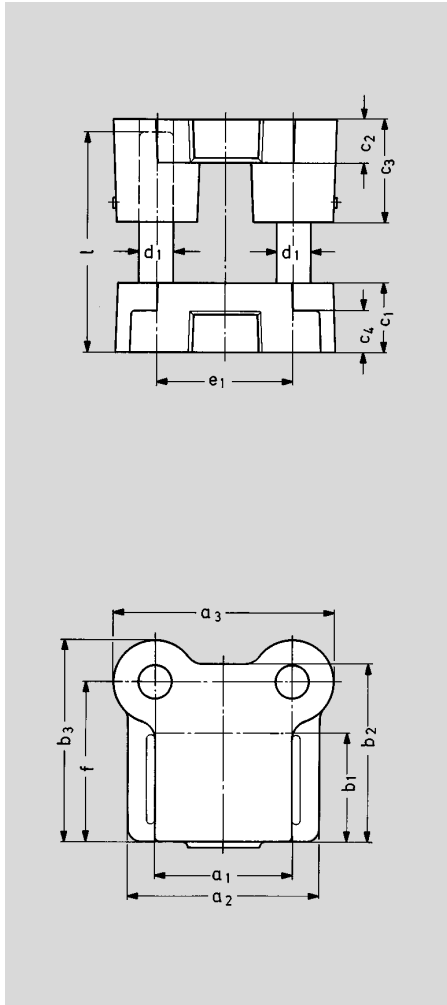

Rectangular working area
Pillars located at rear
Thin upper plate

DIN 9822, form C

Material: Special grey cast iron GGL alloy
 ultrasonically tested.

Full scale drawings are available for all die sets
 sizes at net cost.

For clamping sockets see appropriate pages.

Order example: Die set with ball cage guide
ST 1602

Working area $a_1 \times b_1 = 160 \times 125$ mm

Add **160 x 125**

Order number **ST 1602.160 x 125**



Sliding guide
 with
 lubricant

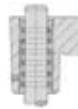

Sliding guide
 Hardened
 steel bushing
 bronze plated



Ball guide
 Cage travel
 = 1/2 length of stroke

Add
 size to
 order no.

Upper plate without thread Order no. **ST 1606.** Order no. **ST 1601.** Order no. **ST 1602.** x

$a_1 \times b_1$	a_2	a_3	b_2	b_3	C_1	C_2	C_3	C_4	e_1	f	ST 7100. $d_1 \times l$	▲
50 x 40	84	118	69	87	36	20	50	20	72	62	16 x 112	050 x 040
63 x 50	97	118	84	102	40	25	50	25	72	77	16 x 125	063 x 050
80 x 50	114	126	84	102	40	25	50	25	80	77	16 x 125	080 x 050
80 x 63	123	136	104	125	45	32	63	30	80	95	19 x 140	080 x 063
100 x 63	143	156	104	125	45	32	63	30	100	95	19 x 140	100 x 063
125 x 63	168	181	104	125	45	32	63	30	125	95	19 x 140	125 x 063
100 x 80	143	164	130	151	50	32	80	30	100	117	25 x 160	100 x 080
125 x 80	168	189	130	151	50	32	80	30	125	117	25 x 160	125 x 080
160 x 80	203	224	130	151	50	32	80	30	160	117	25 x 160	160 x 080
125 x 100	168	201	155	182	56	40	96	30	125	142	32 x 180	125 x 100
160 x 100	203	236	155	182	56	40	96	30	160	142	32 x 180	160 x 100
200 x 100	243	276	155	182	56	40	96	30	200	142	32 x 180	200 x 100
160 x 125	203	236	180	207	56	40	96	30	160	167	32 x 180	160 x 125
200 x 125	243	276	180	207	56	40	96	30	200	167	32 x 180	200 x 125
250 x 125	293	326	180	207	56	40	96	30	250	167	32 x 180	250 x 125
200 x 160	253	288	227	259	63	50	121	30	200	213	40 x 200	200 x 160
250 x 160	303	338	227	259	63	50	121	30	250	213	40 x 200	250 x 160
250 x 200	303	352	266	303	63	50	121	30	250	250	50 x 224	250 x 200
315 x 250	368	412	321	355	63	50	121	30	310	302	50 x 224	315 x 250

Die sets ST 170.

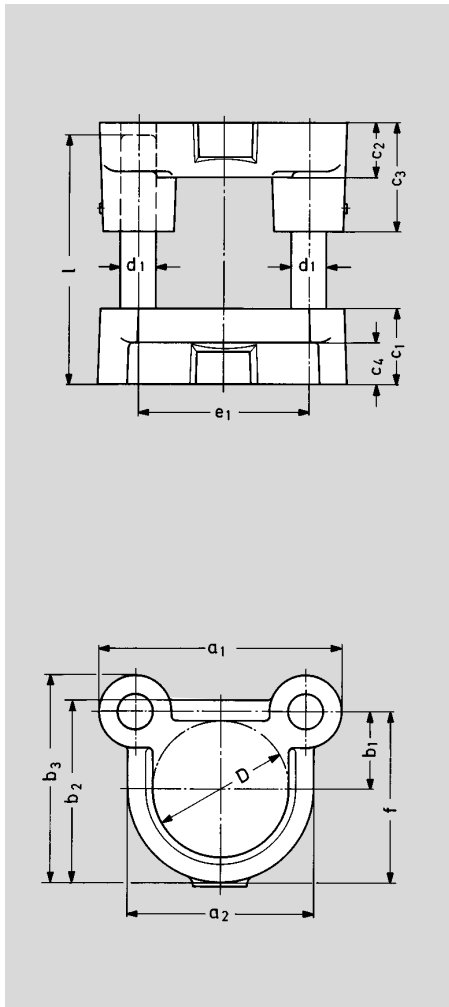

Circular working area
Pillars located at rear
Thin upper plate

DIN 9822, form C

Material: Special grey cast iron GGL alloy ultrasonically tested.

Full scale drawings are available for all die sets sizes at net cost.

For clamping sockets see appropriate pages.

Order example: Die set with sliding guide of full bronze with solid lubrication **ST 1706** Working area $D = 180$ mm.
 Add **180**
 Order number **ST 1706.180**



Sliding guide
with lubricant

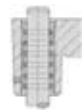

Sliding guide
Hardened steel bushing bronze plated



Ball guide
Cage travel = 1/2 length of stroke

Add size to order no.

Upper plate without thread	Order no. ST 1706.	Order no. ST 1701.	Order no. ST 1702.	<input type="checkbox"/>
----------------------------	---------------------------	---------------------------	---------------------------	--------------------------

D	a ₁	a ₂ ~	b ₁	b ₂ ~	b ₃ ~	C ₁	C ₂	C ₃	C ₄	e ₁	f	ST 7100. d ₁ x l	▲
63	136	95	40	92	115	45	32	63	25	80	87	19 x 125	063
80	164	112	50	112	138	50	32	63	30	100	106	25 x 140	080
100	189	138	56	134	157	56	40	80	30	125	125	25 x 160	100
125	236	168	63	164	185	56	40	80	30	160	147	32 x 180	125
160	288	204	80	202	226	56	50	100	30	200	182	40 x 200	160
180	307	224	85	222	241	63	50	100	30	219	197	40 x 200	180

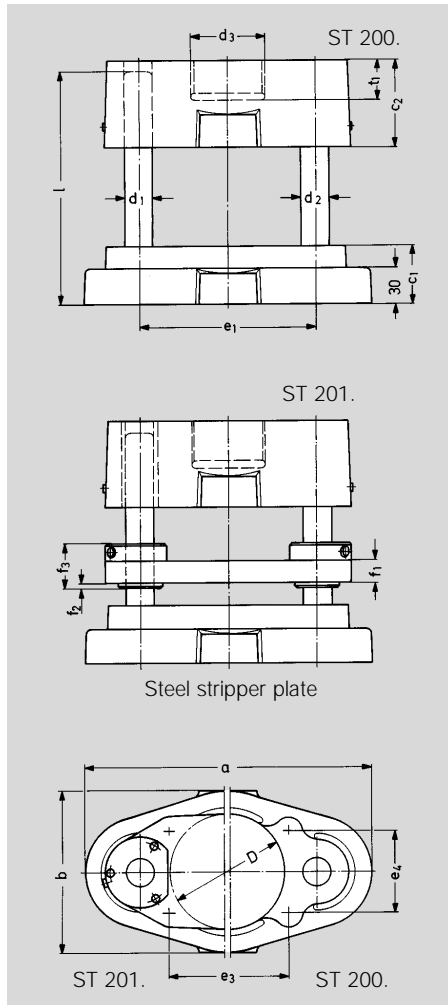

Circular working area
Centrally located pillars
Thick upper plate
Moveable stripper plate available upon request

Similar DIN 9816

Form D: without stripper plate
Form DF: with stripper plate

Material: Special grey cast iron GGL alloy ultrasonically tested.

Full scale drawings are available for all die sets sizes at net cost.

For clamping sockets see appropriate pages.

Order example: Die set with sliding guide, steel bronze plated with steel stripper plate
 Upper plate without thread **ST 2011**
 Working area D = 125 mm
 Add **125**
 Order number **ST 2011.125**



Sliding guide
 with lubricant



Sliding guide
 Hardened steel bushing bronze plated in upper plate and stripper plate



Ball guide
 in upper plate and stripper plate
 Cage travel = 1/2 length of stroke

Stripper plate	Upper plate													ST 7100. d ₁ /d ₂ x l	Add size to order no.
-	without thread	Order no. ST 2006.	Order no. ST 2001.	Order no. ST 2002.											<input type="checkbox"/>
-	with thread	Order no. ST 2007.*)	Order no. ST 2004.*)	Order no. ST 2005.*)											<input type="checkbox"/>
Steel	without thread	-	Order no. ST 2011.	Order no. ST 2012.											<input type="checkbox"/>
Steel	with thread	-	Order no. ST 2014.*)	Order no. ST 2015.*)											<input type="checkbox"/>

D	a	b	c ₁	c ₂	d ₃ *)	e ₁	e ₃	e ₄	f ₁	f ₂	f ₃	t ₁	ST 7100. d ₁ /d ₂ x l	▲
80	218	125	50	63	-	122	85	60	16	7	38	-	19/20 x 200	080
100	258	144	50	80	M 64 x 4	154	105	70	18	5	38	35	24/25 x 200	100
125	283	169	56	80	M 84 x 4	179	135	80	18	5	38	41	24/25 x 224	125
160	345	204	63	100	M 104 x 4	229	170	90	22	8	45	50	30/32 x 250	160

*) available with pocket for spring acc. to d₃ at surcharge.

Die sets ST 286.

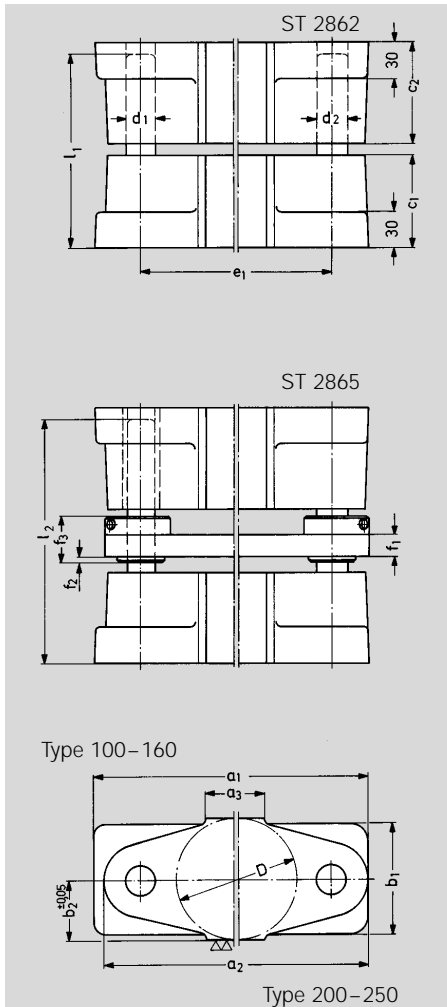

Circular working area
Centrally located pillars
Bearing surface lateral

Fine-blanking die set

Application: execution **without stripper plate ST 2862** for construction of fine-blanking tools with moveable punches.
 Execution **with stripper plate ST 2865** for construction of fine blanking tools with fixed punches. Deliverable with recesses upon request.

Material: Special grey cast iron GGL alloy ultrasonically tested.

Full scale drawings are available for all die sets sizes at cost price, see appropriate pages.

Order example: Die set with ball guide without stripper plate **ST 2862**
 Working area D = 200 mm
 Add **200**
 Order number **ST 2862.200**



Ball guide

in upper plate and stripper plate
 Cage travel = 1/2 length of stroke

Add size to order no.

Stripper plate	Upper plate	Order no.	
-	without thread	Order no. ST 2862.	<input type="checkbox"/>
Steel	without thread	Order no. ST 2865.	<input type="checkbox"/>

D	a ₁	a ₂	a ₃	b ₁	b ₂	c ₁	c ₂	e ₁	f ₁	f ₂	f ₃	ST 7100. d ₁ /d ₂ x l ₁	ST 7100. d ₁ /d ₂ x l ₂	▲
100	237	219	50	92	50	75	80	159	18	5	38	24/25 x 160	24/25 x 200	100
125	262	244	60	107	62,5	75	80	184	18	5	38	24/25 x 160	24/25 x 200	125
160	328	301	70	142	80	75	80	229	22	8	45	30/32 x 160	30/32 x 200	160
200	347	341	90	167	100	80	100	269	22	8	45	30/32 x 200	30/32 x 224	200
250	425	419	100	222	125	85	100	335	28	2	55	38/40 x 200	38/40 x 250	250

Acceptance specifications

for die sets made of special grey cast iron



DIN 9811 part 1

Dimensions without tolerance declaration

For cast unfinished surfaces:
DIN 1686 – GTB 17

For finished surfaces:
DIN 7168 – middle

Tolerances of planeness, parallelism and rectangularity

	Test piece	Testing position	Largest length of the working area		Testing data T_P, T_E, T_R
			over	to	
Flatness of surface			—	—	0,005 to 100 mm length of the working area *)
Parallelism of surface pairs			0	100	0,005
			100	200	0,008
			200	300	0,011
			300	400	0,014
			400	500	0,017
			500	600	0,020
Parallelism of bearing surfaces			0	100	0,008
			100	200	0,012
			200	300	0,018
			300	400	0,024
			400	500	0,030
			500	600	0,036
Squareness of guide pillars			—	—	0,005 to 100 mm length of the working area *)

*)When testing larger or smaller lengths, multiply tolerance value accordingly with the relevant factor.

Steinel precision sliding guides

with solid lubricant

STEINEL
NORMALIEN®

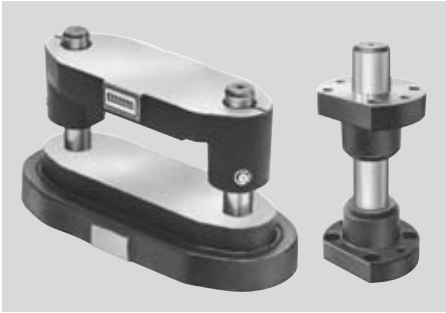

Fields of application

Steinel precision sliding guides with "solid lubricant" can be used for tool and fixture manufacturing in various fitting positions for longitudinal motions.

Structure

The Steinel precision sliding guide "with solid lubricant" is composed of:
Guide pillar and die set upper plate made of grey cast iron of special type resp. guide bearing with built-in solid lubricant bushes.



Material:

Steel with lubricant cups

These sliding guides are self-lubricating due to the presence of built in lubrication cups, thereby also increasing their pressure tolerance.

Our maintenance-free, self-lubricating bearing bush is complex and highly wear resistant. It has embedded in it various lubricating materials such as molybdenum, disulfate and graphite in appropriate form.

It thereby differs from other sinter bearing bushes, which are commonly considered oil-free bearings.

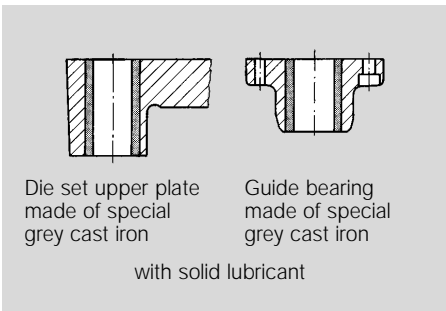

Lubrication with solid lubricant

The lubrication with solid lubricant is designated as state of lubrication where solid lubricant particles having a low cutting resistance in their crystalline structure exist between two surfaces and their adopt the lubrication function.

Sliding speed

The max. sliding speed is at 30 m / min.

With ideal lubrication, ideal guide clearance and length of stroke, ideal radial load and heat dissipation the Steinel precision sliding guide "with solid lubricant" allows stroke speeds of 600 – 800 strokes/min.

Guide clearance

The guide clearance is 2 – 7 µm. If you require more clearance, please specify in your order f.e. "Honed for easy slide fit".

Advantages:

In the automatic systems you avoid corrodors which can arise due to a lack of maintenance.

The maintenance is generally eased because there is simply no longer a lubrication required.

Safety and cleanliness in the environment of production are essentially increased as there is no lubrication made any more.

Reduction of the number of required parts on the devices due to the discontinuance of the central lubrication systems whereby the costs for mounting resp. assembling are reduced.

You can save time already during constructions when you no longer require the lubricating system.

Hints for installation:

1st Glue into fixing bore hole ISO H6 (see to conc. page for bonding agent)

2nd Avoid to press in lest inner diameter becomes more narrow.

Guidance diameter ISO H6 precision turned
Fixing bore hole ISO j6 precision turned.