

INDEX

MONO RAIL:	
NEW ROLLON BALL RECIRCULATING LINEAR GUIDES.....	3
MRS SERIES (standard slider).....	4
MRT SERIES (low profile slider).....	5
TECHNICAL DATA:	
MRS SERIES (with flange).....	6
MRS SERIES (without flange).....	7
MRT SERIES (with flange).....	8
MRT SERIES (without flange).....	9
LOAD CAPACITY, PRELOAD / RADIAL CLEARANCE.....	10
LINEAR PRECISION.....	11
LIFETIME.....	12
VERIFICATION UNDER STATIC LOAD.....	13
MOUNTING METHODS.....	14
MOUNTING PRECISION.....	14
MOUNTING PROCEDURE.....	15
FIXING EXAMPLES.....	16
ORDER CODES.....	17

MONO RAIL: NEW ROLLON BALL RECIRCULATING LINEAR GUIDES

ROLLON introduces its new 4-rows circular contact ball recirculating linear guides in the **MONO RAIL** family.

This new family is added to the well-known **COMPACT RAIL**, **TELESCOPIC RAIL**, **EASY RAIL**, **UNILINE**, **ECOLINE**, **CURVILINE**, **LIGHT RAIL** families, widening again the product range in order to offer 360° solutions to industrial linear motion problems. As usual in **ROLLON**, this new family maintains the large reliability characteristics that have always been the Company 'trade-mark'. **ROLLON** offers **MONO RAIL** linear guides in seven different sizes, from section **15 mm** as far as section **55 mm**.

Sliders are available in two different series, depending from main section profile (**standard version** and **low profile version**), subdivided in two variants following the slider shape (**with** and **without flanges**).

Slider configurations differ in:

- **Fixing holes** (threaded or cylindrical holes)
- **Slider length** (normal, long, short).
- **Linear precision** (normal, high, precision, super-precision, ultra-precision)
- **Preload** (clearance, no-preload, light-preload, middle-preload, heavy-preload)

Rails and sliders are hardened and ground, moreover every slider mounts a self-lubricating device that, raising lubrication intervals, reduces maintenance costs.

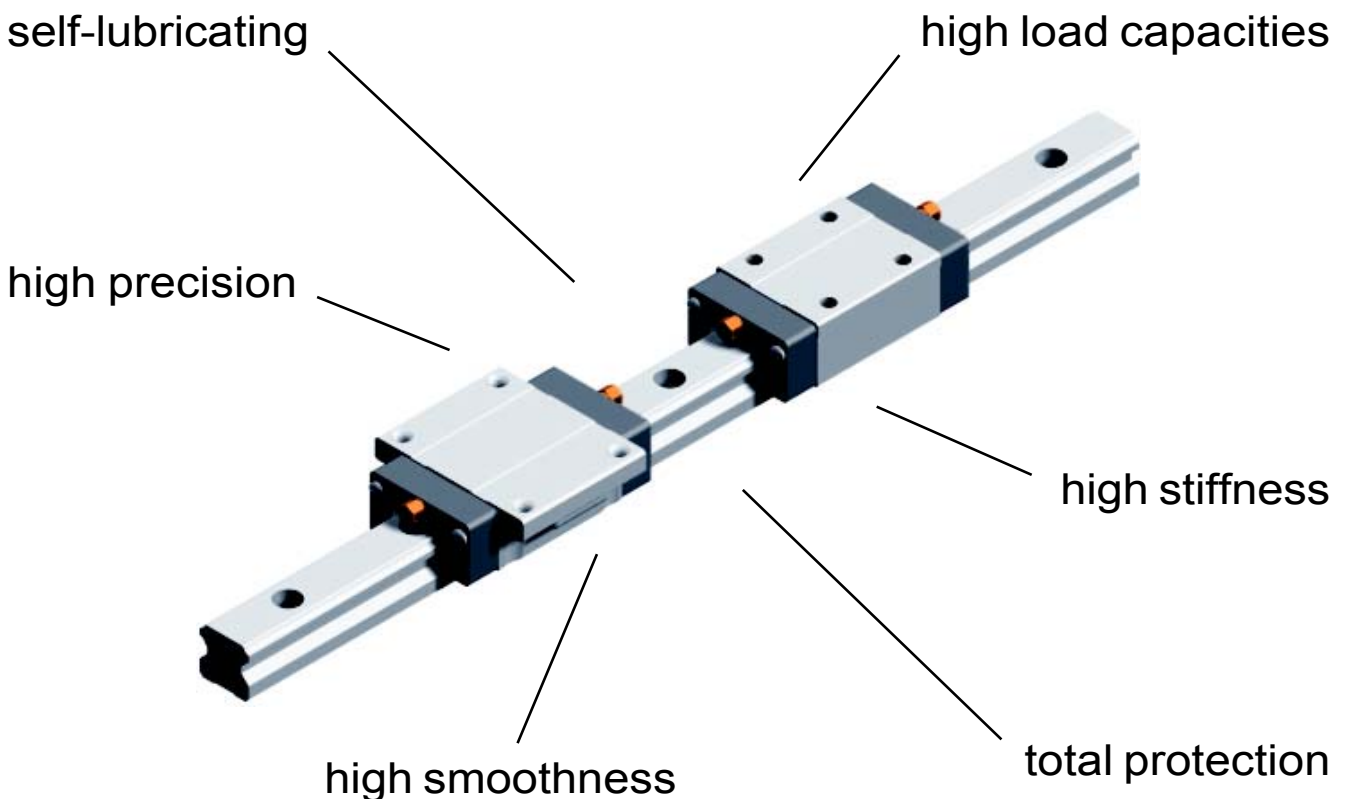

CONTACT ANGLES



MRS SERIES (standard slider)

It's a 4-rows circular contact ball recirculating slider with a self-lubricating system coupled with a rail, all hardened and ground. It's available in two variants (with or without flanges). For all technical information (sizes, load capacities, etc.) see page 6 and page 10. Order codes on page 17.

List of components:

1. Rail
2. Grease nipple
3. Slider body
4. Head
5. Self-lubricant elements
6. Head cap
7. Low seal (on request)

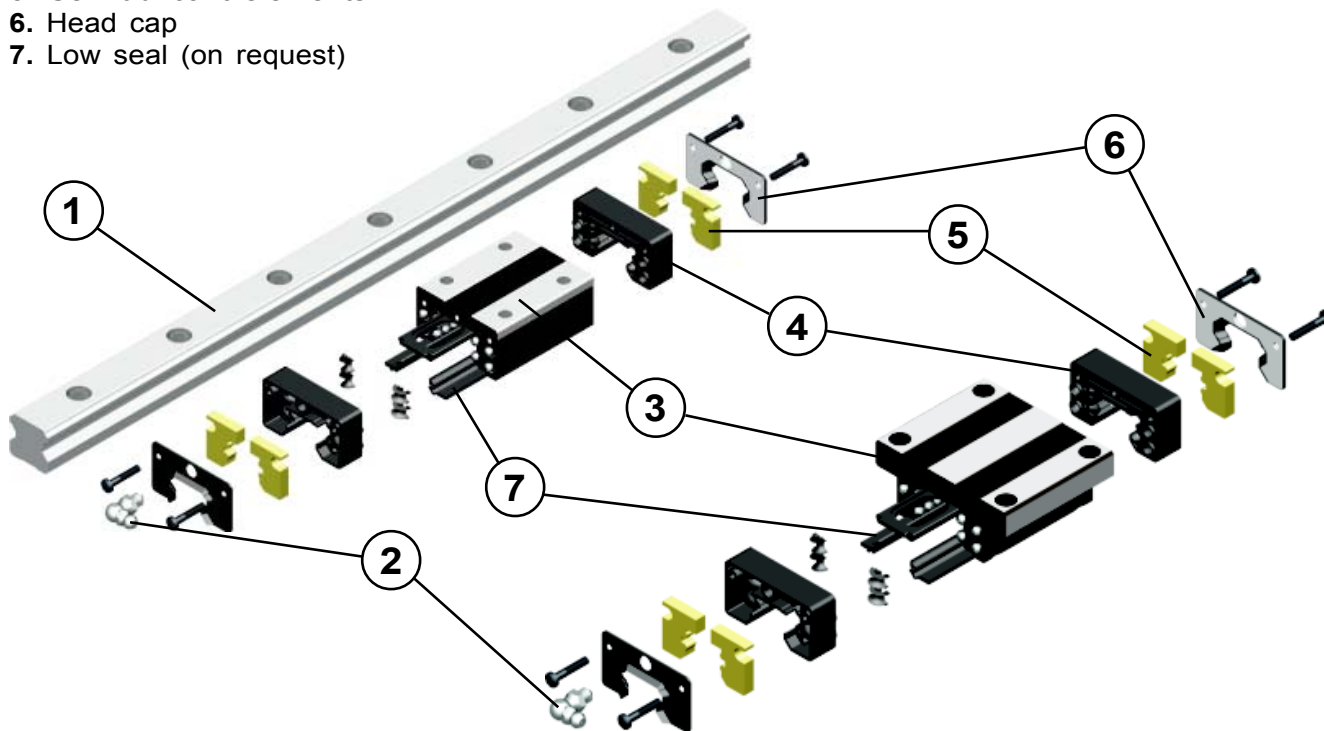

Available sizes:

MRS..

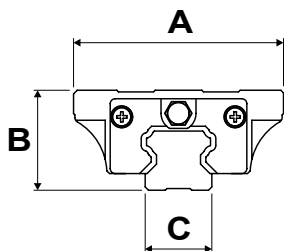

Type	A (mm)	B (mm)	C (mm)
MRS15	47	24	15
MRS20	63	30	20
MRS25	70	36	23
MRS30	90	42	28
MRS35	100	48	34
MRS45	120	60	45
MRS55	140	70	53

MRS..W

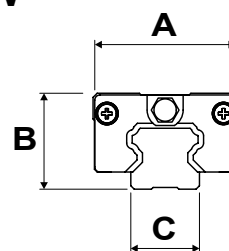

Type	A (mm)	B (mm)	C (mm)
MRS15W	34	28	15
MRS20W	44	30	20
MRS25W	48	40	23
MRS30W	60	45	28
MRS35W	70	55	34
MRS45W	86	70	45
MRS55W	100	80	53

MRT SERIES (low profile slider)

It's a 4-rows circular contact ball recirculating slider with a self-lubricating system coupled with a rail, all hardened and ground. It's available in two variants (with or without flanges).

It's from MRS series for height overall dimensions (mounted rail/slider).

For all technical information (sizes, load capacities, etc.) see page 8 and page 10.

Order codes on page 17.

List of components:

1. Rail
2. Grease nipple
3. Slider body
4. Head
5. Self-lubricant elements
6. Head cap
7. Low seal (on request)

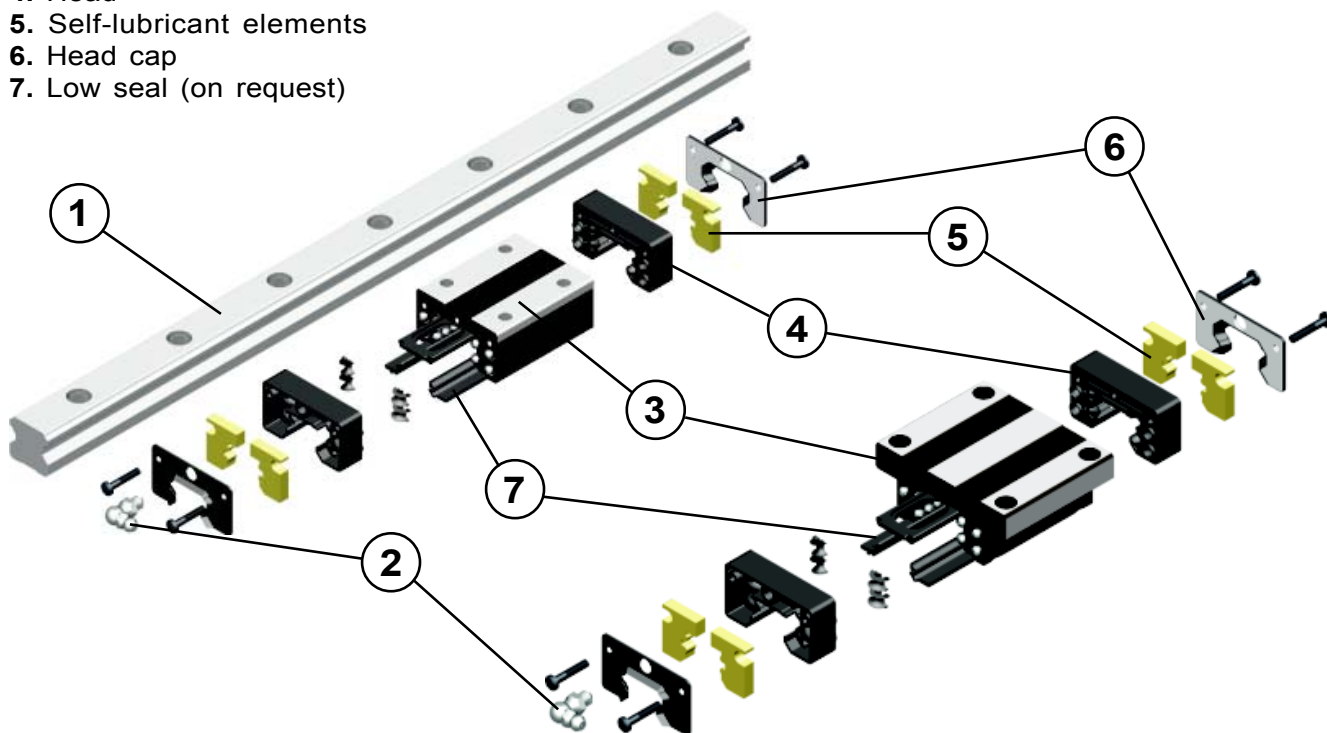

Available sizes:

MRT..

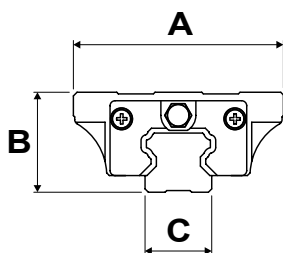

Type	A (mm)	B (mm)	C (mm)
MRT20	59	28	20
MRT25	73	33	23

MRT..W

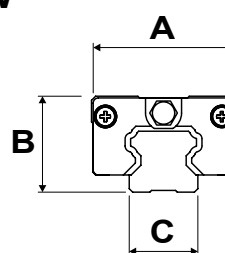

Type	A (mm)	B (mm)	C (mm)
MRT15W	34	24	15
MRT20W	42	28	20
MRT25W	48	33	23
MRT30W	60	42	28
MRT35W	70	48	34
MRT45W	86	60	45
MRT55W	100	68	53

TECHNICAL DATA

MRS Series (with flange)

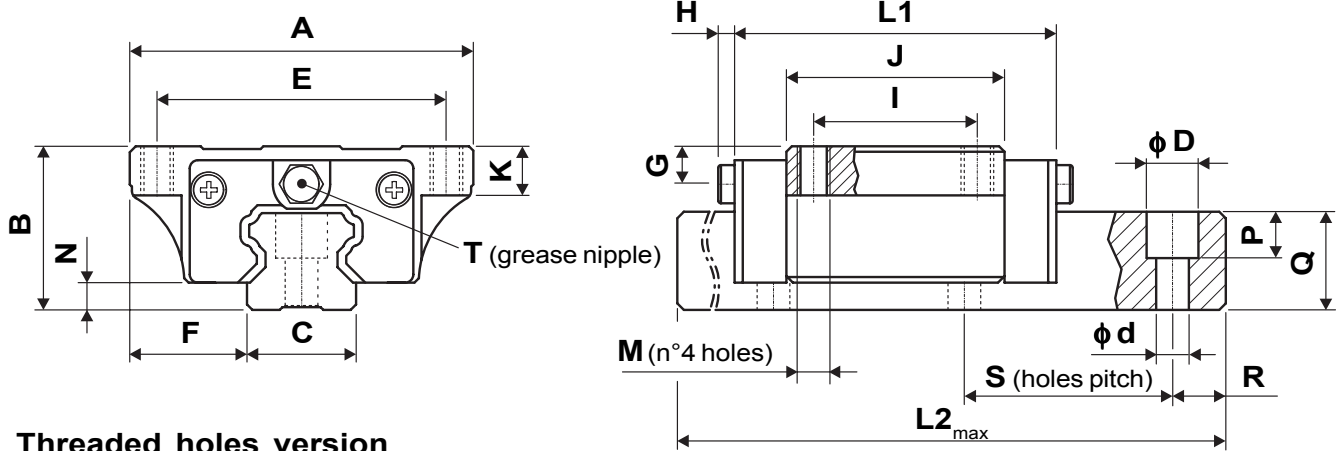

Threaded holes version

TYPE	ASSEMBLY [mm]				SLIDER (MRS) * [mm]									RAIL (MRR) * [mm]							WEIGHT		
	A	B	F	N	L1	J	M	K	E	I	H	G	T	C	Q	D	d	P	S	R	L2 (max)	Slider [kg]	Rail [kg/m]
MRS15	47	24	16	4.6	66	40	M5	8	38	30	5	4.3	$\phi 3$	15	14	7.5	4.5	5.3	60	20	4000	0.19	1.4
MRS20	63	30	21.5	5	77.8	48.8	M6	9	53	40	6.5	5	M6x1	20	18	9.5	6	8.5	60	20	4000	0.4	2.6
MRS20L					92.4	63.4																0.52	
MRS25	70	36	23.5	7	88	57	M8	12	57	45	6.5	5	M6x1	23	22	11	7	9	60	20	4000	0.57	3.6
MRS25L					110.1	79.1																0.72	
MRS30	90	42	31	9	109	72	M10	12	72	52	6.5	7	M6x1	28	26	14	9	12	80	20	3960	1.1	5.2
MRS30L					131.3	94.3																1.4	
MRS35	100	48	33	9.5	119	80	M10	13	82	62	6.5	8	M6x1	34	29	14	9	12	80	20	3960	1.6	7.2
MRS35L					144.8	105.8																2	
MRS45	120	60	37.5	14	148.2	105	M12	15	100	80	13	10	M8x1	45	38	20	14	17	105	22.5	3930	2.7	12.3
MRS45L					173	129.8																3.6	
MRS55	140	70	43.5	12.7	181	131	M14	21	116	95	13	20	M8x1	53	38	23	16	20	120	30	3900	5.4	14.5
MRS55L					223	173																7.1	

* For order codes see page 17

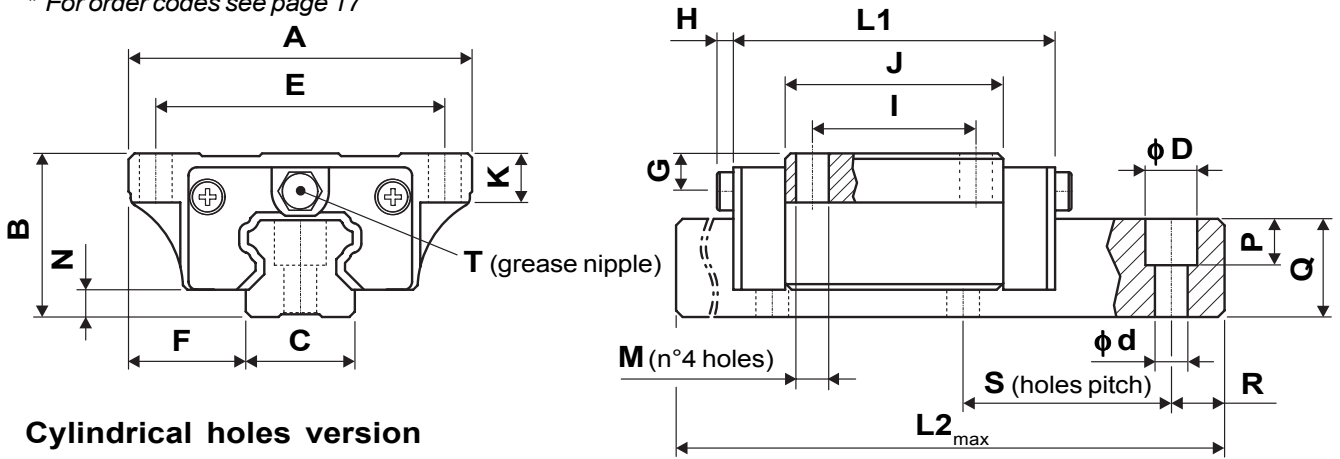

Cylindrical holes version

TYPE	ASSEMBLY [mm]				SLIDER (MRS) * [mm]									RAIL (MRR) * [mm]							WEIGHT		
	A	B	F	N	L1	J	M	K	E	I	H	G	T	C	Q	D	d	P	S	R	L2 (max)	Slider [kg]	Rail [kg/m]
MRS15C	47	24	16	4.6	66	40	$\phi 4.5$	8	38	30	5	4.3	$\phi 3$	15	14	7.5	4.5	5.3	60	20	4000	0.19	1.4
MRS20C	63	30	21.5	5	77.8	48.8	$\phi 5.5$	9	53	40	6.5	5	M6x1	20	18	9.5	6	8.5	60	20	4000	0.4	2.6
MRS20LC					92.4	63.4																0.52	
MRS25C	70	36	23.5	7	88	57	$\phi 7$	12	57	45	6.5	5	M6x1	23	22	11	7	9	60	20	4000	0.57	3.6
MRS25LC					110.1	79.1																0.72	
MRS30C	90	42	31	9	109	72	$\phi 9$	12	72	52	6.5	7	M6x1	28	26	14	9	12	80	20	3960	1.1	5.2
MRS30LC					131.3	94.3																1.4	

* For order codes see page 17

TECHNICAL DATA

MRS Series (without flange)

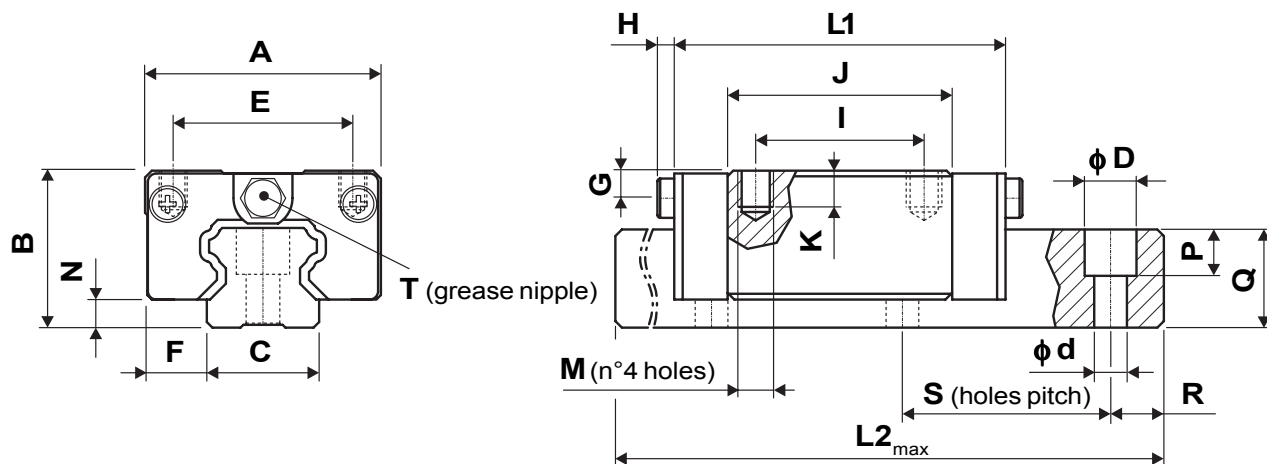

Threaded holes version

TYPE	ASSEMBLY [mm]				SLIDER (MRS) * [mm]								RAIL (MRR) * [mm]							WEIGHT			
	A	B	F	N	L1	J	M	K	E	I	H	G	T	C	Q	D	d	P	S	R	L2 (max)	Slider [kg]	Rail [kg/m]
MRS15W	34	28	9.5	4.6	66	40	M4	6.4	26	26	5	8.3	φ3	15	14	7.5	4.5	5.3	60	20	4000	0.21	1.4
MRS20W	44	30	12	5	77.8	48.8	M5	8	32	36	6.5	7	M6x1	20	18	9.5	6	8.5	60	20	4000	0.31	2.6
MRS20LW					92.4	63.4			32	50													
MRS25W	48	40	12.5	7	88	57	M6	9.6	35	35	6.5	11.8	M6x1	23	22	11	7	9	60	20	4000	0.45	3.6
MRS25LW					110.1	79.1			35	50													
MRS30W	60	45	16	9	109	72	M8	12.8	40	40	6.5	10	M6x1	28	26	14	9	12	80	20	3960	0.91	5.2
MRS30LW					131.3	94.3			40	60													
MRS35W	70	55	18	9.5	119	80	M8	12.8	50	50	6.5	15	M6x1	34	29	14	9	12	80	20	3960	1.5	7.2
MRS35LW					144.8	105.8			50	72													
MRS45W	86	70	20.5	14	148.2	105	M10	16	60	60	13	18	M8x1	45	38	20	14	17	105	22.5	3930	2.3	12.3
MRS45LW					173	129.8			60	80													
MRS55W	100	80	23.5	12.7	181	131	M12	19	75	75	13	30	M8x1	53	38	23	16	20	120	30	3900	5.2	14.5
MRS55LW					223	173			75	95													

* For order codes see page 17

TECHNICAL DATA

MRT Series (with flange)

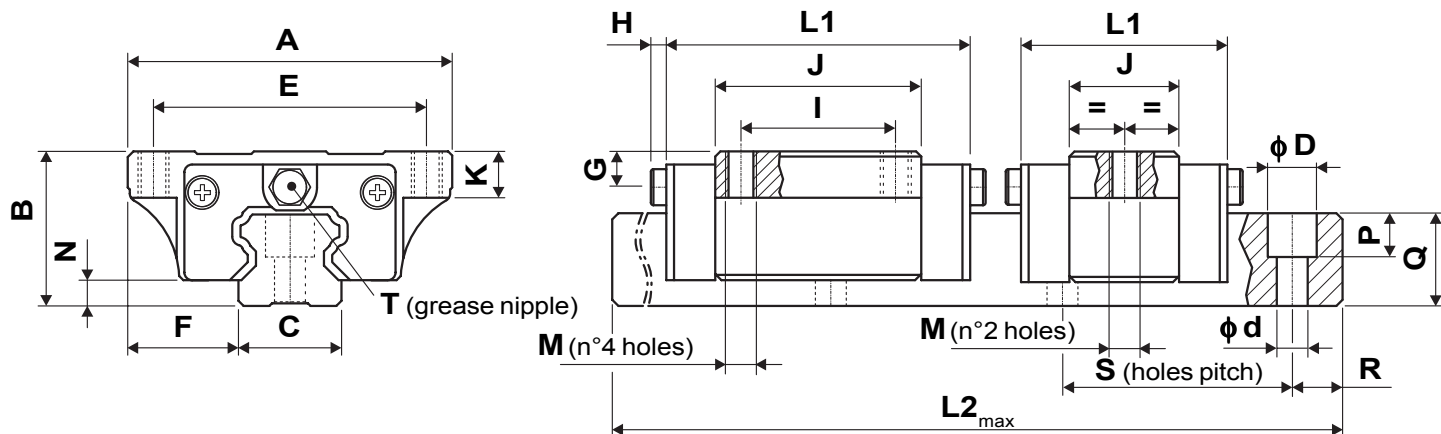

Threaded holes version

TYPE	ASSEMBLY [mm]				SLIDER (MRT) * [mm]									RAIL (MRR) * [mm]							WEIGHT		
	A	B	F	N	L1	J	M	K	E	I	H	G	T	C	Q	D	d	P	S	R	L2 (max)	Slider [kg]	Rail [kg/m]
MRT20S	59	28	19.5	5	57	28	M6	7	49	-	6.5	5	M6x1	20	18	9.5	6	8.5	60	20	4000	0.17	2.6
MRT25	73	33	25	7	88	57	M8	9	60	35	6.5	4.8	M6x1	23	22	11	7	9	60	20	4000	0.5	3.6
MRT25S					62.5	31.5				-												0.33	

* For order codes see page 17

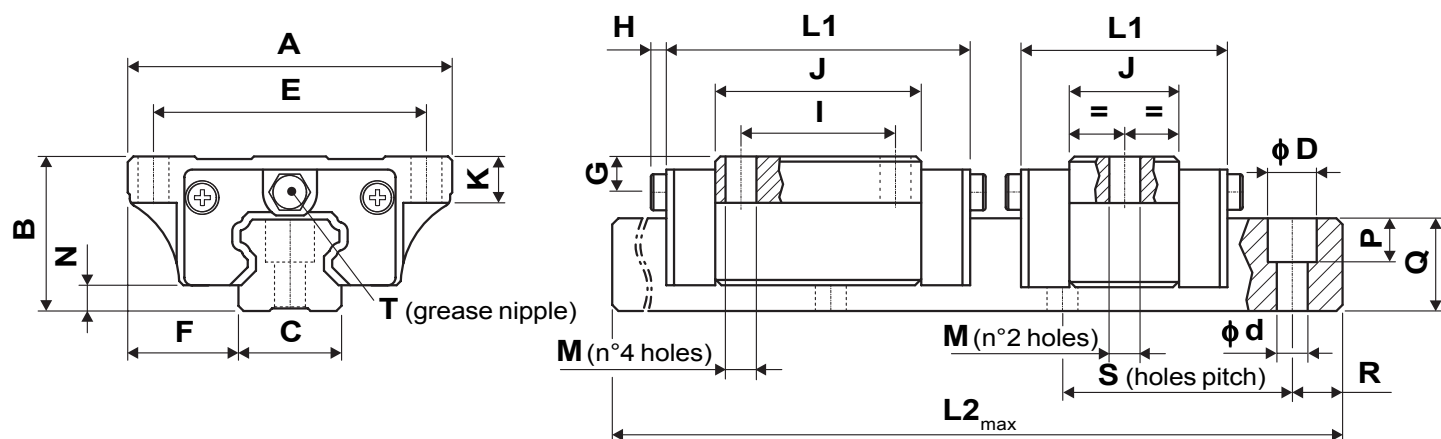

Cylindrical holes version

TYPE	ASSEMBLY [mm]				SLIDER (MRT) * [mm]									RAIL (MRR) * [mm]							WEIGHT		
	A	B	F	N	L1	J	M	K	E	I	H	G	T	C	Q	D	d	P	S	R	L2 (max)	Slider [kg]	Rail [kg/m]
MRT20SC	59	28	19.5	5	57	28	$\phi 5.5$	7	49	-	6.5	5	M6x1	20	18	9.5	6	8.5	60	20	4000	0.17	2.6
MRT25C	73	33	25	7	88	57	$\phi 7$	9	60	35	6.5	4.8	M6x1	23	22	11	7	9	60	20	4000	0.5	3.6
MRT25SC					62.5	31.5				-												0.33	

* For order codes see page 17

TECHNICAL DATA

MRT Series (without flange)

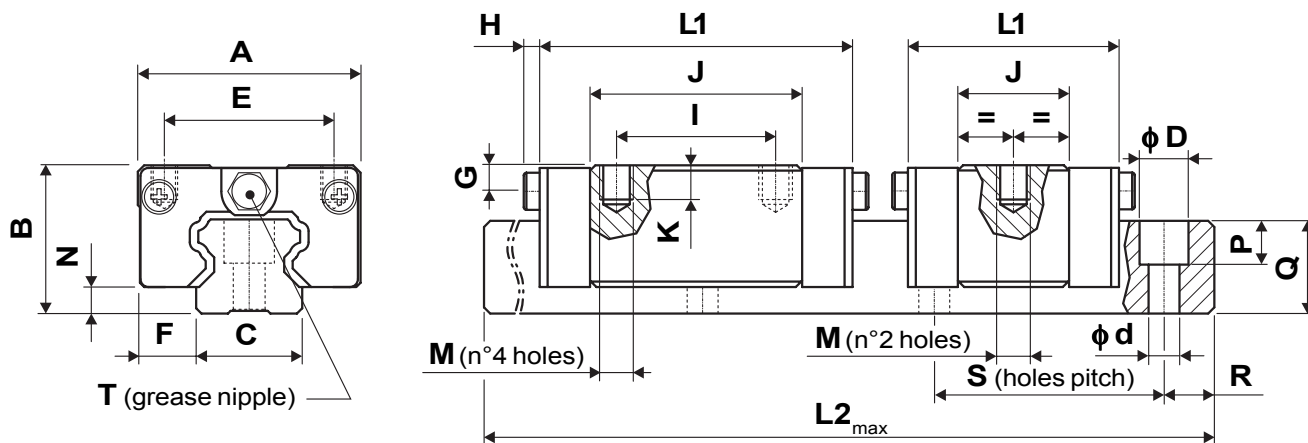

Threaded holes version

TYPE	ASSEMBLY [mm]				SLIDER (MRT) * [mm]								RAIL (MRR) * [mm]							WEIGHT																				
	A	B	F	N	L1	J	M	K	E	I	H	G	T	C	Q	D	d	P	S	R	L2 (max)	Slider [kg]	Rail [kg/m]																	
MRT15W	34	24	9.5	4.6	66	40	M4	5.6	26	26	5	4.3	φ3	15	14	7.5	4.5	5.3	60	20	4000	0.17	1.4																	
MRT15SW					47.6	21.6			26	-																										0.1				
MRT20W	42	28	11	5	77.8	48.8	M5	7	32	32	6.5	5	M6x1	20	18	9.5	6	8.5	60	20	4000	0.26	2.6																	
MRT20SW					58	28			32	-																										0.17				
MRT25W	48	33	12.5	7	88	57	M6	8.4	35	35	6.5	4.8	M6x1	23	22	11	7	9	60	20	4000	0.38	3.6																	
MRT25SW					62.5	31.5			35	-																													0.21	
MRT25LW					110.1	79.1			35	50																														0.53
MRT30W	60	42	16	9	109	72	M8	11.2	40	40	6.5	7	M6x1	28	26	14	9	12	80	20	3960	0.81	5.2																	
MRT30SW					75.6	38.6			40	-																													0.48	
MRT30LW					131.3	94.3			40	60																														1.06
MRT35W	70	48	18	9.5	119	80	M8	11.2	50	50	6.5	8	M6x1	34	29	14	9	12	80	20	3960	1.2	7.2																	
MRT35SW					84.7	45.7			50	-																													0.8	
MRT35LW					144.8	105.8			50	72																														1.6
MRT45W	86	60	20.5	14	148.2	105	M10	14	60	60	13	8.5	M8x1	45	38	20	14	17	105	22.5	3930	2.1	12.3																	
MRT45LW					173	129.8			60	80																													2.6	
MRT55W	100	68	23.5	12.7	181	131	M12	15	75	75	13	18	M8x1	53	38	23	16	20	120	30	3900	5	14.5																	
MRT55LW					223	173			75	95																														6.5

* For order codes see page 17

LOAD CAPACITIES

In the table below are indicated load capacities for each slider type. Axial and radial static capacity loads are the same. This is true because of the 4-rows circular contact ball recirculating system (45° contact angles). For more information, please contact our Application Engineering Department.

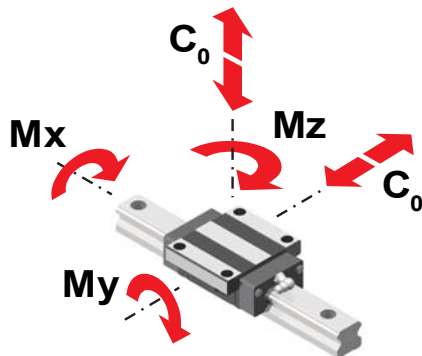

TYPE	LOAD CAPACITIES [N]		STATIC MOMENTS [Nm]		
	Dynamic Load (C)	Static Load (C ₀)	Mx	My	Mz
MRS15 MRS15C MRS15W MRT15W	8500	16500	100	80	80
MRT15SW	5100	9500	60	48	48
MRS20 MRS20C MRS20W MRT20W	14500	25600	220	180	180
MRT20S MRS20SC MRS20SW	8300	14700	126	103	103
MRS20L MRS20LC MRS20LW	19000	33300	286	234	234
MRS25 MRS25C MRT25 MRT25C MRS25W MRT25W	21400	40000	360	320	310
MRT25S MRT25SC MRT25SW	11900	22300	200	175	172
MRS25L MRS25LC MRS25LW MRT25LW	29960	56000	504	448	434

TYPE	LOAD CAPACITIES [N]		STATIC MOMENTS [Nm]		
	Dynamic Load (C)	Static Load (C ₀)	Mx	My	Mz
MRS30 MRS30C MRS30W MRT30W	29800	54900	600	500	490
MRT30SW	15950	29400	320	270	270
MRS30L MRS30LC	39000	71900	785	650	650
MRS35 MRS35W MRT35W	39600	70100	960	750	730
MRT35SW	22600	40000	545	425	415
MRS35L MRS35LW MRT35LW	52300	92700	1250	950	950
MRS45 MRS45W MRT45W	67400	121000	2160	1700	1680
MRS45L MRS45LW MRT45LW	83300	149500	2670	2100	2100
MRS55 MRS55W MRT55W	123500	190000	4460	3550	3550
MRS55L MRS55LW MRT55LW	155000	249000	5800	6000	6000

PRELOAD / RADIAL CLEARANCE

In the table below classes of preload and radial clearance of the sliders are indicated.

Preload Grade	Class of Preload	Preload
Clearance	G1	0
No preload	K0	0
Light preload	K1	0.02 x (C)*
Medium preload	K2	0.05 x (C)*
Heavy preload	K3	0.07 x (C)*

* (C) is the dynamic load capacity indicated in the load capacity table above.

Size	Radial Clearance (µm)				
	G1	K0	K1	K2	K3
15	4 / 14	-4 / 4	-12 / -4	-20 / -12	-28 / -20
20	5 / 15	-5 / 5	-14 / -5	-23 / -14	-32 / -23
25	6 / 16	-6 / 6	-16 / -6	-26 / -16	-36 / -26
30	7 / 17	-7 / 7	-19 / -7	-31 / -19	-43 / -31
35	8 / 18	-8 / 8	-22 / -8	-35 / -22	-48 / -35
45	10 / 20	-10 / 10	-25 / -10	-40 / -25	-55 / -40
55	12 / 22	-12 / 12	-29 / -12	-46 / -29	-63 / -46



LINEAR PRECISION

Linear precision means the running parallelism of the slider, i.e. the maximum deviation of the slider, referred to the lateral surface and to the supporting one, during its run along the rail.

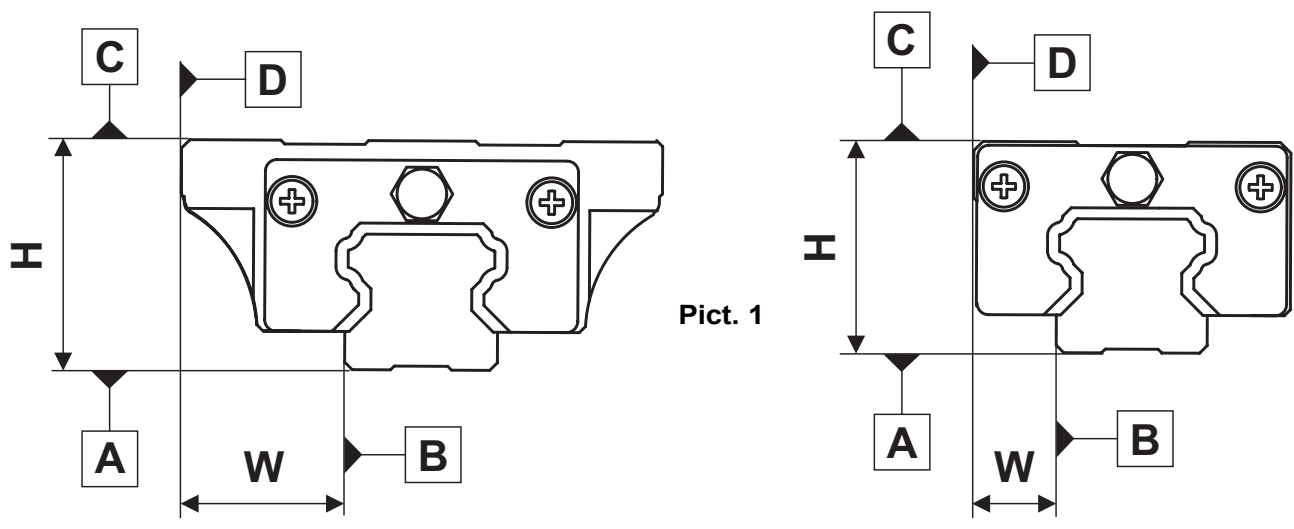

Pict. 1

	CLASS OF PRECISION (mm)				
	Normal (N)	High (H)	Precision (P)	Super-Precision (SP)	Ultra-Precision (UP)
Tolerance of height (H)	± 0.1	± 0.04	0 -0.04	0 -0.02	0 -0.01
Tolerance of width (W)	± 0.1	± 0.04	0 -0.04	0 -0.02	0 -0.01
Difference of heights (ΔH)	0.03	0.02	0.01	0.005	0.003
Difference of widths (ΔW)	0.03	0.02	0.01	0.005	0.003
Running parallelism of slider surface C as to surface A	ΔC refer to Pict. 1				
Running parallelism of slider surface D as to surface B	ΔD refer to Pict. 1				

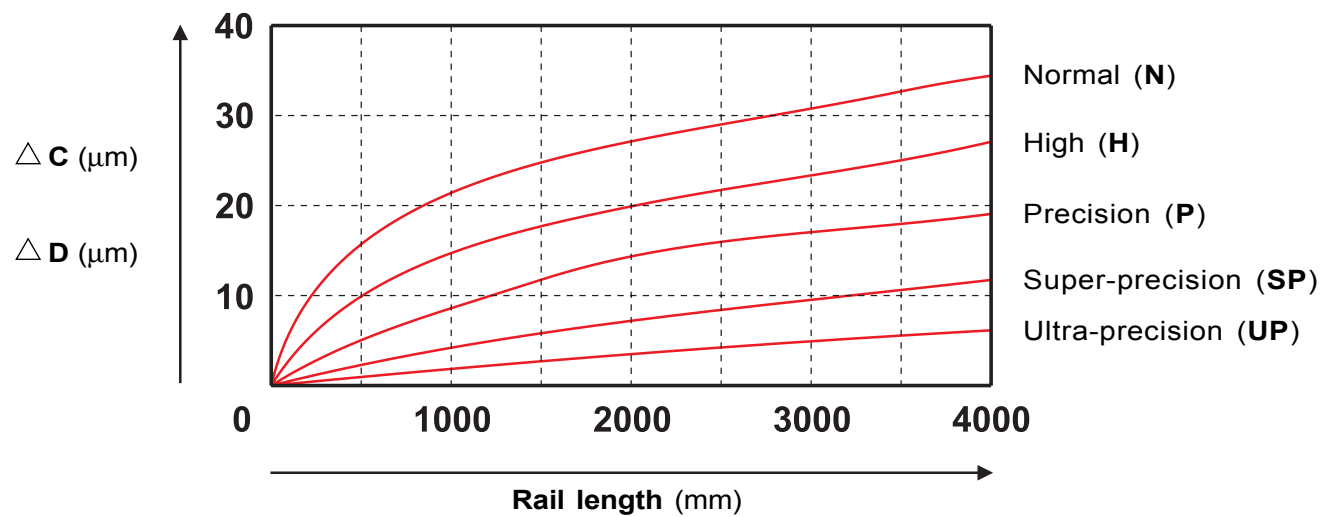

LIFETIME

LIFE CALCULATION:

The dynamic load rating **C** is a conventional load rating used in life calculations. The life to which this load rating is here related is 50 km. Life L_{km} (in km), load rating **C** (in Newton) and the applied external load **P** (in Newton) are related to each other by the formula:

$$L_{km} = \left(\frac{C}{P} \cdot \frac{f_c \cdot f_t \cdot f_h}{f_i} \right)^3 \cdot 50$$

where:

- fc** = contact factor
- ft** = temperature factor
- fh** = hardness factor
- fi** = service factor

Contact factor f_c

The factor f_c refers to applications where more than one slider pass over the same point on the rail. In ball recirculating systems is difficult to obtain a uniform load distribution because of the mounting surfaces precision. When two or more sliders are acting over the same points of the rail, we need to multiply static and dynamic load rating by the figures in the table below:

No. of sliders per rail	1	2	3	4	5
f_c	1	0.81	0.72	0.66	0.61

Temperature factor f_t

When the system temperature is higher than 100 °C, temperature factor f_t has a significant value (lower than 1).

Note 1: above 80°C, seals and end plates should be designed for high temperature operations.

Note 2: above 120°C, special treatments should be designed for stabilizing the dimensions.

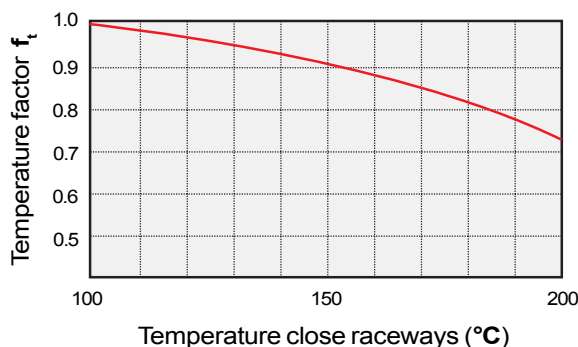

Hardness factor f_h

The optimum load capacity can be reached when the raceways hardness is 58 to 64 HRC.

If the raceways hardness is lower than 58 HRC, the load rating **C** must be multiplied by hardness factor f_h indicated in the table nearby.

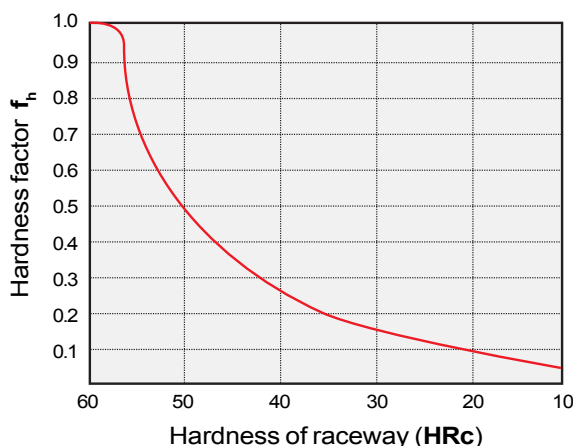

Service factor f_i

Service factor f_i has a meaning similar to the safety factor used in the 'Verification under static load' and the values are indicated in the table below:

OPERATING CONDITION	SPEED	f_i
Without external impacts or vibrations	At low speed $V <= 15$ m/min.	1 – 1.5
Without significant impacts or vibrations	At medium speed $15 < V <= 60$ m/min.	1.5 – 2
With external impacts or vibrations	At high speed $V > 60$ m/min.	2 – 3.5

VERIFICATION UNDER STATIC LOAD

CALCULATION:

The values of static load rating given on page 10 for each slider, represent the maximum allowable loads, above which a permanent deformation of the raceways could occur and consequently the running quality could be compromised.

The verification is made:

- by calculating the forces and the moments acting simultaneously on each slider
- by comparing these values with the corresponding load ratings

If:

P_r , P_a are the radial and axial resultants of the external forces, in Newton;

M_1 , M_2 , M_3 are the external moments, in Nm;

C_0 , M_x , M_y , M_z are the load ratings in the various directions, given on page 10;

f_s is the safety factor (see table below);

f_c is the contact factor (see table on page 12);

the result should be:

$$\frac{P_r}{(f_c \cdot C_0)} < \frac{1}{f_s} \quad \frac{P_a}{(f_c \cdot C_0)} < \frac{1}{f_s} \quad \frac{M_1}{(f_c \cdot M_x)} < \frac{1}{f_s} \quad \frac{M_2}{(f_c \cdot M_y)} < \frac{1}{f_s} \quad \frac{M_3}{(f_c \cdot M_z)} < \frac{1}{f_s}$$

Values of the safety factor f_s :

OPERATING CONDITION	LOAD CONDITION	f_s
Normally Stationary	Small impacts and deflection	1 – 1.3
	Impacts or twisting loads are applied	2 – 3
Normally Moving	Small impacts or twisting loads are applied	1 – 1.5
	Impacts or twisting loads are applied	2.5 – 5

The safety factor f_s should be lowest when the dynamic forces to be added to the loads can be determined accurately, and higher when overloads may occur, especially dynamic loads such as shocks and vibrations.

Please contact our Application Engineering Department if further information is required.

MOUNTING METHODS

In the tables below are indicated the types of screw to be used and the optimum tightening torques for rails mounting.

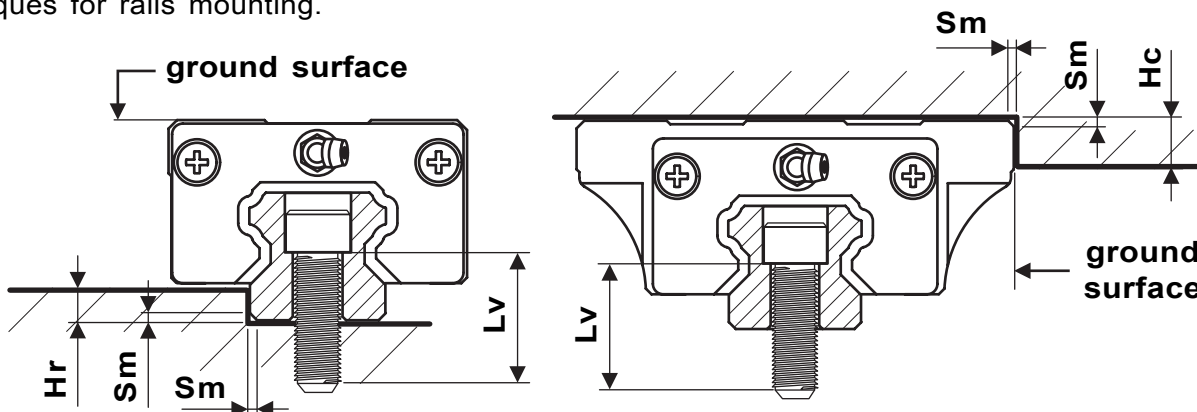

size	maximum chamfer Sm (mm)	maximum height rail shoulder Hr (mm)	maximum height slider shoulder Hc (mm)	fixing screw length (rail) Lv (mm)	Screw	Tightening Torque (Nm)
15	0.8	4	5	M4 x 16	M4	2,5
20	0.8	4.5	6	M5 x 20	M5	5,2
25	1.2	6	7	M6 x 25	M6	8,8
30	1.2	8	8	M8 x 30	M8	22
35	1.2	8.5	9	M8 x 30	M10	44
45	1.6	12	11	M12 x 40	M12	77
55	1.6	13	12	M14 x 45	M14	124
					M16	200

MOUNTING PRECISION

In the drawing and table below the maximum allowable errors of the rails mounting surfaces are indicated.

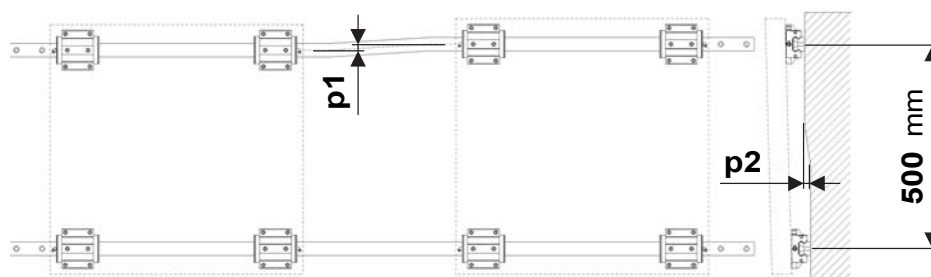

size	Permissible Tolerances for Parallelism p1 (μm)					Permissible Tolerances of Level Offset p2 (μm)				
	K3	K2	K1	K0	G1	K3	K2	K1	K0	G1
15			18	25	35			85	130	190
20		18	20	25	35		50	85	130	190
25	15	20	22	30	42	60	70	85	130	195
30	20	27	30	40	55	80	90	110	170	250
35	22	30	35	50	68	100	120	150	210	290
45	25	35	40	60	85	110	140	170	250	350
55	30	45	50	70	95	125	170	210	300	420

MOUNTING PROCEDURE

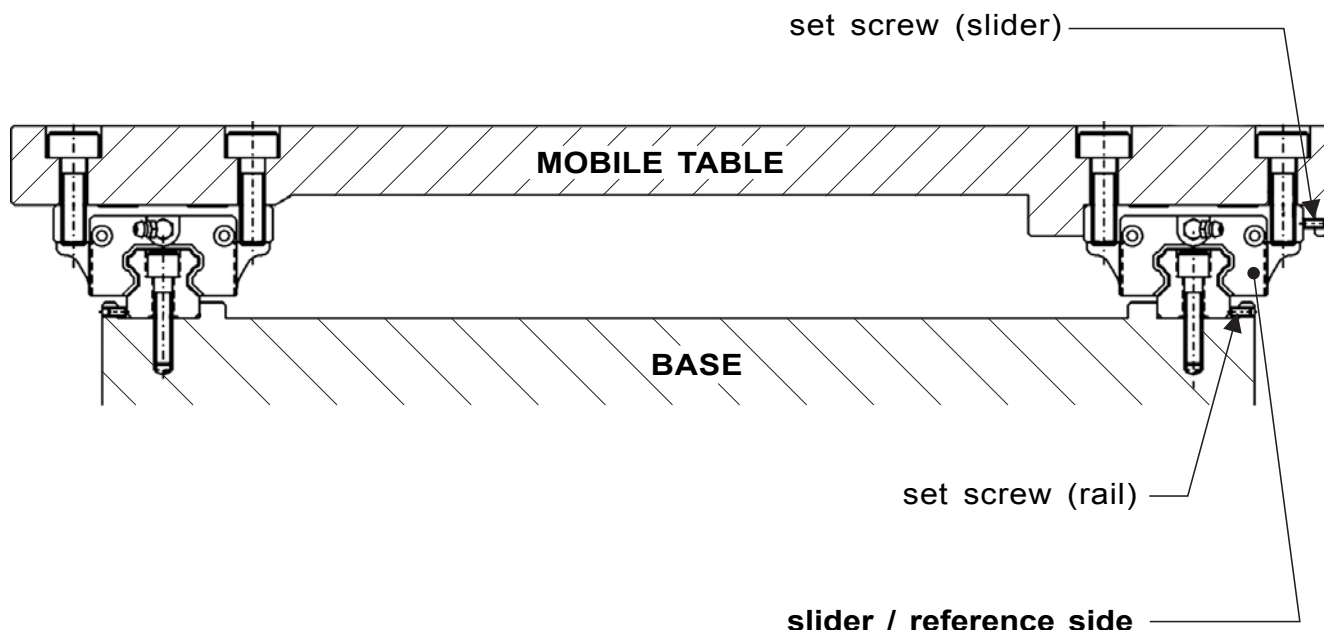

INSTRUCTIONS:

1. Remove dents, burrs and dirt on mounting surfaces;
2. Place rail against the shoulder of mounting surfaces;
3. Tighten the mounting bolts lightly (check that holes on rail are aligned with the screw holes on mounting surfaces). Do not tighten a bolt if the holes are not aligned;
4. Tighten the rail set screws;
5. When tightening the mounting bolts, start with the bolt at the longitudinal center of the rail and move towards both rail ends;
6. Mount the other rail in the same way (from point 1. to 5.);
7. Install caps in unused mounting holes;
8. Place the table on the blocks carefully, checking the screw holes alignment;
9. Tightening the block set screw to position the table;
10. Tighten the mounting bolts on the master and subsidiary blocks (the mounting bolts should be tightened in the diagonal sequence);

Note: Accuracy of master rail depend on the accuracy of shoulder and datum plane of frame.

FIXING EXAMPLES

In the drawings below some rail/slider fixing examples, following the structure type to which they are joined, are indicated.

Example 1

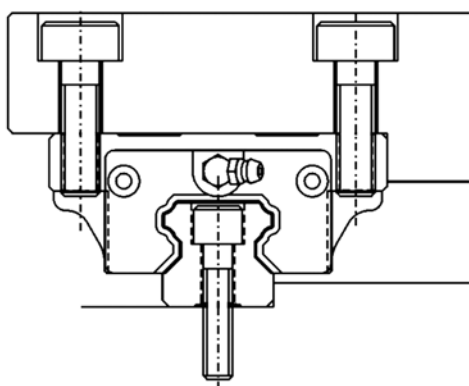

Example 2

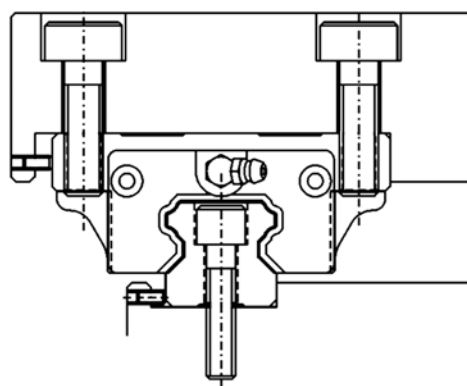

Example 3

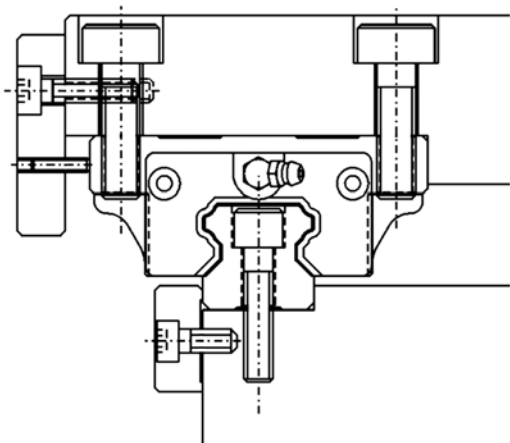

Example 4

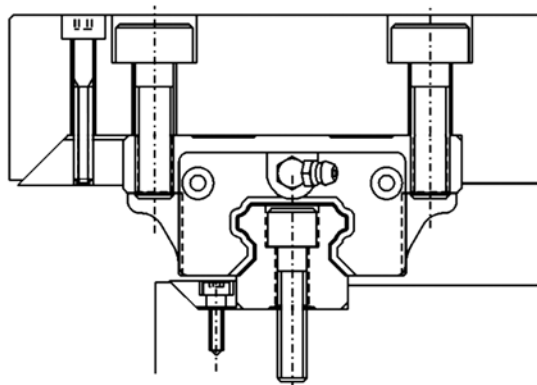

Example 5

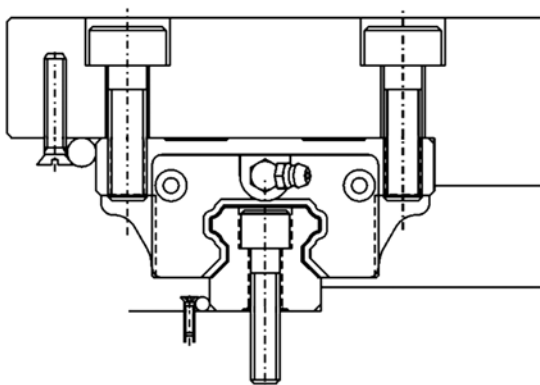

Example 6

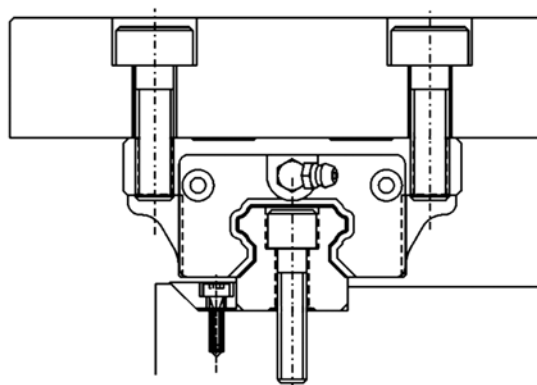



ORDER CODES

The rails and sliders order codes are listed below. Rails and sliders must be ordered separately.

Slider (with flange):

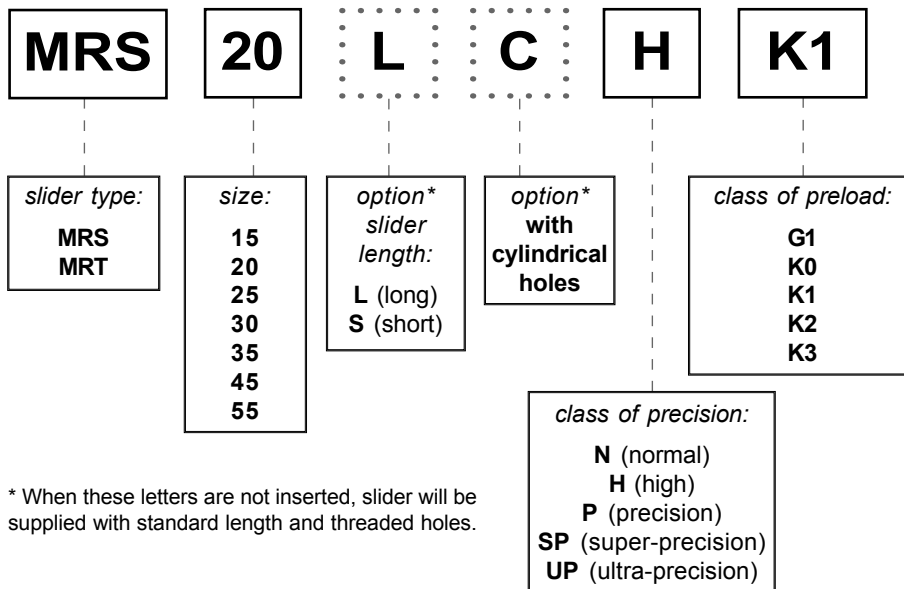

Slider (without flange):

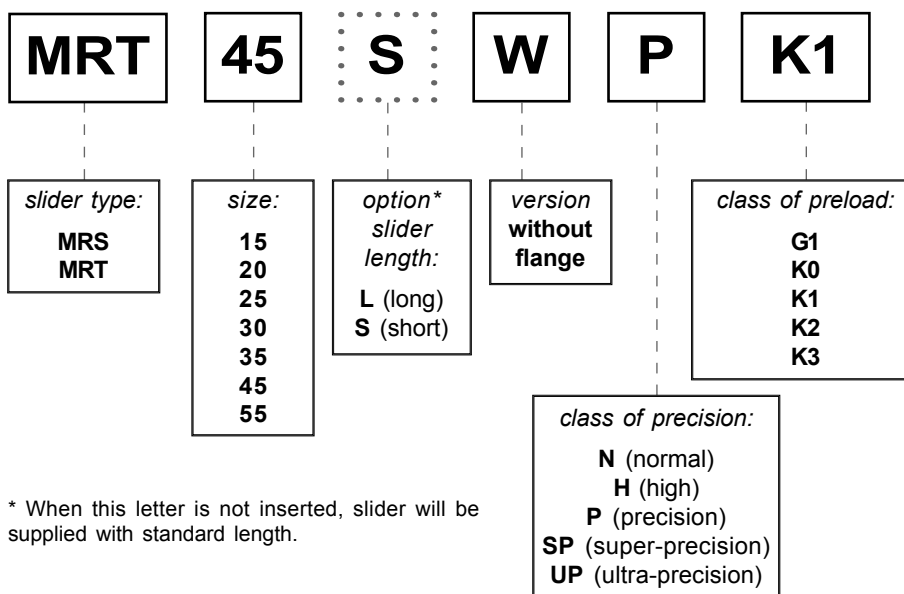

Rail:

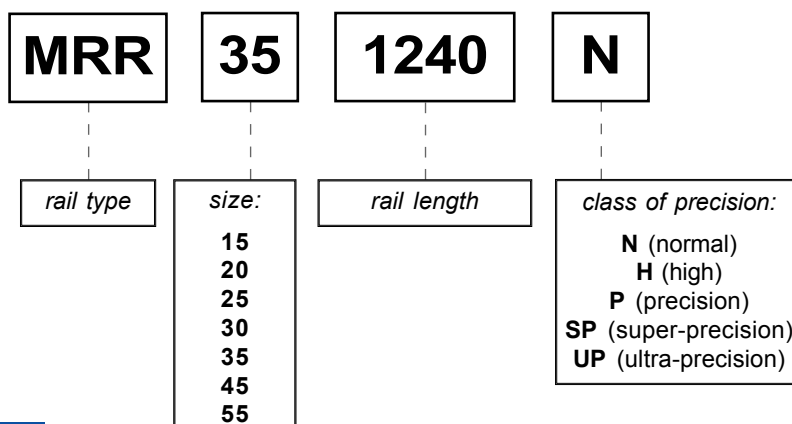

More product families:



COMPACT RAIL:

World's most versatile roller slider system

COMPACT RAIL has all of the characteristics that distinguishes **ROLLON's** whole product line: originality, innovative designs, compactness, smooth movement, and ease of use. The T+U and K+U rail systems can be mounted on non-machined surfaces and can even compensate for mounting surface parallelism inconsistencies. This flexibility allows the design engineer to focus more time and energy on the application itself and not on the components while saving large amounts of mounting time and, therefore, money. All **COMPACT RAIL** sliders have radial ball bearing rollers, which provide smooth and fast movement.



UNILINE:

Linear units with roller sliders

A complete family of belt-driven linear actuators designed to run in real-world applications. Based on **COMPACT RAIL**, these compact units are versatile, fast, and well protected. With designs for every application, **UNILINE** offers "personalized" actuators with high load capacity, high stiffness and rigidity, and all in a very compact, high quality package. With tee-slots and standard accessories, this family is as modular and versatile as it is innovative.



TELESCOPIC RAIL:

Industrial telescopic rails

ROLLON's **TELESCOPIC RAIL** family improves upon all of the characteristics that made our Heavy Duty family of rails well known. Design improvements on existing products and the addition of new ones will allow **ROLLON's** extended family of telescopic rails to remain the industry leader.

The **TELESCOPIC RAIL** family offers various types of slides which means that a design engineer can easily find an original solution for each application. All of the products have innovative, problem-solving designs and are built to extend heavy loads out from their mounting structure with little or no deflection.



EASY RAIL:

Strong and easy linear solution

The simple but extremely versatile design of the rails in this family is the characteristic that defines their success. Made from cold-drawn steel with internal, hardened raceways like most of **ROLLON's** products, these slides are made for 24 hours a day industrial use. With high load and moment capacities, **EASY RAIL** linear bearings are known for their high quality, affordability, ease of movement, and compactness.



ECOLINE:

Affordable and innovative linear bearings

ECOLINE's products have been designed to fit in applications where quality movement is needed but high prices are not. The patented design offers a wellprotected, smooth slide that is easily and quickly mounted. **ECOLINE** combines the quality associated with all of **ROLLON's** products with the affordability needed in application sectors like industrial protective panels, vehicle slides, and machine tool doors. **ECOLINE** is the answer to labor intensive, homemade solutions, cheap bent steel slides, or expensive, oversized round or profiled shafting.



CURVILINE:

High flexibility curvilinear rails

ROLLON's **CURVILINE** is the cost effective linear solution for applications with linear movement that isn't always strictly linear.

CURVILINE is a custom solution made according to your application's needs.

The system is composed of one or more sliders and a zinc-plated rail. The sliders have multiple radial ball bearings mounted to them providing the movement and carrying the load.

Two versions are available: one with a constant radius, and one with a variable radius which can be composed of both straight and curved sections. Each version has its own specific slider which is designed to uniformly follow the rail without modification to its preload. All sliders are have radial ball bearings which are lubricated for life and offer long life due to their hardened raceways.

...where you can find MONO RAIL:

www.rollon.com

Headquarters:

ROLLON S.p.A.

Via Trieste, 26 - 20059 Vimercate (MILANO) - ITALY

Phone: (+39) 039 62591 - Fax: (+39) 039 6259205

e-mail: infocom.it@rollon.com

Sales companies and Partners:

ROLLON GmbH

Industriegebiet Voisweg
40878 Ratingen - Germany
phone: (+49) 2102 8745 0
fax: (+49) 2102 8745 10
e-mail: info@rollon.de

ROLLON B.V.

Edisonstraat 32b
NL-6902 PK Zevenaar - Holland
phone: (+31) 316 58 19 99
fax: (+31) 316 34 12 36
e-mail: info@rollon.nl

ROLLON S.R.O.

Na Máčovně 1270
CZ-26604 Beroun - Czech Rep.
phone: (+420) 311 61 00 50
fax: (+420) 311 61 00 53
e-mail: info@rollon.cz

ROLLON S.A.R.L.

8, rue Paul Valérien Perrin
Z.I. de la Tuilerie
38170 Seyssinet - France
phone: (+33) 04 38 12 05 22
fax: (+33) 04 38 12 16 33
e-mail: infocom@rollon.fr

HAUDENSCHILD AG

Hummelbergstrasse 11
Postfach 1529
CH-8640 Rapperswil-Jona - Switzerland
phone: (+41) 055 225 40 50
fax: (+41) 055 225 40 60
e-mail: haud@haudenschild.com

S.R.O ASSI SA

Centro GTL, CP47
CH-6929 Gravesano - Switzerland
phone: (+41) 91 612 22 80
fax: (+41) 91 612 22 89
e-mail: sro.assi.sa@bluevin.ch