

SKF Wireless Machine Condition Sensor

CMWA 8800

Introduction

The SKF Wireless Machine Condition Sensor combines a sensor, data collector and radio into one compact, battery-operated device that measures both vibration and temperature data. This unique system, which is approved for use in extremely hazardous areas requiring ATEX Zone 0 certification, provides an ideal balance-of-plant monitor, wirelessly transmitting both static and dynamic data to the SKF @plitude Monitoring Suite software.

The SKF Wireless Machine Condition Sensor uses the *WirelessHART* communication protocol, offering a simple, reliable and secure means of expanding condition based maintenance into plant areas where the cost to install wired systems is prohibitive, making data available to existing process control and information systems. To overcome wireless communication obstacles, sensors can be configured to operate as router nodes, allowing them to relay data from other sensors.

Benefits

- Compact sensor with small physical footprint
- Reduced installation costs – no wires or cables!
- Certified for hazardous areas
- Quick and scalable deployment
- Cost effectively monitor large plant areas



Hardware features

- Certified to ATEX Zone 0
- Overall and dynamic vibration data
- Velocity measurements for detecting faults such as imbalance, misalignment, and looseness
- SKF Acceleration Enveloping for detecting bearing and other impact type faults
- Temperature
- Periodic measurements
- Up to 5 year battery life
- Low power consumption radio operating on *WirelessHART* protocol



Applications

The low deployment costs make this wireless solution ideal for:

Expanding walk-around routes

Collect data automatically and more frequently from plant areas where it is uneconomical, impractical, or unsafe to retrieve data manually.

Troubleshooting

Temporarily install the sensor on suspect equipment to more closely track failing components.

Difficult to reach areas

Collect basic vibration data in locations that are difficult to monitor with fixed wired systems or hand-held devices.

A complete system

The SKF Wireless Machine Condition Sensor is designed for use in a system consisting of the following components:

- SKF Wireless Machine Condition Sensors
- *WirelessHART* Gateway
- Wireless Sensor Device Manager software
- SKF @ptitude Analyst software

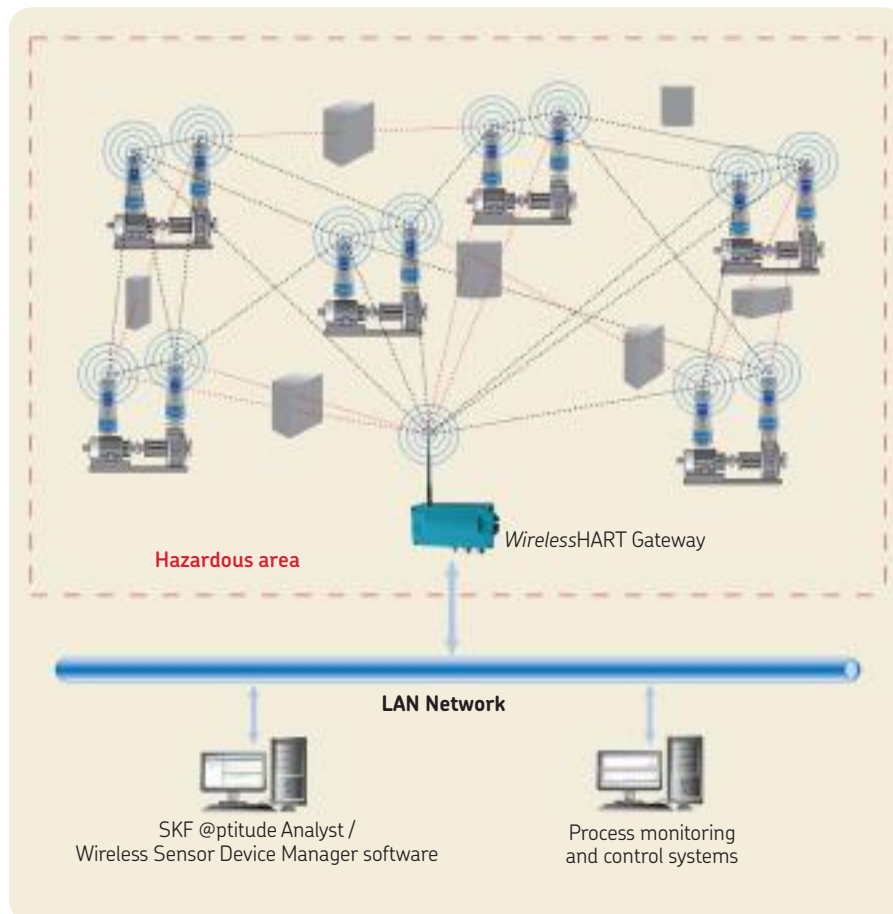

A robust and secure wireless system.

A robust and secure wireless system

The SKF Wireless Machine Condition Sensor is mounted to the bearing housing of machines in the same way as an accelerometer, typically using a stud-mount. A mesh network, which navigates around obstacles, is formed automatically with the sensors. The *WirelessHART* Gateway continuously analyzes and optimizes the network to implement the most efficient paths and balance load across alternative paths. For its entire life, the radio of the SKF Wireless Machine Condition Sensor remains on. This allows it to communicate with other *WirelessHART* field devices at all times. Key advantages of using the *WirelessHART* communication protocol are:

- **Reliability** – even in the presence of interference, thanks to mesh networking, channel hopping and time-synchronized messaging, *WirelessHART* provides 99.9% end-to-end reliability in challenging radio environments.

- **Security and Privacy** – network communications are secured through industry-standard practices of authentication, encryption and verification to ensure the highest level of security.
- **Effective power management** – making low power consumption and long battery life possible.

WirelessHART enables users to quickly and easily gain the benefits of wireless technology while maintaining compatibility with existing devices and tools. **An added benefit is that overall vibration and temperature data collected with the SKF Wireless Machine Condition Sensor is available to customer's existing process monitoring and control systems.**

Specifications

Data acquisition

- Single axis vibration overall levels, time waveforms of 2048 samples
 - Post processed FFTs of 800 lines to 1 144 Hz
- Temperature
- Data acquisition modes:
 - Polling (triggered over radio)
 - Bursting (programmable interval)

Measurements

- Temperature:
 - Range: -40 to $+85$ °C (-40 to $+185$ °F)
 - Accuracy: ± 2 °C (± 3.6 °F)
- Vibration:
 - Velocity:
 - Units: mm/s or inch/s
 - Frequency range: 10 Hz to 1 kHz
 - Amplitude range: 0.2 to 350 mm/s (0.008 to 13.8 inch/s)
 - Accuracy at 20° C (68 ° F): $\pm 10\%$ in passband, 3 dB corners 10 Hz and 1 kHz
 - Detection type: RMS
 - SKF Acceleration Enveloping Filter 3:
 - Units: m/s²(E) or gE
 - Input filter frequency range 500 Hz to 10 kHz
 - Amplitude range: 0.25 to 245 m/s²(E) (0.025 to 25 gE)
 - Detection type: Peak to Peak

Wireless Communications

- IEEE WirelessHART protocol
- IEEE 802.15.4 radio
- Firmware update via WirelessHART Network (OTAP)
- Range: 50 m (165 ft.) typically in plant (actual range depends on specific site topology and device placement)

Certifications

- Radio:
 - FCC: Part 15 Subpart C
 - IC: RSS-210 issue 8
 - ETSI:
 - EN 300 328 v.1.7.1
 - EN 301 489-1 v.1.9.2
 - EN 301 489-17 v.2.2.1

Hazardous area certification

- ATEX Zone 0
 -  II 1G
 - Ex ia IIC T4 -40 °C \leq Ta \leq 85 °C

Physical

- Dimensions : (→ Fig. 1)
- Weight: 190 g (6.7 oz.)
- Case material:
 - Base: Stainless steel
 - Cover: Thermoplastic
- Sealing: IP 66

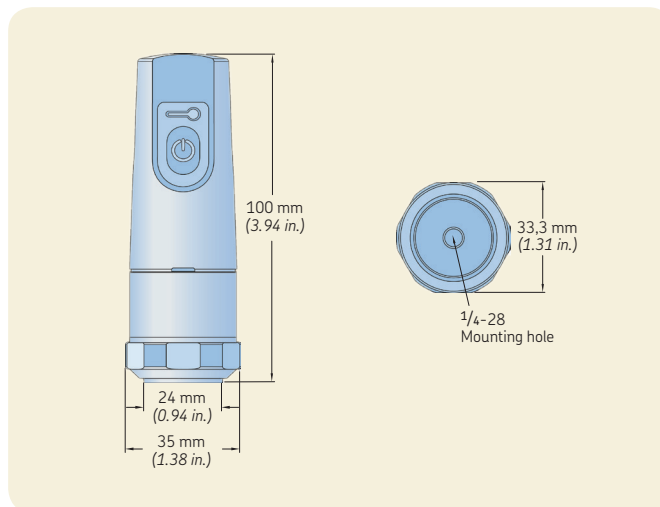

Fig. 1. SKF Wireless Machine Condition Sensor dimensions.

Environmental

- Operating temperature: -40 to $+85$ °C (-40 to $+185$ °F)
- Recommended storage temperature: $+30$ °C ($+86$ °F) maximum

Power

- Internal 3.6 V primary lithium-thionyl chloride (Li-SOCl₂) bobbin cell
- Up to 5 year battery life, depending on settings, usage and operating temperature.
- Estimated battery life at different operating temperatures, at default sensor configuration (see notes 1, 2, and 3):

Operating temperature	Battery life in years
-40 °C to -20 °C (-40 °F to -4 °F)	3
-20 °C to 0 °C (-4 °F to $+32$ °F)	4
0 °C to $+40$ °C ($+32$ °F to $+104$ °F)	5
$+40$ °C to $+70$ °C ($+104$ °F to $+158$ °F)	3

Note 1: Default sensor configuration is:

Temperature measurement collected every 5 minutes with all measurements uploaded once per hour. Vibration measurements (velocity and acceleration enveloping) collected every hour with static data (overall values) uploaded once per hour, and a single set of time waveforms uploaded once per day. Sensor operating as a leaf node (not routing).

Note 2: Continuous operation in the $+70$ °C to $+85$ °C ($+158$ °F to $+185$ °F) temperature range is not recommended as it will dramatically shorten battery life.

Note 3: Operating a sensor in routing mode will increase energy consumption and reduce its battery life, the extent of which depends on the number of child nodes and amount of data being routed.

Mounting considerations

The SKF Wireless Machine Condition Sensor is preferably stud mounted on the measurement location for best mechanical coupling and frequency response, alternatively can be adhesively or magnetically mounted. If stud mounted, use of a thread adhesive is recommended as well as the use of a coupling fluid between the mating surfaces as this optimizes frequency response by further increasing the stiffness of the coupling. When installed in a hazardous area, the sensor must be mounted in such a way that it is grounded to the machine, which can be achieved with either stud, adhesive or magnet mount. Contact your local SKF organization for advice on electrically conductive adhesives available in your local market.

- Required spanner size for sensor mounting: 33.3 mm (1.31 in.)
- Internal 1/4-28 UNF thread
 - Mounting studs provided: One (1) 1/4-28 to 1/4-28 UNF English thread and one (1) 1/4-28 UNF to M8 × 1.25 metric thread
 - Mounting torque: 2,9 N-m (24 in-lbs.)

Optional accessories for adhesive mounting

Instead of adhesively mounting the SKF Wireless Machine Condition Sensor directly onto the machine, you can use mounting pads. The mounting pads are adhesively mounted onto the machine and the SKF Wireless Machine Condition Sensor is torqued with a mounting stud onto the mounting pad, thereby allowing for easy replacement.

No Surprises

For early detection of abnormal machine conditions, and analysis of detected problems, SKF @ptitude Monitoring Suite software provides fast, efficient and reliable storage, analysis and reporting on overall and dynamic machine vibration data (FFT and time waveform) collected with the SKF Wireless Machine Condition Sensor. A wide range of customizable reports can be automatically scheduled, making your machine data accessible throughout your organization. Overall machine data can also be integrated into existing plant control systems and asset monitors.



SKF @ptitude Analyst trend / spectrum plot.

Wireless Sensor Device Manager software

The WirelessHART Gateway communicates with the Wireless Sensor Device Manager software supplied by SKF. This software is used to manage sensor status information, set burst intervals for vibration

overall levels and temperature measurements, collect overall and dynamic data and relay information to SKF @plitude Analyst. The Wireless Sensor Device Manager software also processes user requests for “live” data.

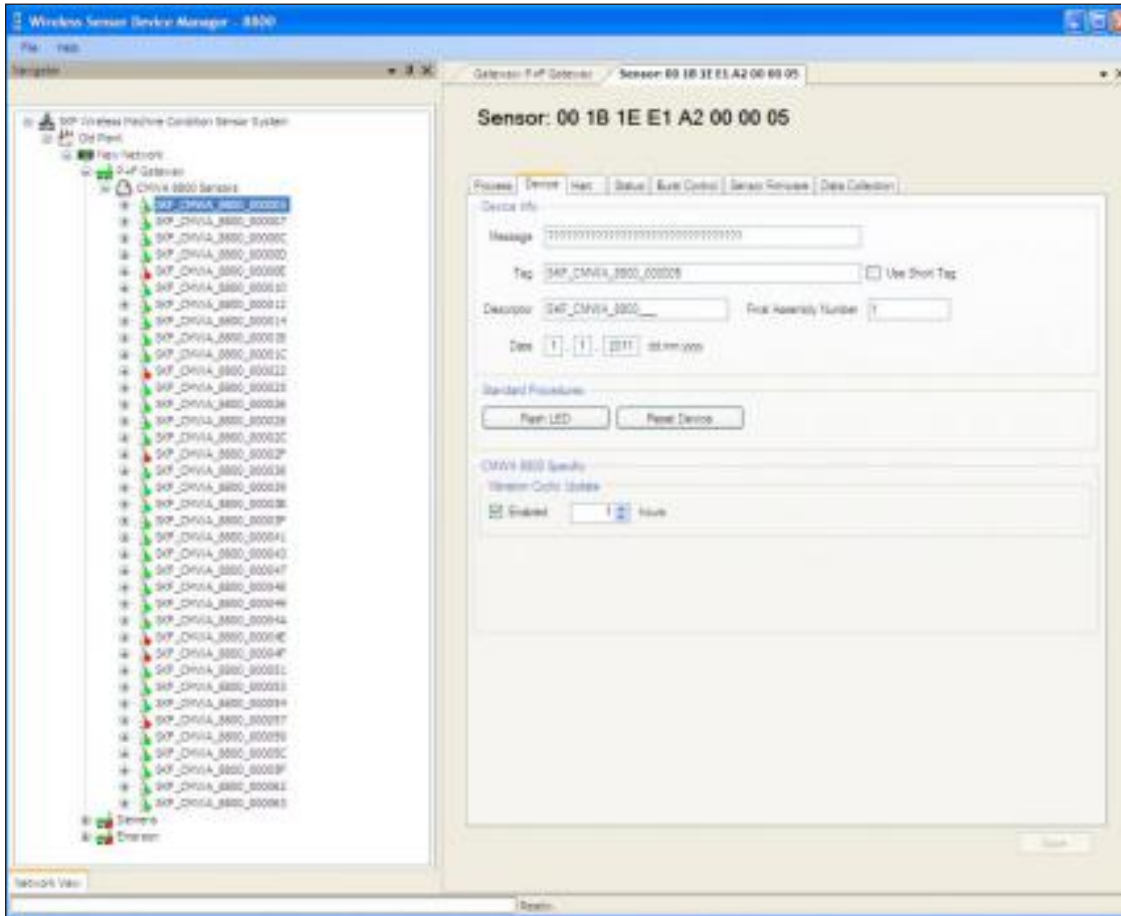

Wireless Sensor Device Manager software plot.

Ordering Information

Sensor

- SKF Wireless Machine Condition Sensor, ATEX Zone 0 (II 1G, Ex ia IIC T4 $-40\text{ °C} \leq T_a \leq 85\text{ °C}$) [**CMWA 8800**]
- SKF Wireless Machine Condition Sensor, ATEX Zone 0 (II 1G, Ex ia IIC T4 $-40\text{ °C} \leq T_a \leq 85\text{ °C}$), with pre-configuration services to set the network ID and join key plus other operational parameters [**CMWA 8800-C**]

Pepperl+Fuchs WirelessHART Gateway components

- Pepperl+Fuchs *WirelessHART* gateway, ATEX Zone 2 (II 3G Ex nA II T4), painted aluminum enclosure with stainless steel cable glands [**CMWA 8850-PF-SS**]
- Power supply for the Pepperl+Fuchs *WirelessHART* Gateway; Phoenix Contact, 110/220 VAC input, +24 VDC output, Class I Division 2 certified [**CMMA 9170**]

Pepperl+Fuchs WirelessHART Gateway Kit

The Gateway Kit [**CMWA 8850-PF-SS-K**] includes:

- Pepperl+Fuchs *WirelessHART* Gateway, ATEX Zone 2 (II 3G Ex nA II T4), painted aluminum enclosure with stainless steel cable glands [**CMWA 8850-PF-SS**]
- Power supply for the Pepperl+Fuchs *WirelessHART* Gateway; Phoenix Contact, 110/220 VAC input, +24 VDC output, Class I Division 2 certified [**CMMA 9170**]

Pepperl+Fuchs Router components

- Pepperl+Fuchs Router (Adapter) unit, Class I Division 1 and ATEX Zone 1 (II 2 G Ex ia IIC T4 Gb) certified, provides additional routing capabilities for networks [**CMWA 8860-PF-RT**]
- Mounting kit [**CMWA 8860-PF-MK**]
- Battery for CMWA 8860-PF-RT Pepperl+Fuchs Router unit [**CMWA 8860-PF-BT**]

Pepperl+Fuchs Router Kit

The Pepperl+Fuchs Router Kit [**CMWA 8860-PF-K**] includes:

- Pepperl+Fuchs Router (Adapter) unit, Class I Division 1 and ATEX Zone 1 (II 2 G Ex ia IIC T4 Gb) certified, provides additional routing capabilities for networks [**CMWA 8860-PF-RT**]
- Mounting kit [**CMWA 8860-PF-MK**]
- The battery [**CMWA 8860-PF-BT**] is not included and needs to be ordered separately

Wireless Sensor Device Manager software

- Base software license, required for each software instance [**CMSW 8810-B**]
- Software license for (additional) 1 sensor, may be purchased in multiples [**CMSW 8810-1**]
- Software license for (additional) 10 sensors, may be purchased in multiples [**CMSW 8810-10**]
- Software license for (additional) 100 sensors, may be purchased in multiples [**CMSW 8810-100**]

Starter Kit

The Starter Kit [**CMWA 8800-SK**] contains:

- Pepperl+Fuchs *WirelessHART* Gateway, ATEX Zone 2 (II 3G Ex nA II T4), aluminum enclosure with stainless steel cable glands [**CMWA 8850-PF-SS**]
- Power supply for the Pepperl+Fuchs *WirelessHART* Gateway; Phoenix Contact, 110/220 VAC input, +24 VDC output, Class I Division 2 certified [**CMMA 9170**]
- Six (6) SKF Wireless Machine Condition Sensors [**CMWA 8800**]
- Mounting studs (two studs per sensor)
 - 1/4-28 to 1/4-28
 - 1/4-28 to M8 (adapter)
- CD with:
 - CMSW 8810 Wireless Sensor Device Manager software
 - CMSW 8810-B (Base software license)
 - CMSW 8810-10 (Software license for 10 sensors)
 - Setup Guide, User Manuals and Certifications

***Not included: SKF @ptitude Analyst software**

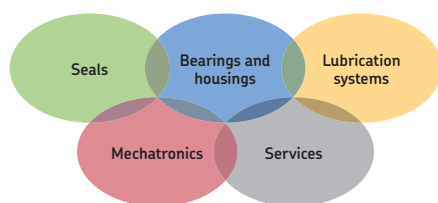

The Power of Knowledge Engineering

Combining products, people, and application-specific knowledge, SKF delivers innovative solutions to equipment manufacturers and production facilities in every major industry worldwide. Having expertise in multiple competence areas supports SKF Life Cycle Management, a proven approach to improving equipment reliability, optimizing operational and energy efficiency and reducing total cost of ownership.

These competence areas include bearings and units, seals, lubrication systems, mechatronics, and a wide range of services, from 3-D computer modelling to cloud-based condition monitoring and asset management services.

SKF's global footprint provides SKF customers with uniform quality standards and worldwide product availability. Our local presence provides direct access to the experience, knowledge and ingenuity of SKF people.

Please contact:

SKF USA Inc.

Condition Monitoring Center – San Diego

5271 Viewridge Court · San Diego, California 92123 USA

Tel: +1 858-496-3400 · Fax: +1 858-496-3531

Web: www.skf.com/cm

© SKF and @PTITUDE are registered trademarks of the SKF Group.

Pepperl+Fuchs is a registered trademark of Pepperl+Fuchs, Inc.

HART and *Wireless*HART are trademarks of the HART Communication Foundation.

All other trademarks are the property of their respective owners.

© SKF Group 2014

The contents of this publication are the copyright of the publisher and may not be reproduced (even extracts) unless prior written permission is granted. Every care has been taken to ensure the accuracy of the information contained in this publication but no liability can be accepted for any loss or damage whether direct, indirect or consequential arising out of the use of the information contained herein. SKF reserves the right to alter any part of this publication without prior notice.

Patents: US 4,768,380 · US 5,633,811 · US 5,679,900 · US 5,845,230 · US 5,852,351 · US 5,854,553 · US 5,854,994 · US 5,870,699 · US 5,907,491 · US 5,992,237 · US 6,006,164 · US 6,124,692 · US 6,138,078 · US 6,199,422 · US 6,202,491 · US 6,275,781 · US 6,301,514 · US 6,437,692 · US 6,489,884 · US 6,513,386 · US 6,633,822 · US 6,789,025 · US 6,792,360 · US 7,103,511 · US 7,697,492 · WO/2003/048714

PUB CM/P8 10243/3 EN · May 2014

