

19" Racks Types ABE 040 & ABE 042

FEATURES

- 19" rack
- Standard rack height of 6U
- Robust aluminium construction
- Modular concept allowing specific cards to be added for protection and condition monitoring
- Cubicle or panel mounting
- Backplane supporting VME bus as well as raw signal bus, tacho bus and open collector relay bus

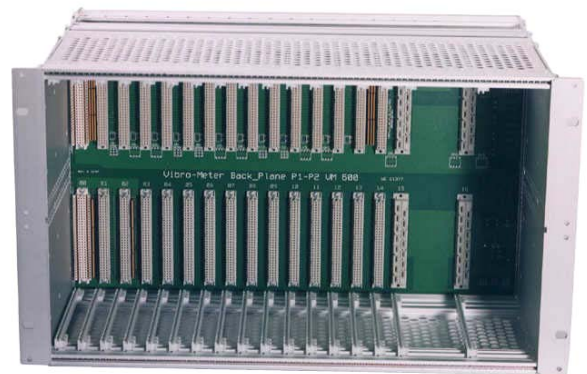

DESCRIPTION

These racks are used to house Vibro-Meter's VM 600 series of Machinery Protection and Monitoring Systems. Two rack types are presently available : the ABE 040 and the ABE 042. These are very similar, differing only in the position of the mounting brackets.

Both racks are particularly suitable for industrial environments, where equipment must be permanently installed in 19" cubicles or panels. Each rack has a standard height of 6U.

Each rack provides mounting space for up to 15 single-width VM 600 series cards, or a combination of single and multiple-width units.

The rack has a built-in VME backplane which assures the electrical interconnection between power supply units, signal processing cards, acquisition cards, CPU cards, input/output cards and relay cards.

The rack may be powered by a single RPS 6U power supply unit. Optionally, a second power supply may be installed to provide redundancy. Various versions of the RPS 6U exist, enabling the rack to be powered from an AC or DC supply and allowing various supply voltages to be used.

The rear of the rack gives access to the IOC input/output cards. These contain screw terminal strips or connectors for the connection of transducers / conditioners and for the input and output of various signals to an external control system.

Racks are generally already configured in the factory before delivery. The user therefore receives a ready-to-use system. Optionally, each card can be programmed at the site using the MPS1 or MPS2 software package (running on Windows).

Any rack position not used by a plug-in card can be covered by a blank panel.

MECHANICAL DRAWINGS (FRONT & REAR VIEWS)

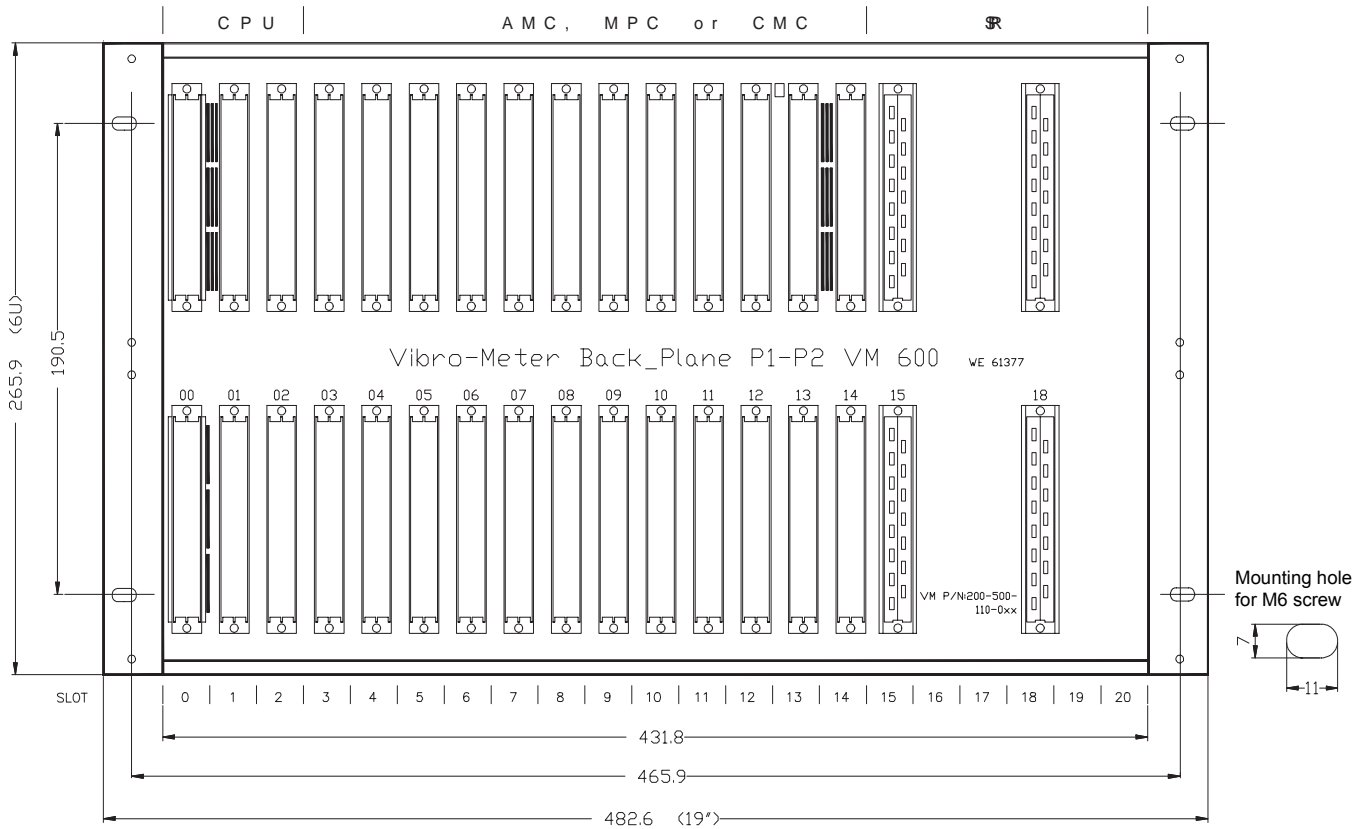

Fig. 1 : Front view of ABE 040 and ABE 042

(a) With AC Power Supply

(b) With DC Power Supply

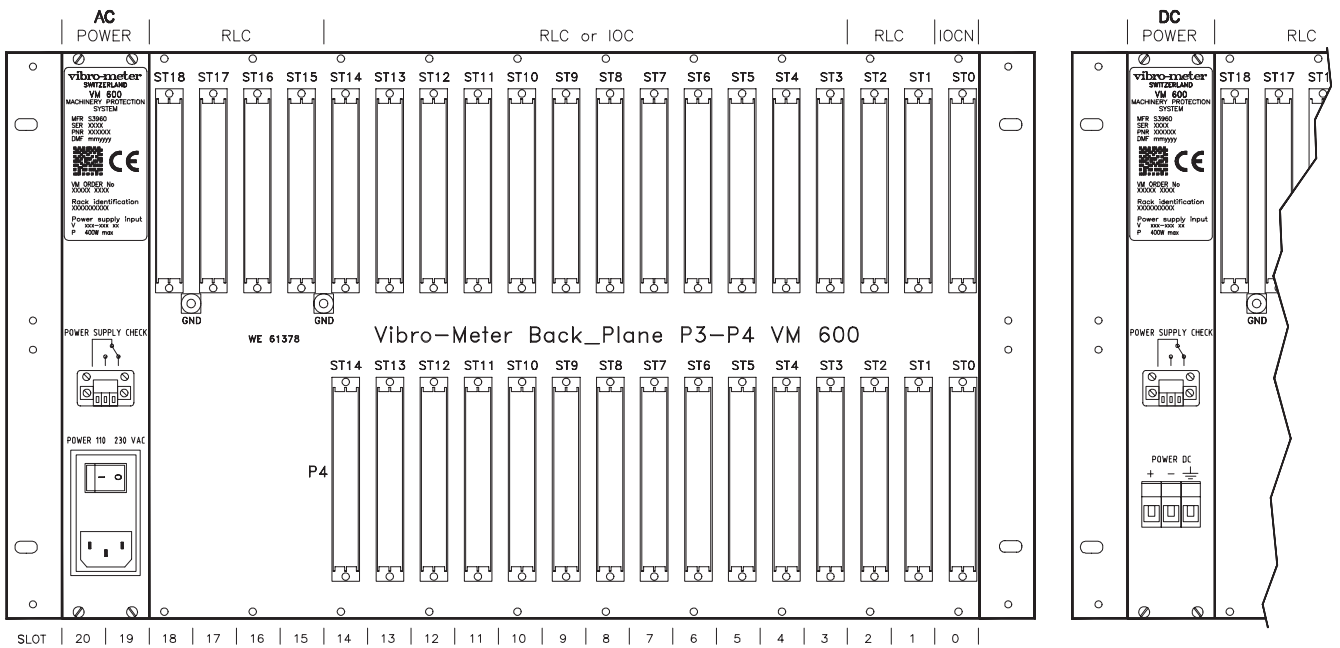

Fig. 2 : Rear view of ABE 040 and ABE 042

MECHANICAL DRAWINGS (SIDE & TOP VIEWS)

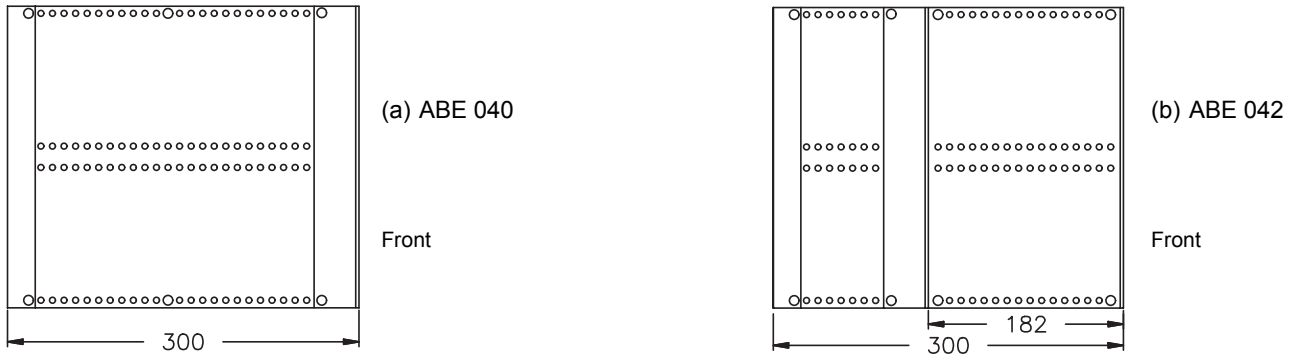

Fig. 3 : Side view of ABE 040 and ABE 042

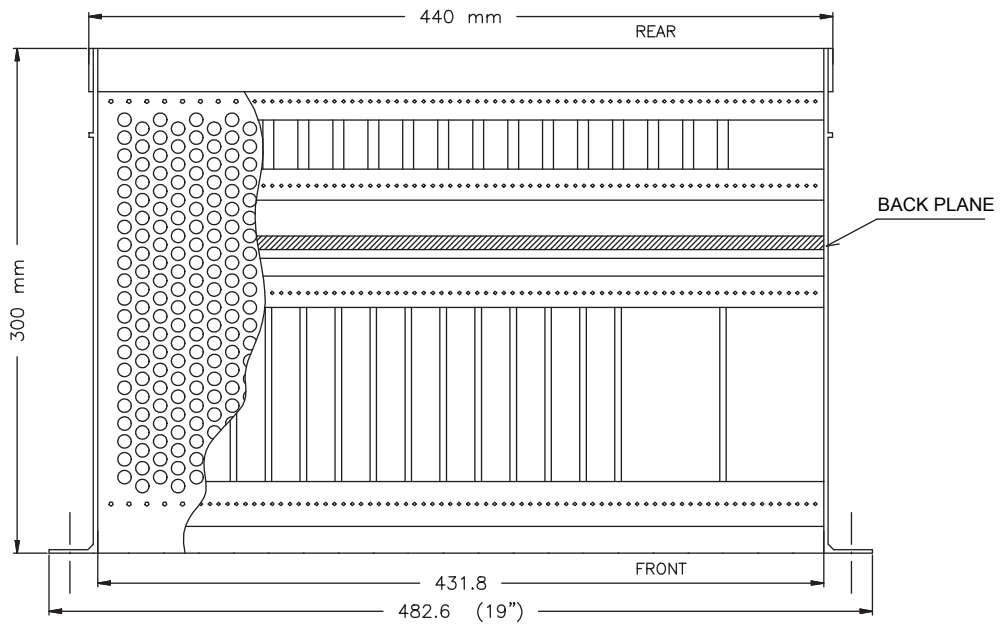

Fig. 4 : Top view of ABE 040

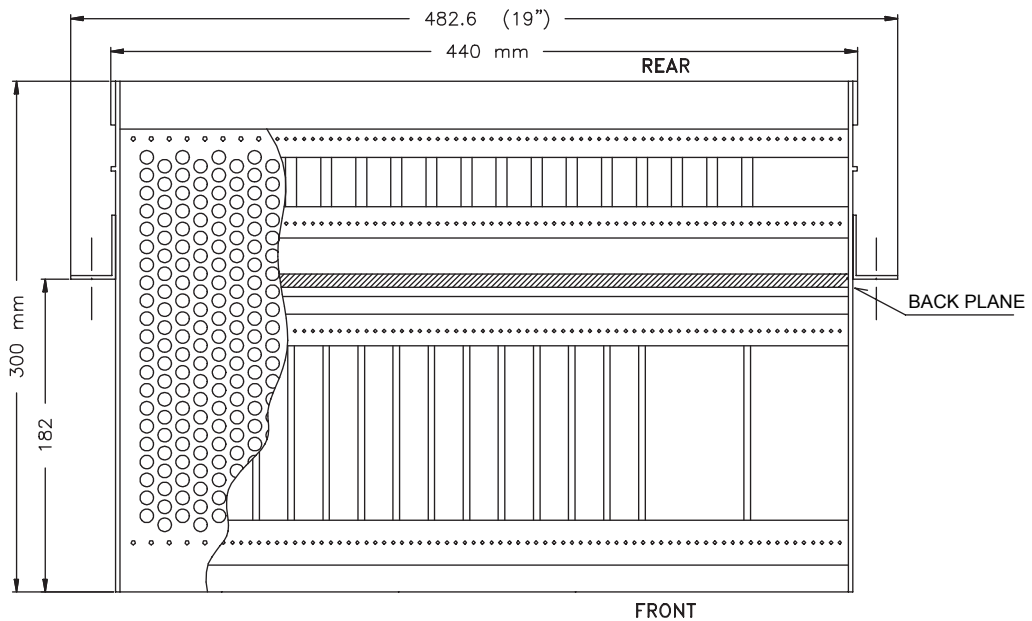

Fig. 5 : Top view of ABE 042

SPECIFICATIONS

Construction	: Extruded aluminium frame and solid aluminium structural parts. Top and bottom plastic guide strips for the plug-in cards.
Rack weight	: 6.5 kg (without power supply units and cards).
Mains input	: Racks are shipped with an RPS 6U power supply unit (2 units for systems with a redundant power supply). This unit has an AC or DC mains socket, mains cable of length 3 m and an RFI filter, if applicable.
Power supply	: RPS 6U series (+5 V / ±12 V DC) to supply electronic processing cards, input/output cards and relay cards.
Backplane	: Uses VME bus and dedicated bus for communication between cards. Unused slot positions must be covered with blank panels.
Galvanic separation	: Galvanic separation units (GSI types), if required for accelerometer and proximity systems mounted in explosive atmospheres. These units cannot be supplied by the rack and require an external power supply. They must be mounted outside the rack in a remote housing or in a cubicle.

ENVIRONMENTAL

According to IEC 68.2 recommendations

Temperature

- *Operation* : -25°C to +65°C
- *Storage* : -40°C to +85°C

Humidity : Max. 95% non-condensing

Vibration : 10 Hz to 55 Hz, 0.35 mm peak, 6 hours in each direction.

Shock : 15 g peak, 11 ms, half-sine pulse.

ORDERING INFORMATION

To order please specify the type, designation and ordering number :

Type and Designation		Ordering Number
ABE 040	Standard 19" rack, height 6U, including backplane	204-040-100-012
	19" rack, height 6U, including backplane, Separate circuits in accordance with IEC/CEI 60255-5 standard	204-040-100-111
ABE 042	19" rack, height 6U, including backplane	204-042-100-012
	Blank panel for rear of rack, 1 slot wide	200-505-001-011
	Blank panel for rear of rack, 2 slots wide	200-505-002-011
	Blank panel for rear of rack, 4 slots wide	200-505-003-011
	Blank panel for front of rack, 1 slot wide	200-505-005-011
	Blank panel for front of rack, 2 slots wide	200-505-006-011
	Blank panel for front of rack, 4 slots wide	200-505-007-011
	RPS 6U rack power supply units	See data sheet



In this publication, a dot (.) is used as the decimal separator and thousands are separated by spaces. Example : 12 345.678 90
 Although care has been taken to assure the accuracy of the data presented in this publication, we do not assume liability for errors or omissions.
 We reserve the right to alter any part of this publication without prior notice.

Head Office

Your Local Agent

Sales Offices

Vibro-Meter SA
 Rte de Moncor 4, P.O. Box,
 CH-1701 Fribourg, Switzerland
 Phone : +41 26 407 11 11
 Fax : +41 26 407 13 01
www.vibro-meter.com



Sales offices in :

- Germany
- USA
- Singapore
- Russia
- France
- Canada
- United Kingdom
- Ukraine

Agents in over 30 countries
 Vibro-Meter is a member of the
 Meggitt Aerospace Systems Division