

# Rothe Erde Großwälzlager.

Kranschiffe.

Schwimmkrane.

**Large Diameter  
Antifriction Bearings.**

Crane ships.

Floating cranes.

**Couronnes  
d'orientation.**

Grues flottantes.

Grues sur ponton flottant.

**Cuscinetti volventi  
di grande diametro.**

Gru per navi appoggio.

Gru galleggianti.

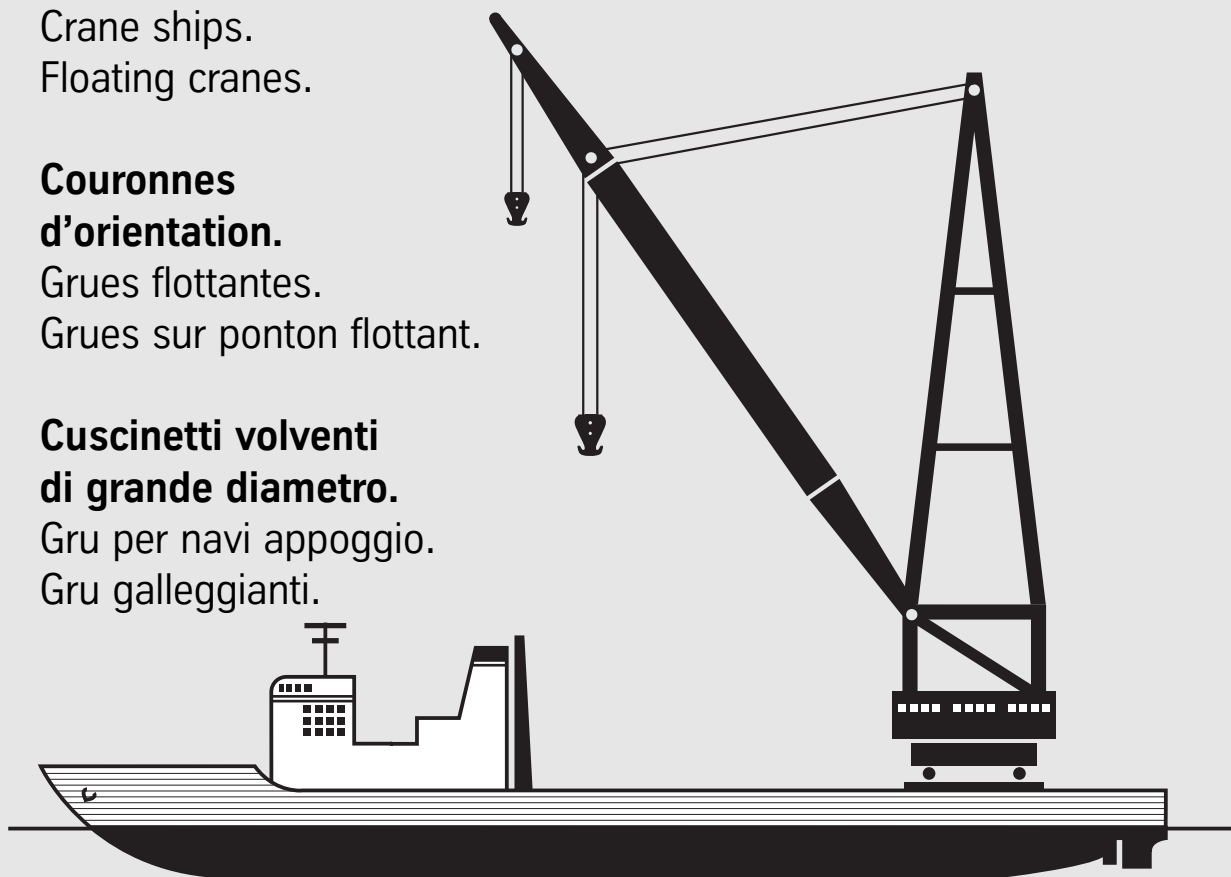

Anfrage-Daten.

Questionnaire.

Questionario. **KD 102**

**Betriebsbedingungen**  
**Operating conditions**  
**Conditions de service**  
**Condizioni di esercizio**

1. Kran in Betrieb  
ohne Krängung

Crane in operation  
without heel

Grue en service  
sans gîte

Gru in servizio  
senza sbandata

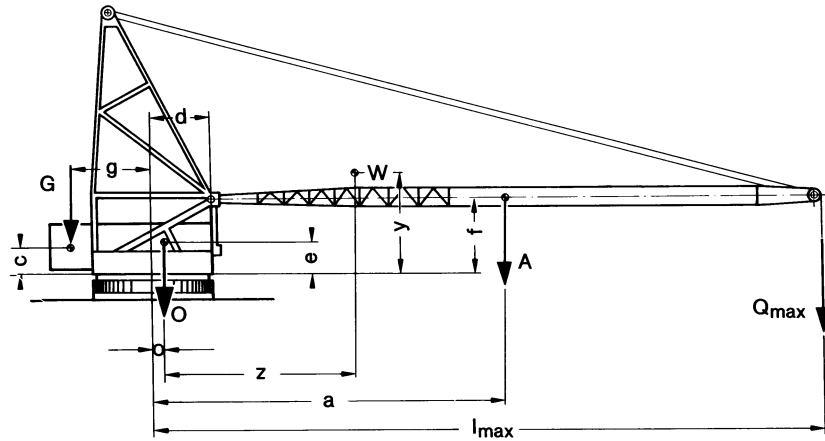

2. Kran in Betrieb  
bei maximaler Krängung  $\alpha$

Crane in operation  
at maximum heel  $\alpha$

Grue en service  
avec gîte maxi  $\alpha$

Gru in servizio  
con sbandata massima  $\alpha$

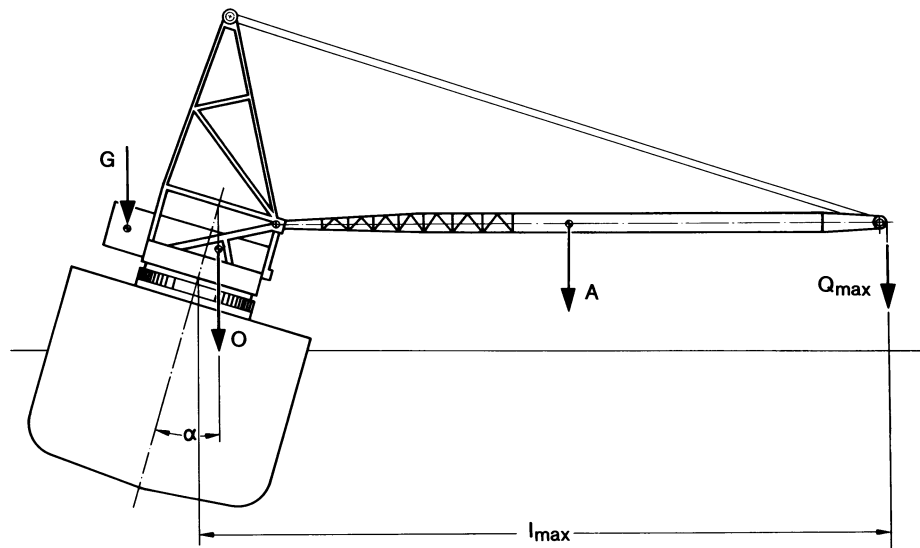

3. Kran außer Betrieb,  
Ausleger abgelegt und gezurrt

Crane out of use,  
boom stowed

Grue hors service,  
flèche déposée et amarrée

Gru fuori servizio,  
braccio appoggiato e ardato

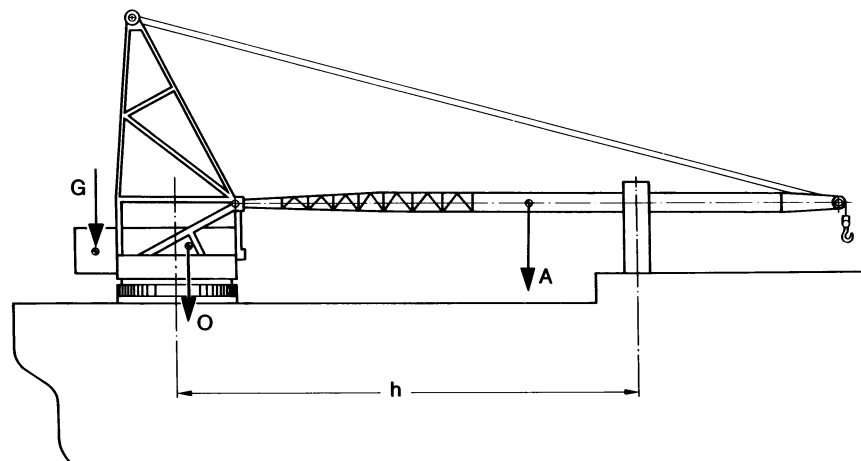

**Allgemeine Anfrage-Daten**  
**General enquiry data**  
**Données générales**  
**Dati generali della richiesta**

Falls für die Konstruktion des Lagers besondere Vorschriften (Stoßfaktoren, Überlasten, Testlasten usw.) einer Klassifikationsgesellschaft berücksichtigt werden müssen, sind uns die für die Berechnung des Lagers einzusetzenden Lasten bekanntzugeben.

If special material specifications are required (shock factors, overloads, test loads etc.) then the material specification stipulated by the Classifying Authority must be given with the enquiry.

Dans le cas où des prescriptions particulières (facteurs de choc, surcharges, charges d'essai, etc...) émanant d'organismes de classification ou de réception doivent être prises en compte pour la conception de la couronne, veuillez nous communiquer les charges à considérer pour son calcul.

Qualora per il progetto ed il dimensionamento del cuscinetto dovessero essere osservate particolari normative (fattori d'urto, sovraccarichi, carichi di test ecc.) di un ente di classificazione, debbono esserci resi noti i carichi da considerare nel calcolo di verifica del cuscinetto.

Max. Drehzahl Max. speed Vitesse rotation max. Max. numero giri	n = _____ min <sup>-1</sup> n = _____ rpm n = _____ t/mn n = _____ min <sup>-1</sup>	(Alle Maße ab Lageroberkante bzw. Drehachse) (All measurements from bearing surface or axis of rotation) (Toutes dimensions à partir de l'arête supérieure couronne ou de l'axe de rotation) (Tutte le quote riferite al bordo superiore del cuscinetto rispetto all'asse di rotazione)	Max. Radiallast aus Wind ... Max. radial load from wind ... Charge radiale maxi due au vent ... Mass. forza radiale dovuta al vento ...
Gewichte Weights Poids Pesi	O = _____ t A = _____ t G = _____ t Q <sub>max</sub> = _____ t	Drehmoment am Zahnkranz normal Torque at the gear ring normal Couple normal à la bague dentée Coppia normale di rotazione sulla corona dentata	W = _____ kN y = _____ m z = _____ m
Maße Dimensions Dimensions Quote	o = _____ m a = _____ m g = _____ m d = _____ m e = _____ m f = _____ m c = _____ m l <sub>max</sub> = _____ m	Md <sub>2</sub> = _____ kNm	
		Max. Radiallast aus dem Antrieb Max. radial load from drive Charge radiale maxi due à l'entraînement Mass. forza radiale dovuta al gruppo di rotazione	
		Fr = _____ kN	

Gewichte Weights Poids Pesi	O = _____ t A = _____ t G = _____ t Q <sub>max</sub> = _____ t	(Alle Maße ab Lageroberkante bzw. Drehachse) (All measurements from bearing surface or axis of rotation) (Toutes dimensions à partir de l'arête supérieure couronne ou de l'axe de rotation) (Tutte le quote riferite al bordo superiore del cuscinetto rispetto all'asse di rotazione)	Max. Radiallast aus Wind ... Max. radial load from wind ... Charge radiale maxi due au vent ... Mass. forza radiale dovuta al vento ...
Maße Dimensions Dimensions Quote	l <sub>max</sub> = _____ m α <sub>max</sub> = _____ °	Drehmoment am Zahnkranz normal Torque at the gear ring normal Couple normal à la bague dentée Coppia normale di rotazione sulla corona dentata	Resultierende Beschleunigung aus Rollen und Stampfen Acceleration resulting from rolling and pitching Accélération résultant du roulis et du tangage Accelerazione risultante dovuta al rollio e beccheggio
		Md <sub>2</sub> = _____ kNm	B = _____ g
		Max. Radiallast aus dem Antrieb Max. radial load from drive Charge radiale maxi due à l'entraînement Mass. forza radiale dovuta al gruppo di rotazione	
		Fr = _____ kN	

Gewichte Weights Poids Pesi	O = _____ t A = _____ t G = _____ t Q <sub>max</sub> = _____ t	(Alle Maße ab Lageroberkante bzw. Drehachse) (All measurements from bearing surface or axis of rotation) (Toutes dimensions à partir de l'arête supérieure couronne ou de l'axe de rotation) (Tutte le quote riferite al bordo superiore del cuscinetto rispetto all'asse di rotazione)	Max. Radiallast aus Wind ... Max. radial load from wind ... Charge radiale maxi due au vent ... Mass. forza radiale dovuta al vento ...
G = 0; wenn Gegengewicht auf Deck abgelegt G = 0; when counterweight has been deposited on deck G = 0; quand le contre-poids est déposé sur le pont G = 0; quando il contropeso è appoggiato in coperta			W = _____ kN
Maße Dimensions Dimensions Quote	h = _____ m α = _____ ° bei maximaler Krängung at maximum heel pour gîte maxi con mass. sbandata		Max. Beschleunigung aus Rollen und Stampfen Max. acceleration resulting from rolling and pitching Accélération maxi du roulis et du tangage Max. accelerazione risultante dovuta al rollio e beccheggio
			B = _____ g

<b>4.</b>	Betriebstemperatur Température de service	Operating temperature Temperatura di esercizio	von, from, de, da _____ K bis, to, à a _____ K	
<b>5.</b>	bevorzugter Lager-Ø Ø de couronne souhaité	Preferred bearing dia. Diametro preferenziale del cuscinetto	von, from, de, da _____ mm bis, to, à a _____ mm	
<b>6.</b>	Verzahnung Denture	Gear Dentatura	innen – außen – ohne / internal – external – without intérieure – extérieure – sans / interna – esterna – senza	
6.1	Verzahnung Denture	Gear Dentura	am feststehenden oder drehenden Konstruktionsteil on the fixed or the rotating part of machine sur partie fixe ou mobile sulla parte fissa oppure rotante della struttura collegata	
<b>7.</b>	Ritzeldaten Caractéristiques pignon	Pinion data Dati del pignone di comando	=	
7.1	Modul Module	Module (pitch) Modulo	m =	
7.2	Eingriffswinkel Angle de pression	Pressure angle Angolo di pressione	$\alpha_o = 20^\circ$	
7.3	Zähnezahl Nombre de dents	Number of teeth Numero denti	z <sub>1</sub> =	
7.4	Profilverschiebung Déport de profil	profile correction Correzione nominale del profilo	x <sub>1</sub> · m =	
7.5	Kopfkürzung Troncature	Addendum reduction Troncatura di testa	k <sub>1</sub> · m =	
7.6	Ritzel wird auf Wunsch mitgeliefert Le pignon peut être livré sur demande	Pinion will be supplied upon demand Su richiesta è possibile la fornitura del pignone	ggf. Ritzelzeichnung beifügen Zeichnungs-Nr.: _____ Dans ce cas joindre un plan du pignon plan Nr.: _____	Please furnish drawing: _____ Eventualmente allegare disegno del pignone Disegno N°: _____
<b>8.</b>	Bisherige Lagerung Disposition précédente de la couronne	Existing method of slewing Supporto attuale	Zeichnung bitte beifügen Unterlagen: _____ Joindre un plan Documents: _____	Please enclose drawing: _____ Allegare disegno Documentazione: _____
<b>9.</b>	Anmerkung Remarques	Remarks Note		
Für die Ausarbeitung wirtschaftlicher Vorschläge bitten wir, dieser Berechnungsunterlage unbedingt Zeichnungen sowie Belastungsskizzen beizufügen.		Unterlagen: _____		
For the most economical proposal, it would be appreciated if you enclose drawings and load sketches of the actual application.		Documents: _____		
Pour l'étude d'une proposition économique nous vous prions de joindre les notes de calcul, plans et schémas des charges.		Documents: _____		
Per facilitare la stesura di proposte economiche allegare per quanto possibile disegni e schemi di carico alla richiesta.		Documentazione: _____		
<b>Firma / Company / Société / Ditta:</b>		<b>Sachbearbeiter / Projekt Engineer / Affaire suivie par / Elaborato da:</b>		
_____		_____		
Anschrift / Address / Adresse / Indirizzo:		Datum / Date / Date / Data:		
_____		_____		



**Rothe Erde GmbH**  
 Tremoniastraße 5-11  
 D-44137 Dortmund  
 Tel.: (02 31) 186-0  
 Fax: (02 31) 186-25 00  
 E-mail: rotheerde@tkr-re.thyssenkrupp.com  
 Internet: www.rotheerde.com