

# NSK Ball Screws for Standard Stock Compact FA Series

Next-generation compact ball screws offer quiet,  
high speed operating performance.  
A standard stock series assures immediate delivery.



Patent Pending



# BSS Series next-generation compact ball screws offer quiet, high-speed performance, now available in standard stock.

BSS Series next-generation compact ball screws incorporate the new ball recirculation system and offer quiet, high-speed performance. In order to respond quickly to a wide range of needs, NSK keeps these ball screws in standard stock as the Compact FA Series. The exceptionally high performance ball screws are ready for use in a variety of fields such as semiconductor manufacturing equipment, LCD manufacturing equipment, chip mounting equipment, measuring apparatus, and medical equipment.

## Features

### 6 dB less noise

The noise level of ball screws has been reduced by 6 dB, about half of what is sensed by the ear. Ball screws subsequently produce a quieter and gentler sound.

### 10%–30% more compact ball nut

The outside diameter of the ball nut is as much as 30% smaller than those of NSK conventional products. This contributes to more compact design of all sorts of equipment and devices such as thinner XY tables.

### High-speed operation of up to 5 000 min<sup>-1</sup>

The new ball screws offer 1.6 times faster rotational speed than conventional ball screws. They handle speeds up to 5 000 min<sup>-1</sup>. This capability dramatically expands the range of service conditions. Note: Please refer to the dimension table for details of permissible rotational speed.

### Grease fitting provided as standard equipment

The new ball screws are standardly equipped with a grease fitting (M5 × 0.8). Lubrication ports are provided in 2 places to facilitate maintenance. The ball screws can be easily connected to an integrated lubrication system.

### New type of contact seal

A new model high-performance contact seal minimizes grease dispersion and helps to maintain a clean work environment.

### Low-profile design

The low-profile support units especially compatible with the compact FA series are available for uniquely space-saving design.

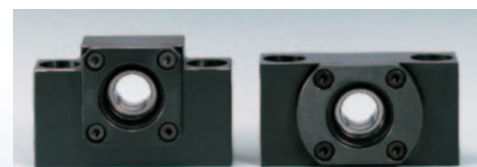

Existing support unit ⇒ New low-profile support unit

Example of reference number: **PSS 15 20 N1D 0561**

Compact FA Series

Accuracy grade: C5

Screw shaft diameter (mm)

Ball screw shaft length L<sub>3</sub> (mm)

NSK control No.

Lead (mm)

As much as **30%** more compact

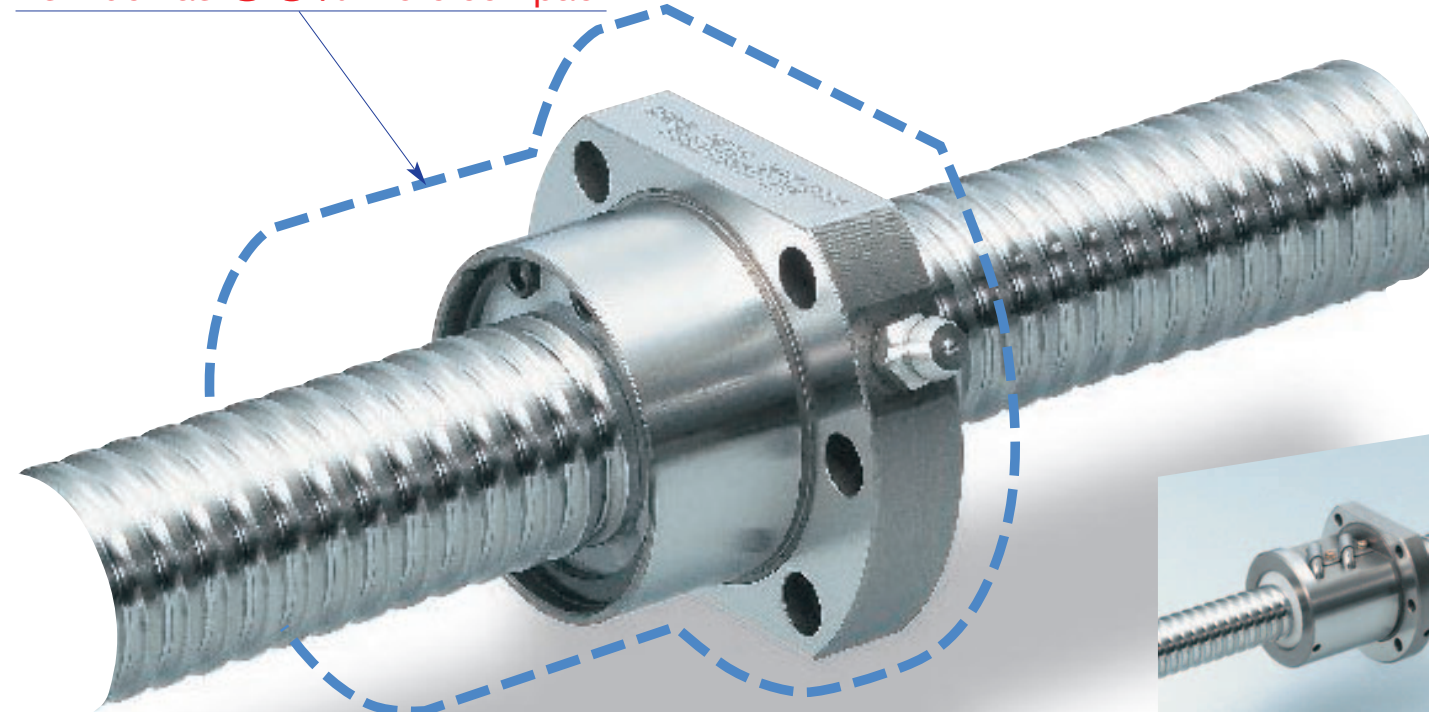

Comparison of conventional FA Series and Compact FA Series

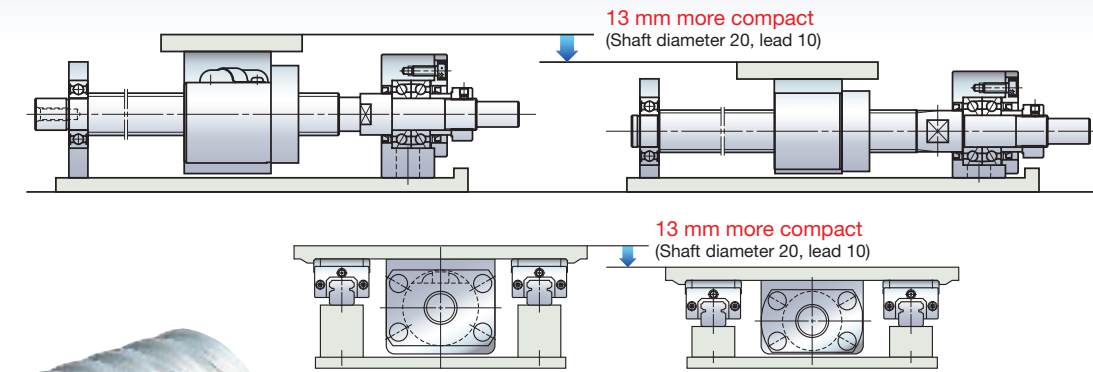

## Specifications

- Accuracy grade: C5 class is available.
  - Axial play: 0 (oversize ball preload)
- Consult with NSK for information on surface treatment.

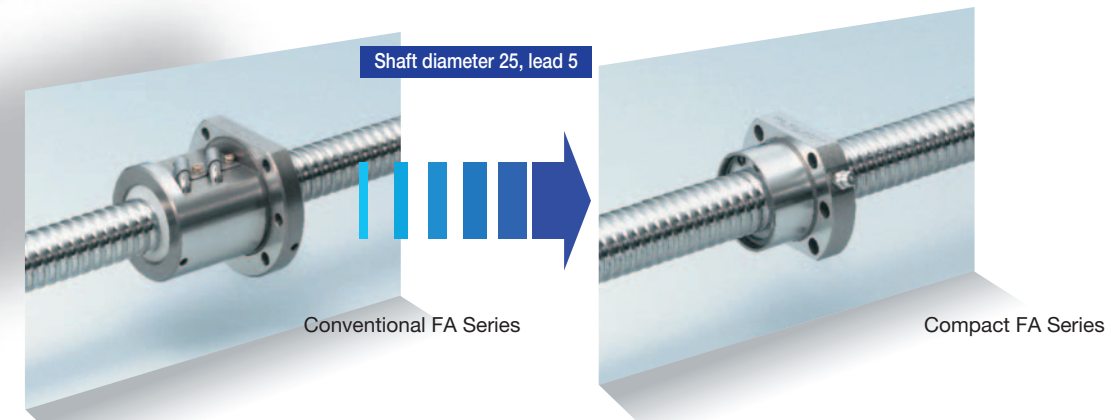

# Compact & Silent

Noise data

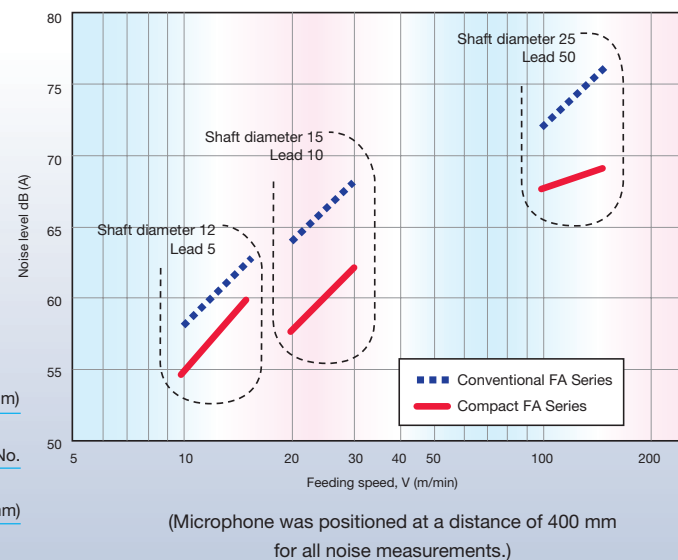

Application: Combination of shaft diameter and lead are shown in the table.

Shaft diameter	Lead	Stroke														Recommended support unit		
		50	100	150	200	300	400	500	600	700	800	1 000	1 200	1 600	2 000	Fixed side support unit	Simple side support unit	
10	5	●	●	●	●	●	●										WBK08-01B	WBK08S-01B
	10		●	●	●	●	●											
12	5	●	●	●	●	●	●										WBK08-01B	WBK08S-01B
	10		●	●	●	●	●											
	20		●	●	●	●	●											
15	5	●	●	●	●	●	●	●	●	●	●	●					WBK12-01B	WBK12S-01B
	10		●	●	●	●	●	●	●	●	●	●					WBK10-01B	
	20		●	●	●	●	●	●	●	●	●	●						
20	5			●	●	●	●	●	●	●	●	●	●	●			WBK15-01B	WBK15S-01B
	10			●	●	●	●	●	●	●	●	●	●	●				
	20			●	●	●	●	●	●	●	●	●	●	●				
	30			●	●	●	●	●	●	●	●	●	●	●				
25	5				●	●	●	●	●	●	●	●	●	●				
	10				●	●	●	●	●	●	●	●	●	●			WBK20-01	WBK20S-01
	20				●	●	●	●	●	●	●	●	●	●				
	25				●	●	●	●	●	●	●	●	●	●				
	30				●	●	●	●	●	●	●	●	●	●				
50	5						●	●	●	●	●	●	●	●				
	10						●	●	●	●	●	●	●	●				

Other support units are also available. See last page of catalog for details.

#### Screw shaft $\phi 10$ Lead 5, 10

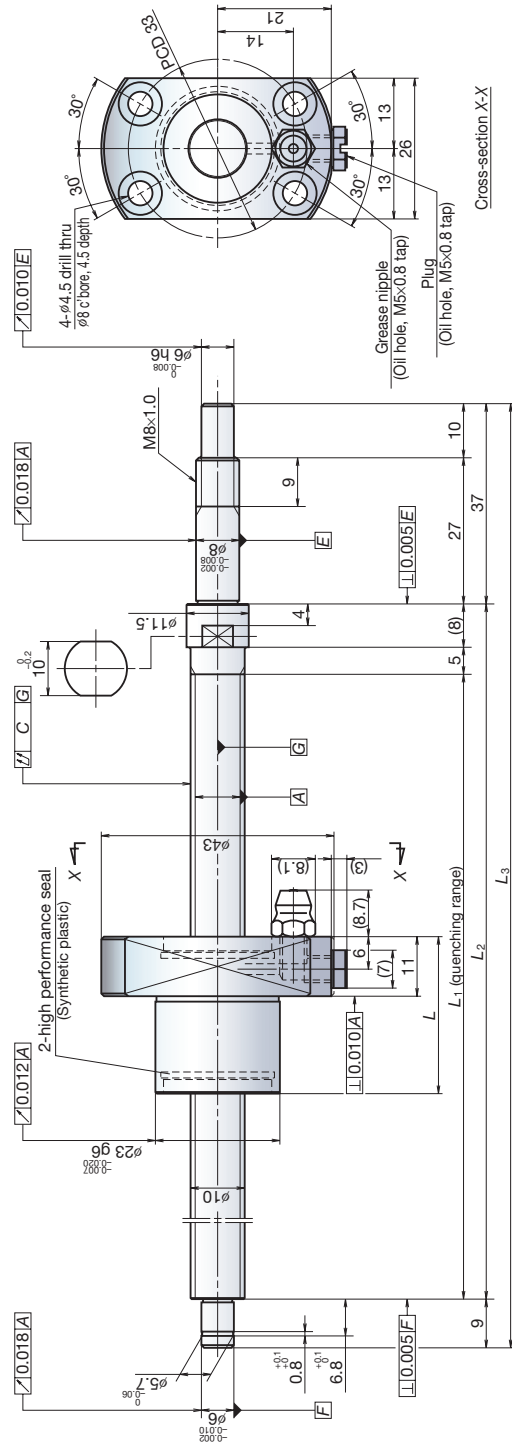

#### Ball screw specification

Preload type	Oversize ball preload (P-preload)
Ball diameter/screw shaft root diameter	2.000/8.2
Accuracy grade/axial play	C5/0
Factory pre-packed grease	NSK grease PS2

#### Recommended support unit

WBK08-01B	(square, fixed side)
WBK08S-01B	(square, simple side)
WBK08-11B	(round, fixed side)

Reference number	Screw shaft diameter $d$	Lead $\ell$	Basic load ratings (N)		Stroke	Nut length $L$	Screw shaft dimensions			Lead accuracy		Shaft runout, C	Dynamic preload torque (N-cm) <sup>*1</sup>	Permissible rotational speed (min <sup>-1</sup> ) <sup>*2</sup> Fixed-Simple
			Dynamic $C_a$	Static $C_{0a}$			Nominal $L_1-L$	Max. $L_1-L$	$L_1$	$L_2$	$L_3$			
PSS1005N1D0171	10	5	50	83	50	29	112	125	171	0	0.020	0.018	0.7	3.3
PSS1005N1D0221			100	133	100	29	162	175	221	0	0.020	0.018	0.7	3.3
PSS1005N1D0321			200	233	200	29	262	275	321	0	0.023	0.018	0.6	4.3
PSS1005N1D0421			300	333	300	29	362	375	421	0	0.025	0.020	0.6	4.3
PSS1005N1D0521	10	10	400	433	400	32	462	475	521	0	0.027	0.020	0.4	4.9
PSS1010N1D0221			100	130	100	32	162	175	221	0	0.020	0.018	0.7	3.3
PSS1010N1D0321			200	230	200	32	262	275	321	0	0.023	0.018	0.6	4.3
PSS1010N1D0421			300	330	300	32	362	375	421	0	0.025	0.020	0.6	4.3
PSS1010N1D0521	12	10	400	430	400	32	462	475	521	0	0.027	0.020	0.4	4.9

\*1. Indicates ball screw preload control value. About 2.0 N-cm of torque is added due to high performance seal. \*2. Contact NSK if permissible rotational speed is to be exceeded. \*3. Service temperature range is -20°C to 80°C.

#### Screw shaft $\phi 12$ Lead 5, 10, 20, 30

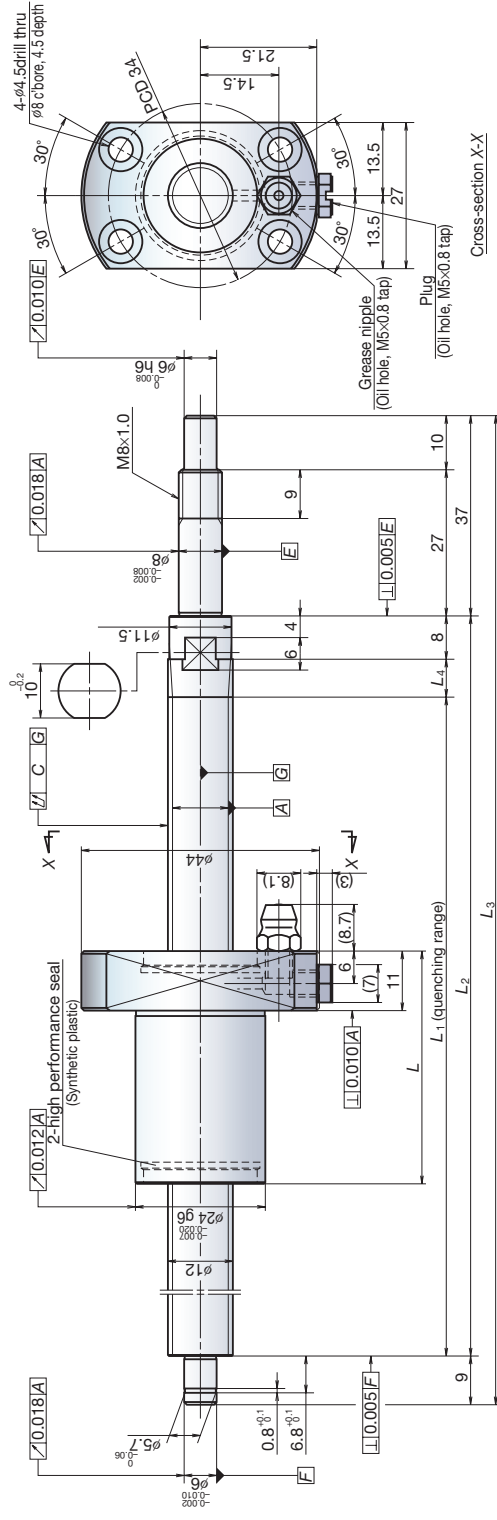

#### Ball screw specification

Preload type	Oversize ball preload (P-preload)
Ball diameter/screw shaft root diameter	2.000/10.2
Accuracy grade/axial play	C5/0
Factory pre-packed grease	NSK grease PS2

#### Recommended support unit

WBK08-01B	(square, fixed side)
WBK08S-01B	(square, simple side)
WBK08-11B	(round, fixed side)

Reference number	Screw shaft diameter $d$	Lead $\ell$	Basic load ratings (N)		Stroke	Nut length $L$	Screw shaft dimensions			Lead accuracy		Shaft runout, C	Dynamic preload torque (N-cm) <sup>*1</sup>	Permissible rotational speed (min <sup>-1</sup> ) <sup>*2</sup> Fixed-Simple
			Dynamic $C_a$	Static $C_{0a}$			Nominal $L_1-L$	Max. $L_1-L$	$L_1$	$L_2$	$L_3$			
PSS1205N1D0171	10	5	50	80	50	30	110	125	171	0	0.020	0.018	0.7	3.3
PSS1205N1D0221			100	130	100	30	160	175	221	0	0.020	0.018	0.7	3.3
PSS1205N1D0321			200	230	200	30	260	275	321	7	0.023	0.018	0.6	4.3
PSS1205N1D0421			300	330	300	30	360	375	421	7	0.025	0.020	0.6	4.3
PSS1205N1D0521	12	10	400	430	400	32	460	475	521	0	0.027	0.020	0.6	4.3
PSS1205N1D0621			500	530	500	32	560	575	621	9	0.030	0.023	0.6	4.9
PSS1210N1D0221			100	117	100	32	160	175	221	9	0.020	0.018	0.7	3.3
PSS1210N1D0321			200	217	200	32	260	275	321	9	0.023	0.018	0.6	4.3
PSS1210N1D0421	12	10	300	317	300	32	360	375	421	0	0.025	0.020	0.6	4.3
PSS1210N1D0521			400	417	400	32	460	475	521	0	0.027	0.020	0.6	4.3
PSS1210N1D0621			500	517	500	32	560	575	621	0	0.030	0.023	0.6	4.9
PSS1220N1D0371			200	258	200	32	308	325	371	14	0.023	0.018	0.4	4.5
PSS1220N1D0471	12	20	300	358	300	50	408	425	471	0	0.027	0.020	0.9	4.9
PSS1220N1D0571			400	458	400	50	508	525	571	14	0.030	0.023	0.6	5.9
PSS1230N1D0671			500	558	500	50	608	625	671	14	0.030	0.023	0.6	5.9
PSS1230N1D0771			100	133	100	32	203	225	271	14	0.023	0.018	0.4	4.5
PSS1230N1D0871	12	30	200	233	200	70	303	325	371	0	0.023	0.018	0.6	5.0
PSS1230N1D0471			300	333	300	70	403	425	471	14	0.027	0.020	0.9	4.9
PSS1230N1D0571			400	433	400	70	503	525	571	14	0.030	0.023	0.6	5.9
PSS1230N1D0671			500	533	500	70	603	625	671	14	0.030	0.023	0.6	5.9

\*1. Indicates ball screw preload control value. About 2.0 N-cm of torque is added due to high performance seal. \*2. Contact NSK if permissible rotational speed is to be exceeded. \*3. Service temperature range is -20°C to 80°C.



Screw shaft  $\phi 20$   
Lead 5, 10, 20, 30, 40, 60

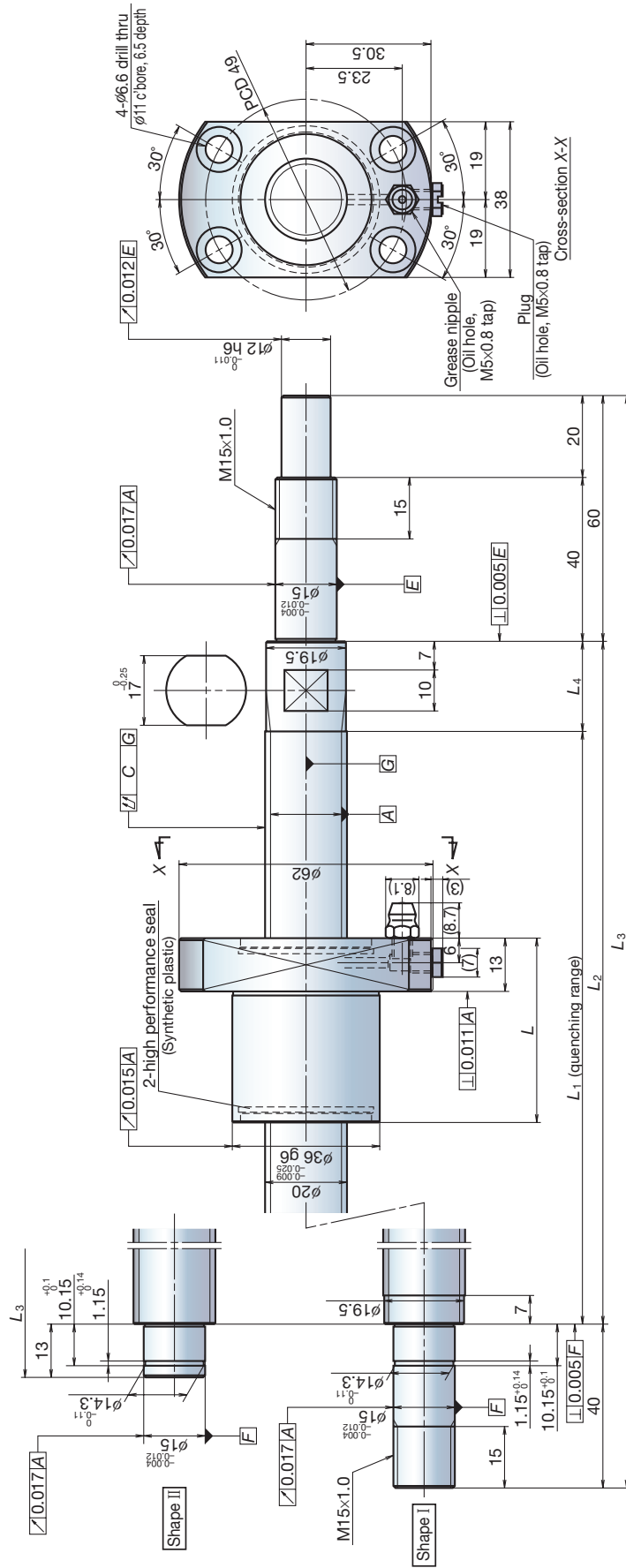

#### Ball screw specification

Preload type	Oversize ball preload (P-preload)
Ball diameter/screw shaft root diameter	3.175/17.2
Accuracy grade/axial play	C5/0
Factory pre-packed grease	NSK grease LR3

#### Recommended support unit

WBK15-01B	(square, fixed side)
WBK15S-01B	(square, simple side)
WBK15-11	(round, fixed side)

Reference number	Screw shaft diameter $d$	Lead $\ell$	Basic load ratings (N)		Stroke	Nut length $L$	Screw shaft dimensions					Lead accuracy		Shaft runout $C$	Dynamic preload torque (N·cm) *1	Permissible rotational speed (min <sup>-1</sup> ) *2		Left shaft end (opposite driven side)
			Dynamic $C_a$	Static $C_{0a}$			Nominal $L_1-L$	Max. $L_1-L$	$L_1$	$L_2$	$L_3$	$L_4$	Target value $T$			Error $e_p$	Variation $v_u$	
PSS2005N1D0323	20	5	8 790	18 500	150	197	31	228	250	323	22	0.023	0.018	0.045	0.6	-	Shape II	
PSS2005N1D0373								278	300	373								
PSS2005N1D0473								378	400	473								
PSS2005N1D0573								478	500	573								
PSS2005N1D0673								578	600	673								
PSS2005N1D0773								678	700	773								
PSS2005N1D0873		778	800	873	45	0.035	0.025	0.075	0.4	9.8								
PSS2005N1D1000		878	900	1000														
PSS2010N1D0387		292	314	387														
PSS2010N1D0487		392	414	487														
PSS2010N1D0587		492	514	587														
PSS2010N1D0687		592	614	687														
PSS2010N1D0787	692	714	787	54	0.040	0.027	0.120	0.8	13.8									
PSS2010N1D0887	792	814	887															
PSS2010N1D1014	892	914	1014															
PSS2010N1D1214	1 092	1 114	1 214															
PSS2010N1D1414	1 292	1 314	1 414															
PSS2020N1D0508	413	435	508															
PSS2020N1D0608	513	535	608	74	0.030	0.023	0.060	1.4	11.8									
PSS2020N1D0708	613	635	708															
PSS2020N1D0808	713	735	808															
PSS2020N1D0908	813	835	908															
PSS2020N1D1035	913	935	1 035															
PSS2020N1D1235	1 113	1 135	1 235															
PSS2020N1D1435	1 313	1 335	1 435	92	0.046	0.030	0.160	0.8	13.8									
PSS2020N1D1835	1 600	1 659	1 835															
PSS2030N1D0408	308	335	408															
PSS2030N1D0508	408	435	508															
PSS2030N1D0608	508	535	608															
PSS2030N1D0708	608	635	708															
PSS2030N1D0808	708	735	808	129	0.040	0.027	0.200	0.8	14.8									
PSS2030N1D0908	808	835	908															
PSS2030N1D1035	908	935	1 035															
PSS2030N1D1235	1 108	1 135	1 235															
PSS2030N1D1435	1 308	1 335	1 435															
PSS2040N1D0658	553	585	658															
PSS2040N1D0758	653	685	758	32	0.030	0.025	0.075	2.2	12.8									
PSS2040N1D0858	753	785	858															
PSS2040N1D0958	853	885	958															
PSS2040N1D1085	953	985	1 085															
PSS2040N1D1285	1 153	1 185	1 285															
PSS2040N1D1485	1 353	1 385	1 485															
PSS2040N1D1885	1 753	1 785	1 885	42	0.040	0.027	0.160	1.8	14.8									
PSS2040N1D2285	2 000	2 061	2 285															
PSS2060N1D0708	400	464	508															
PSS2060N1D0808	500	564	608															
PSS2060N1D0908	600	664	708															
PSS2060N1D1008	700	764	808															
PSS2060N1D1135	800	864	935	1 135	0.040	0.027	0.160	1.8	14.8									
PSS2060N1D1335	1 000	1 064	1 135															
PSS2060N1D1535	1 193	1 254	1 335															
PSS2060N1D1735	1 393	1 435	1 535															
PSS2060N1D1935	1 793	1 835	1 935															
PSS2060N1D2335	2 000	2 064	2 335															

\*1. Indicates ball screw preload control value. About 3.0 N·cm of torque is added due to high performance seal. \*2. Contact NSK if permissible rotational speed is to be exceeded. \*3. Service temperature range is -20°C to 80°C.



## Precautions

### Design

- (1) If a ball screw of which left shaft end (opposite driven side) is the shape I, and is supported with the “fixed-fixed” supporting method, you should be aware that the operating life of support bearings may drop due to thermal expansion of the screw shaft, depending on usage conditions. In this case, you should consider a structure that can absorb thermal expansion of the screw shaft if necessary. Please consult with NSK for a detailed examination.
- (2) If using an NSK linear guide, the maximum speed of a linear guide of standard specifications under ordinary conditions is limited to 100 m/min. A linear guide with high-speed specifications is available if higher operating speed is required. Contact NSK for further information.
- (3) For general precautions concerning ball screws, please see NSK Catalog No. E3161 “Precision Machine Components.”

### Usage and handling

Ball screws are precision products and should be treated as follows:

#### [Lubrication]

- (1) Compact FA Series ball screws are packed and coated with lubrication grease at the factory, and require no further lubrication under ordinary circumstances. If the surface of the grease becomes contaminated with dirt and metal powder under operation, clean it with white kerosene and replenish with new grease of the same kind through the oil hole (grease nipple) on the ball nut. Avoid mixing different types of grease.
- (2) Lubricant should be checked after the first 2 to 3 months of operation. If excessively dirty, we recommend you wipe away the old grease and replenish with a generous quantity of grease. After that, grease should be checked and replenished once a year under ordinary circumstances, but the period may vary depending upon the service environment.

#### [Handling]

- (1) Never disassemble the ball screw, otherwise dirt may contaminate the inside of the unit and affect precision or result in equipment failure.
- (2) Compact FA Series ball screws incorporate a new ball re-circulation system. Consequently, only NSK authorized plants should conduct disassembly and reassembly. If the nut accidentally comes off the screw shaft or is dropped, NSK will check precision, problems or perform repairs at your expense.
- (3) When the ball screw is erected upright, the screw shaft or nut could fall by force of its own weight and result in injury. If dropped, the ball grooves could be dented or re-circulation parts damaged, resulting in loss of function. This would require the ball screw to be inspected by NSK. If so, be sure to send the ball screw to NSK and we will check it for a fee.

#### [Usage]

- (1) Ball screws should be used in a clean environment. The ball screws should be provided with a dust cover to prevent the entry of debris such as dust and metal powder. If foreign matter is allowed to contaminate the ball screw, this could not only cause the ball screw to lose some of its function, but also result in clogging and damaging the re-circulation system parts, or cause the table to fall or a similar serious accident.
- (2) Compact FA Series ball screws are designed to be used in a service temperature environment of 80°C or lower. Do not allow the service temperature limit to be exceeded. In some cases, using ball screws in temperatures above 80°C might lead to damage of re-circulation system parts or seal parts. Contact NSK if 80°C must be exceeded.

### Compact FA Series options

Consult with NSK for information about optional specification not given in the catalog such as shaft end machining, reverse direction ball nut, alternative grease, surface treatment, and alternative preload.



Check lubrication



Do not disassemble



Beware of dropping



Dust control



Caution max. temperature

NSK has developed a series of low-profile support unit to be used with the ball screws of compact FA series. A combination of the ball screw and the support unit offers a compact design for downsizing of many kinds of machinery.

### Features

The low-profile support units offer the low center height construction suited for the compact FA series ball screws.

### Product configuration

All parts required for ball screw mounting are provided as a set (see the table below). The bearing housing of support unit for fixed side contains a built-in angular contact ball bearings and oil seal and should not be disassembled.

Fixed side support unit

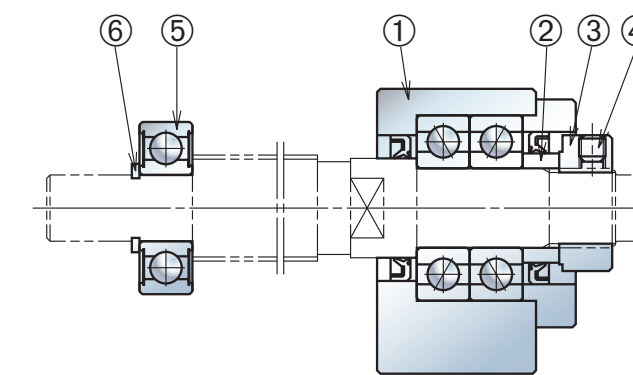

Part No.	Part	Remarks (surface treatment, grease)
	Bearing housing	Triiron tetroxide film
①	Angular contact ball bearing, PS2	
	Oil seal	
	Cover	Triiron tetroxide film
②	Spacer	
③	Lock nut	Triiron tetroxide film
④	Setscrew	Triiron tetroxide film
	Set piece (pad)	
⑤	Deep groove ball bearing	Comes with support side, PS2
⑥	Snap ring	Triiron tetroxide film

Other machine screws are either made of stainless steel or coated with triiron tetroxide film.

Simple side support unit

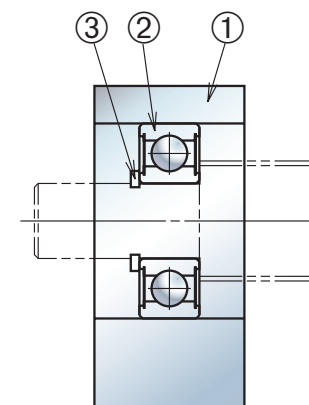

Part No.	Part	Remarks (surface treatment, grease)
①	Bearing housing	Triiron tetroxide film
②	Deep groove ball bearing	PS2
③	Snap ring	Triiron tetroxide film

### Reference number

Example: **WBK 08 S - 01 B**

Support unit product code: WBK

Nominal size code (internal bore of bearing)\*: 08

Mounting code: S (No code: Fixed side support unit, S: Simple side support unit)

Support unit type: 01 (01: Square type, 11: Round type)

Support unit profile: B (No code or A: conventional standard support unit, B: Low-profile support unit)

\*For simple side support units, please note that size codes of 12 or less do not represent internal bores of bearing.

Fixed side support unit (square type)

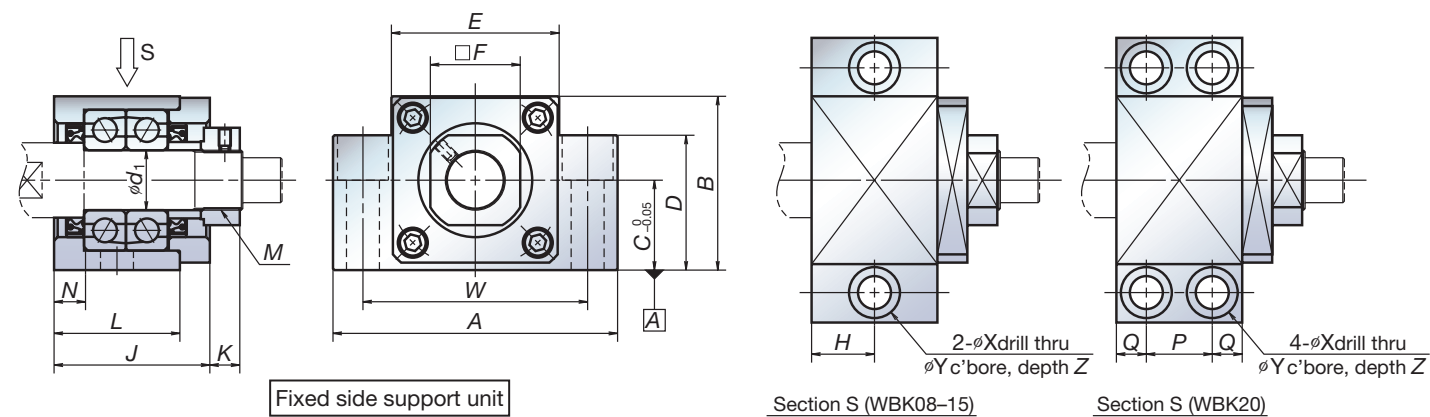

Fixed side support unit (round type)

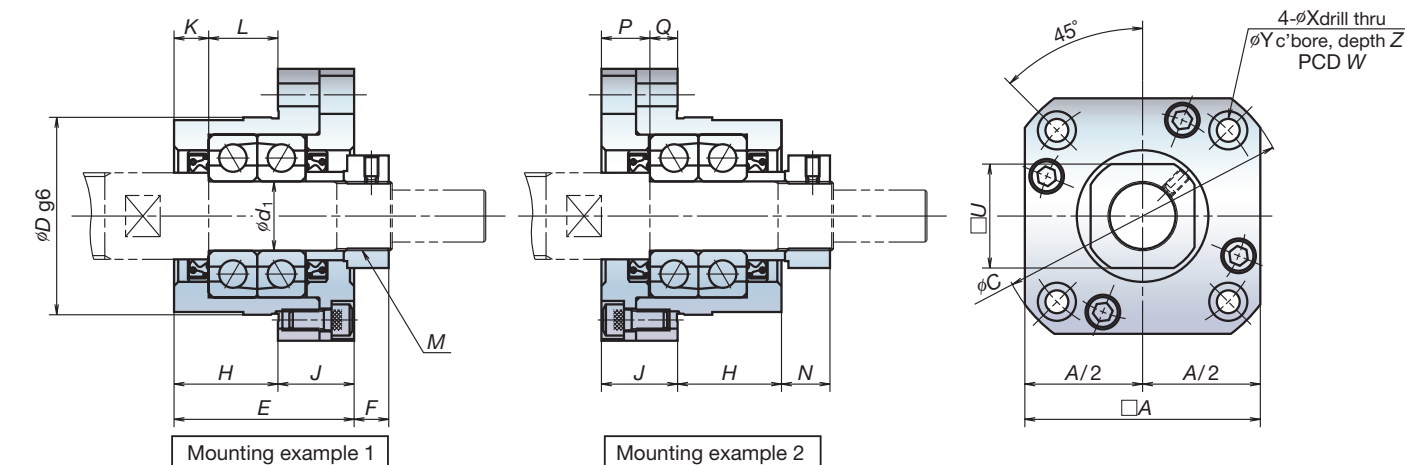

Unit: mm

Screw shaft diameter	Fixed side support unit (square type)																			
	Reference number	$d_1$	A	B	C	D	E	F	H	J	K	L	N	P	Q	W	X	Y	Z	M
φ 10	WBK08-01A	8	52	32	17	26	25	14	11.5	23	7	—	4	—	—	38	6.6	11	12	M8X1
φ 12	WBK08-01B	8	62	31	15.5	—	—	14	11	25.5	4.5	21.5	3.5	—	—	46	9	14	18	M8X1
φ 15	WBK10-01B*	10	70	38	20	—	—	17	12	30	5.5	24	6	—	—	52	9	14	19	M10X1
	WBK12-01A	12	70	43	25	35	36	19	12	30	5.5	24	6	—	—	52	9	14	11	M12X1
φ 20	WBK12-01B	12	70	38	20	—	—	19	12	30	5.5	24	6	—	—	52	9	14	19	M12X1
	WBK15-01A	15	80	50	30	40	41	22	12.5	31	12	25	5	—	—	60	11	17	15	M15X1
φ 25	WBK15-01B	15	80	42	22	—	—	22	12.5	31	12	25	5	—	—	60	11	17	23	M15X1
	WBK20-01	20	95	58	30	45	56	30	—	52	10	42	10	22	10	75	11	17	15	M20X1

\*Use support unit for fixing side for opposite drive side of shaft diameter φ15.  
 Remarks 1. Mount to the base using side A as the reference.  
 2. Tighten the setscrew after tightening the lock nut and adjusting.  
 3. Insert the set piece and then tighten the setscrew.

Simple side support unit

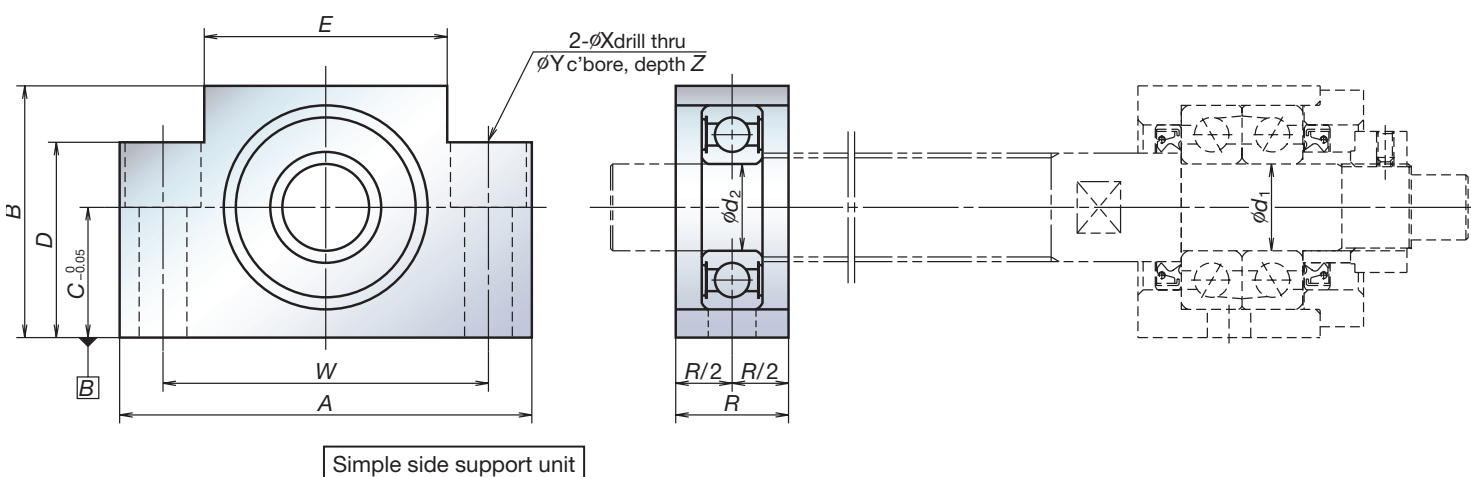

Unit: mm

Screw shaft diameter	Simple side support unit												
	Reference number	$d_2$	A	B	C	D	E	R	W	X	Y	Z	
φ 10	WBK08S-01	6	52	32	17	26	25	15	38	6.6	11	12	
φ 12	WBK08S-01B	6	62	31	15.5	—	—	16	46	9	14	18	
φ 15	WBK12S-01	10	70	43	25	35	36	20	52	9	14	11	
	WBK12S-01B	10	70	38	20	—	—	20	52	9	14	19	
φ 20	WBK15S-01	15	80	50	30	40	41	20	60	9	14	11	
	WBK15S-01B	15	80	42	22	—	—	20	60	9	14	23	
φ 25	WBK20S-01	20	95	58	30	45	56	26	75	11	17	15	

Remarks 1. Mount to the base using side B as the reference.

Unit: mm

Screw shaft diameter	Fixed side support unit (round type)																			
	Reference number	$d_1$	A	C	D	E	F	H	J	K	L	N	P	Q	U	W	X	Y	Z	M
φ 10	WBK08-11	8	35	43	28	23	7	14	9	4	10	8	5	4	14	35	3.4	6.5	4	M8X1
φ 12	WBK08-11B	8	42	52	34	25.5	4.5	15.5	10	3.5	12	7	6	4	14	42	4.5	8	4	M8X1
φ 15	WBK10-11*	10	42	52	34	27	7.5	17	10	5	12	8.5	6	4	17	42	4.5	8	4	M10X1
	WBK12-11	12	44	54	36	27	7.5	17	10	5	12	8.5	6	4	19	44	4.5	8	4	M12X1
φ 20	WBK15-11	15	52	63	40	32	12	17	15	6	11	14	8	7	22	50	5.5	9.5	6	M15X1
φ 25	WBK20-11	20	68	85	57	52	10	30	22	10	20	14	14	8	30	70	6.6	11	10	M15X1

\*Use support unit for fixing side for opposite drive side of shaft diameter φ15.  
 Remarks 1. Tighten the setscrew after tightening the lock nut and adjusting.  
 2. Insert the set piece and then tighten the setscrew.

Specifications of support unit

Screw shaft diameter	Support unit reference number	Fixed side support unit				Simple side support unit			
		Axial load		Maximum starting torque [N-cm]	Tightening torque [N-cm]		Support unit reference number	Bearing number	Radial load Basic load ratings C [N]
		Basic load ratings $C_a$ [N]	Load limit [N]		Lock nut	Setscrew			
φ 10	WBK08-01A (square type)	4 400	1 450	0.88	490	69 (M3)	WBK08S-01	606ZZ	2 260
	WBK08-11 (round type)						—		
φ 12	WBK08-01B (square low-profile type)	6 600	2 730	1.9	930	147 (M4)	WBK08S-01B	6000ZZ	4 550
	WBK08-11B (round type)						—		
φ 15	WBK10-01B (square low-profile type)*	6 600	2 730	1.9	1 370	147 (M4)	WBK12S-01	6002ZZ	5 600
	WBK10-11 (round type)						—		
φ 20	WBK12-01A (square type)	7 100	3 040	2.1	2 350	147 (M4)	WBK12S-01B	—	—
	WBK12-01B (square low-profile type)						—		
φ 25	WBK12-11 (round type)	7 600	3 380	2.3	4 700	147 (M4)	WBK15S-01	—	—
	WBK15-01A (square type)						—		
φ 25	WBK15-01B (square low-profile type)	17 900	8 240	5.4	—	—	WBK15S-01B	6204ZZ	12 800
	WBK15-11 (round type)						—		
φ 25	WBK20-01 (square type)	—	—	—	—	—	WBK20S-01	—	—
	WBK20-11 (round type)						—		

\*Use support unit for fixing side for opposite drive side of shaft diameter φ15.