

# Miniature Monocarrier<sup>®</sup> MCM02, MCM03

Supports small conveyors and test equipment in a wide range of applications.

Compact, lightweight design saves space and delivers high performance.



Patent Pending

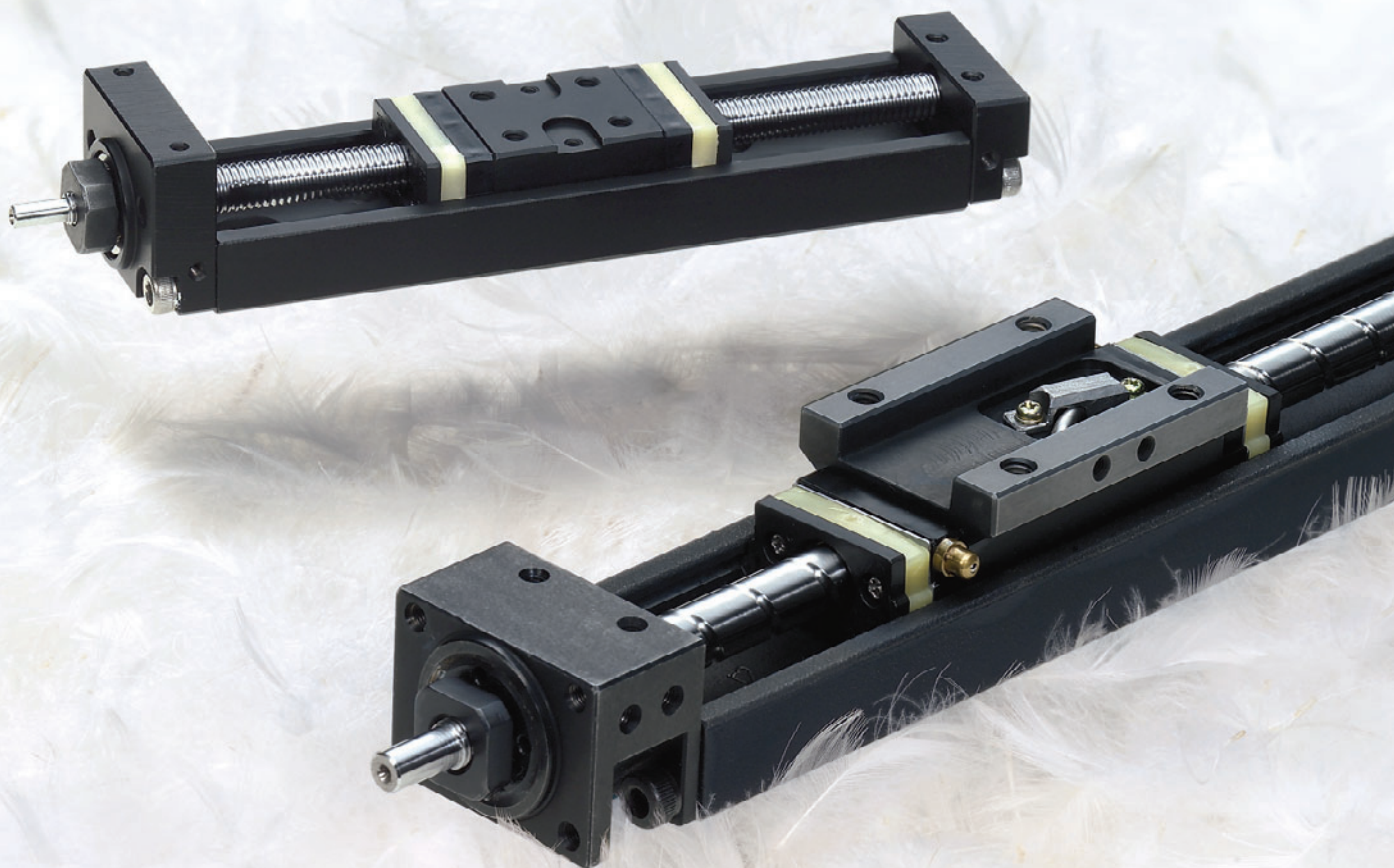

# Lightweight, space-saving structure made possible through compact design. These all-in-one Monocarriers are easy to use and provide high accuracy and rigidity.

Monocarriers are used in a variety of applications, including production, inspection, packaging and conveyance systems. Already recognized in the industry for improving efficiency and reducing labor, Monocarriers have been increasingly in demand to meet a growing range of needs. NSK has been developing a wide range of Monocarriers, making full use of its world-class technologies in ball screws and linear guides. To meet demand for smaller, lighter Monocarriers, NSK developed the MCM02 and MCM03, a series of compact Monocarriers that realizes unprecedented lightweight and space-saving features. In addition, these Monocarriers feature NSK's state-of-the-art technologies, such as a long life, maintenance-free NSK K1™ lubrication unit, an all-in-one structure for easy use, and high accuracy and rigidity, earning the product line a reputation for outstanding reliability. These small and lightweight Monocarriers are consequently well equipped to meet specific needs.

Stroke and lead of products with standard specification  
 (● mark: standard inventory, ● mark: made to order) Unit: mm

Reference number	MCM02				MCM03					
	1		2		1	2	10		12	
	High grade	Precision grade	High grade	Precision grade	Precision grade	High grade	Precision grade	High grade	Precision grade	
50	●	●	●	●	●	●	—	—	—	—
100	●	●	●	●	●	●	●	●	●	●
150	●	●	●	●	●	●	●	●	●	●
200	—	—	—	—	—	—	●	●	●	●
250	—	—	—	—	—	—	●	●	●	●

## Features

### 1. Lightweight, compact design

Integration of components minimizes cross-sectional dimensions, while reducing weight by one-half compared to existing combination units (single-axis tables). This compact design meets the demand for lighter weight and saving more space.

### 2. All-in-one structure

The all-in-one structure, integrating ball screw and linear guide into a single unit, significantly reduces workload for design and installation.

### 3. Long-term, maintenance-free operation

The NSK K1™ lubrication unit is incorporated into the guide and ball screw parts for the Monocarrier MCM02 and MCM03. The use of the NSK K1™ lubrication unit maintains smooth lubrication performance for long periods in mechanical environments where lubrication is difficult to apply, such as machinery and equipment for food processing and medical applications requiring a highly clean environment, thus enabling maintenance-free operation over an extended period of time.

### 4. Available in small and large ball screw leads

A range of standard sizes is available between 1 millimeter small lead to 12 millimeter large lead.

### 5. Anticorrosion feature

Special surface treatment is provided as a standard feature to prevent corrosion under various operating conditions.

### 6. High accuracy and rigidity

The concave main base, although lightweight, resists bending and can be used as cantilever beams. The structure, composed of several rolling elements, reduces friction and provides higher positioning accuracy.

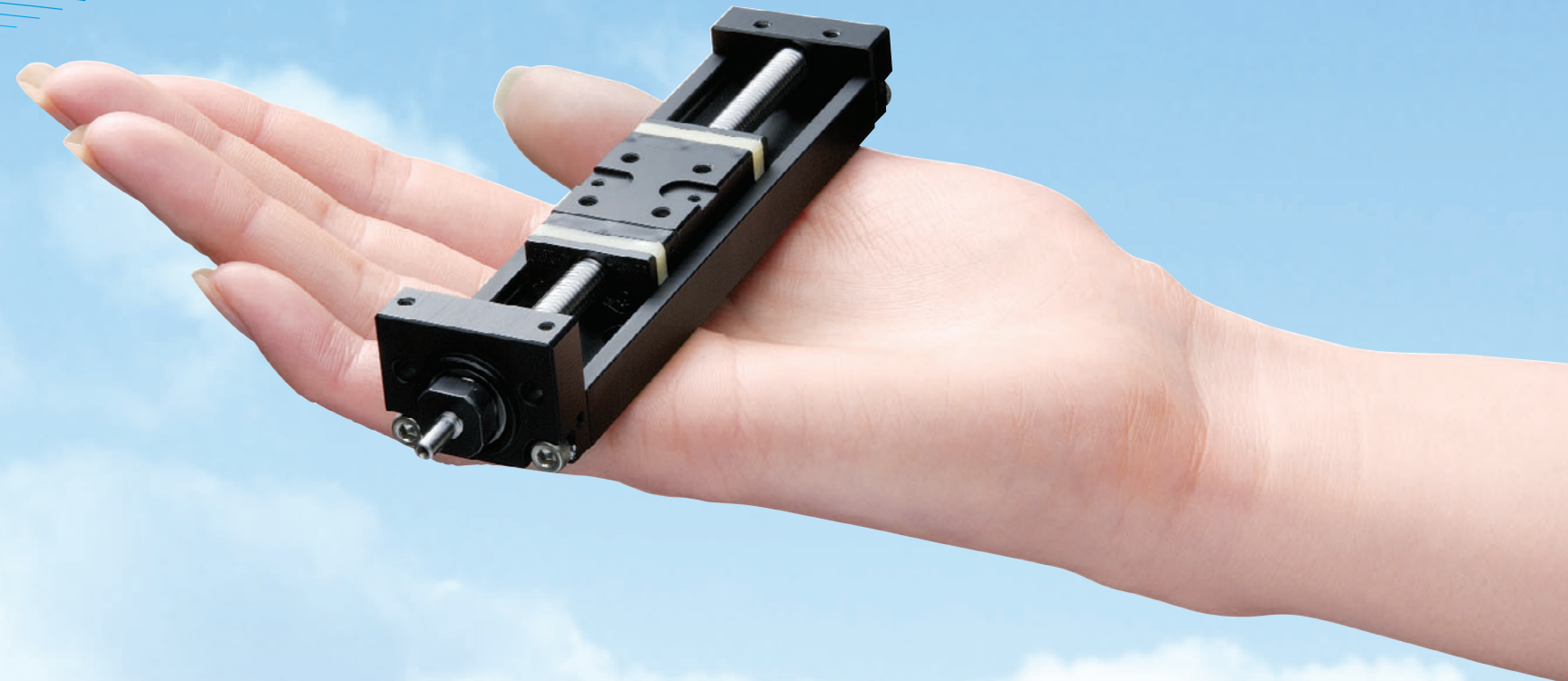

### Reference number coding

The Monocarrier reference number is composed of the main basic specifications.

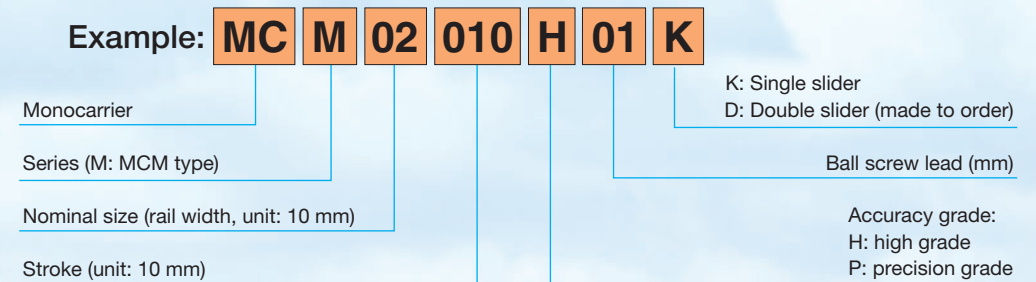

## Monocarrier rigidity

### Rail material rigidity

The Monocarrier MCM02 and MCM03 rail features a special concave shape with a small space to maintain high resistance to deflection and distortion. The geometrical moment of inertia of rail area in each direction is shown in Fig. 1.

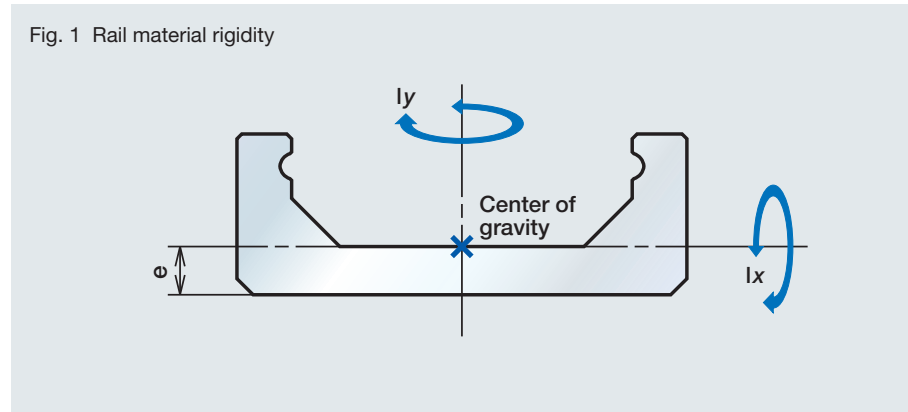

### ●Rail material rigidity

	Geometrical moment of inertia [mm <sup>4</sup> ]		Center of gravity [mm]
	lx	ly	e
MCM02	9.71×10 <sup>2</sup>	1.32×10 <sup>4</sup>	3.3
MCM03	0.30×10 <sup>4</sup>	3.30×10 <sup>4</sup>	4.5

### Rigidity in radial direction

NSK has succeeded in fully eliminating clearance of the Monocarrier's linear guide at micron-meter processing accuracy through its own high-precision processing technique. The linear guide has virtually no clearance and exhibits the load/deformation characteristics shown in Fig. 2.

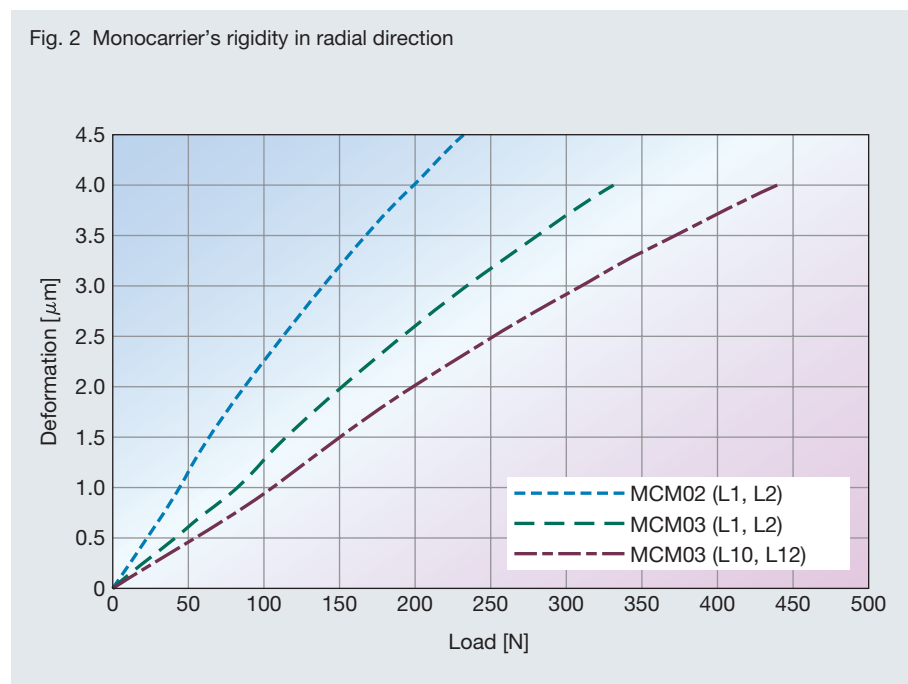

## Permissible speed

The relationship in permissible speed between rated speed and stroke is shown as follows:

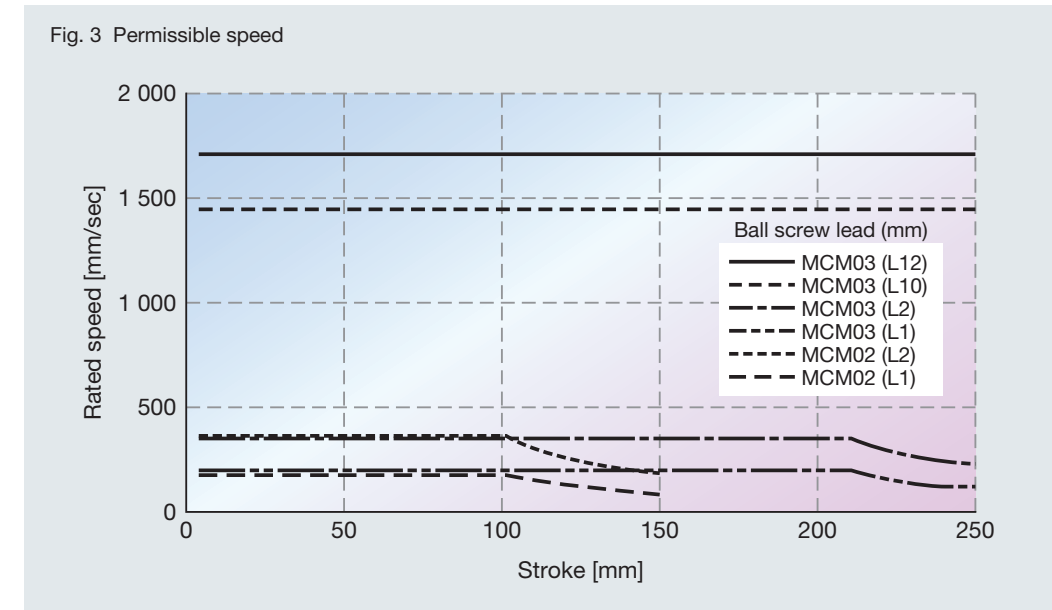

## Accuracy standard

### MCM02

unit: μm

Stroke [mm]	High grade [H]			Precision grade [P]			
	Repeatability positioning accuracy	Running parallelism (vertical)	Backlash	Repeatability positioning accuracy	Running parallelism (vertical)	Backlash	Positioning accuracy
50	±10	14	20 or less	±3	8	3 or less	20
100							
150							

### MCM03

unit: μm

Stroke [mm]	High grade [H]			Precision grade [P]			
	Repeatability positioning accuracy	Running parallelism (vertical)	Backlash	Repeatability positioning accuracy	Running parallelism (vertical)	Backlash	Positioning accuracy
50	±10	14	20 or less	±3	8	3 or less	20
100							
150							
200							
250							

## Load factor

Model numbers	MCM02		MCM03			
	1	2	1	2	10	20
ε <sub>R</sub>	95.2		79.4		79.4	
ε <sub>P</sub>	174		113.9		84.2	
ε <sub>Y</sub>	174		113.9		84.2	

## Guide for grease replenishment (for MCM02)

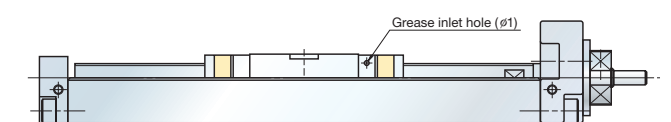

When packing grease into the unit, apply it directly to the rail groove or ball screw groove or use a grease gun or similar tool to pack it into the grease inlet hole located on the side of end cap (as shown above). Generally, the applied area must be filled with grease to the point where a small amount of supplied grease is discharged around the area surrounding the ball slide.



Monocarrier MCM02 offers optional parts as standard inventory to quickly meet any requirements.

## Cover unit

MC-CV020xx-00

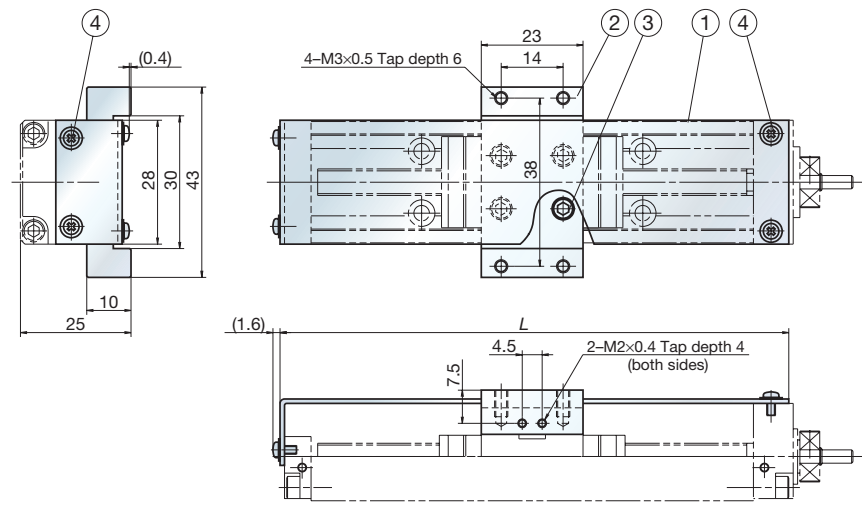

Unit: mm

No.	Part name	Quantity	Remarks
①	Top cover	1	
②	Spacer	1	
③	Hexagon socket head cap bolt	4	M3×6
④	Cross-recessed pan-head machine screw with flat washer	4	M2×4

Stroke	Reference number	L
50	MC-CV02005-00	115
100	MC-CV02010-00	165
150	MC-CV02015-00	215

## Sensor unit

MC-SR02-xx

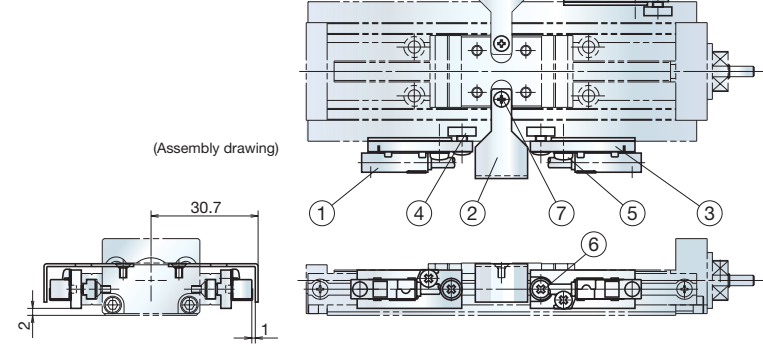

Components of sensor unit

No.	Part name	Quantity			Remarks
		MC-SR02-00	MC-SR02-01	MC-SR02-02	
①	Small proximity sensor (a-contact point)		3	1	E2S-W13: OMRON Corp.
	Small proximity sensor (b-contact point)	3		2	E2S-W14: OMRON Corp.
②	Sensor dog	2	2	2	
③	Sensor plate	3	3	3	
④	Nut for sensor	3	3	3	M3
⑤	Cross-recessed pan-head machine screw	3	3	3	M3
⑥	Cross-recessed pan-head machine screw with flat washer	3	3	3	M3
⑦	Cross-recessed countersunk head screw	2	2	2	M2

Components for sensor rail

No.	Part name	Quantity	Remarks
①	Sensor rail	1	
②	Cross-recessed pan-head machine screw	1	M2×5
③	Cross-recessed countersunk head screw	1	M2×5

Sensor rail's reference number uses its last four-digit number to indicate approximate length of the body's [L<sub>2</sub>].

## Sensor rail

MC-SRL2-xxxx

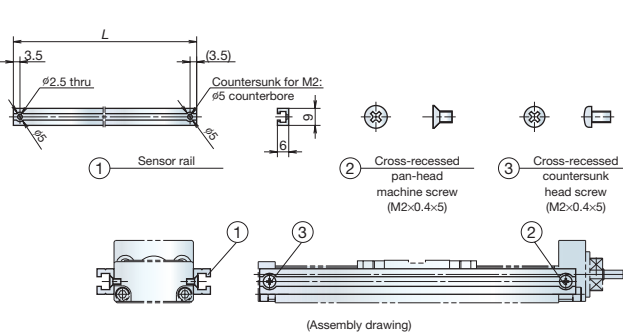

Unit: mm

Stroke	Reference number	L
50	MC-SRL2-0100	111.5
100	MC-SRL2-0150	161.5
150	MC-SRL2-0200	211.5

## Motor bracket

MC-BK02-128-00

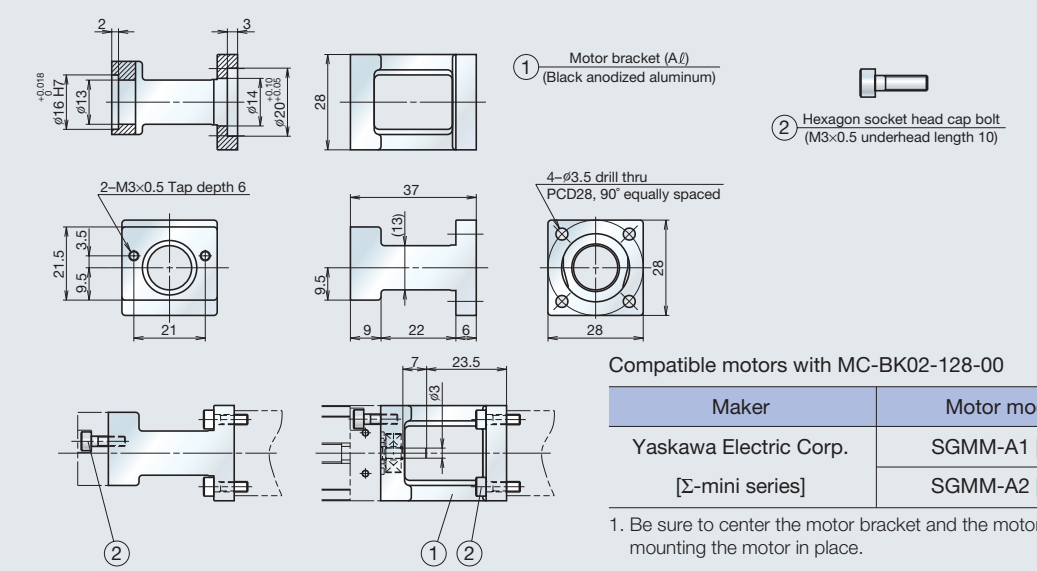

Compatible motors with MC-BK02-128-00

Maker	Motor models
Yaskawa Electric Corp. [Σ-mini series]	SGMM-A1 [10W] SGMM-A2 [20W]

1. Be sure to center the motor bracket and the motor when mounting the motor in place.

MC-BK02-133-00

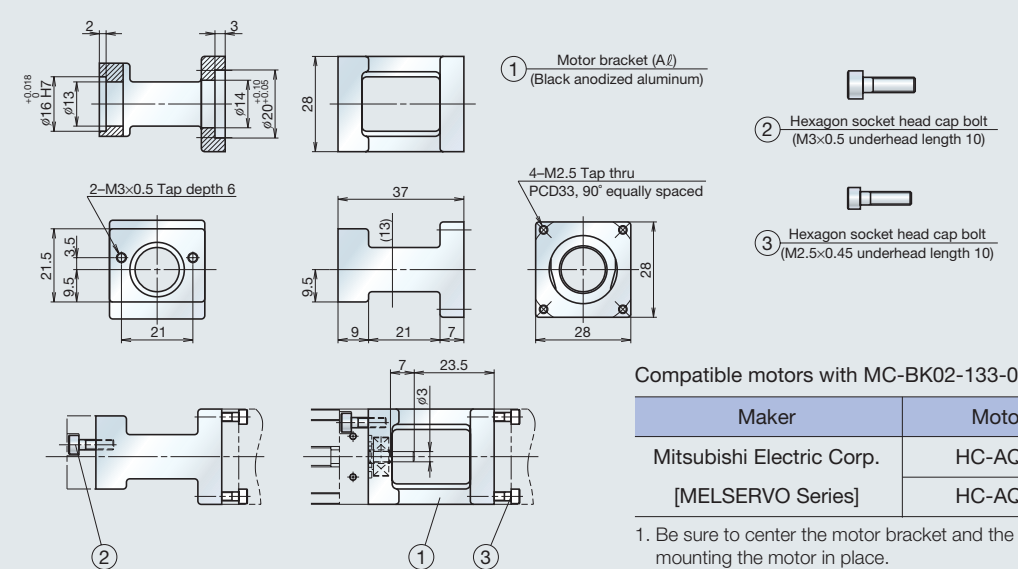

Compatible motors with MC-BK02-133-00

Maker	Motor models
Mitsubishi Electric Corp. [MELSERVO Series]	HC-AQ013 [10W] HC-AQ023 [20W]

1. Be sure to center the motor bracket and the motor when mounting the motor in place.

MC-BK02-223-00

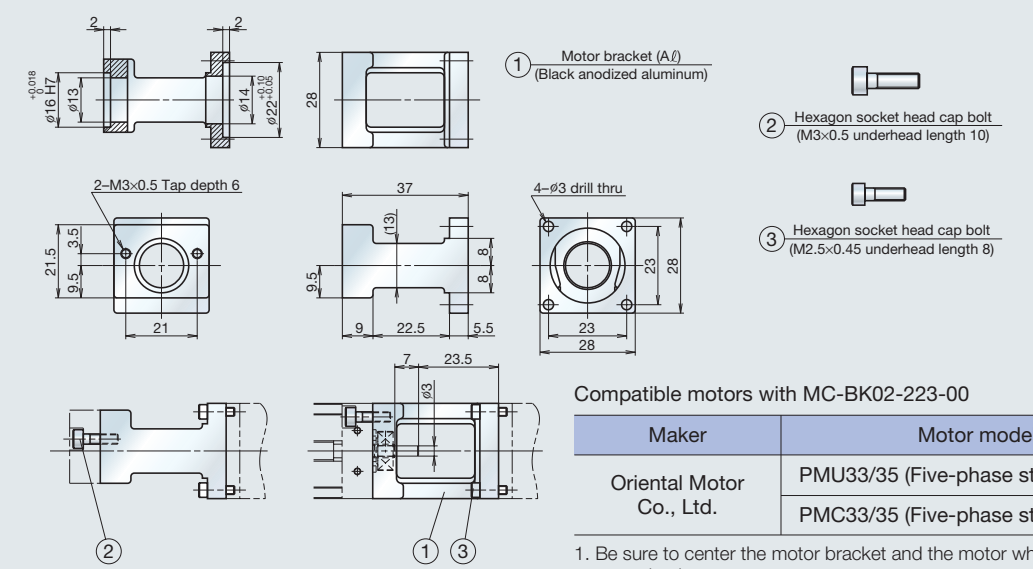

Compatible motors with MC-BK02-223-00

Maker	Motor models
Oriental Motor Co., Ltd.	PMU33/35 (Five-phase stepping motor) PMC33/35 (Five-phase stepping motor)

1. Be sure to center the motor bracket and the motor when mounting the motor in place.

