

*... an invention
prevails*



*Antifriction bearings
for circular
knitting machines*

T10E
03/04

The influence of bearings on fabric quality

There are many simple solutions of building something like a bearing. The only question is: will your customer be satisfied with the fabric quality he gets from your machine?



Franke bearing elements consist of four race rings with ground or drawn raceway and strip cage that holds the balls.



Franke bearings with ground raceways are the right solution for top quality and best cost/performance. Small mounting space and highest accuracy guarantee perfect guidance of the needles.



There are several ways ...

... of building circular knitting machines. And they all are built for only one reason: producing fabric.

It is your choice which design you prefer. And it is your choice which quality standards of your customers you will meet.

As a specialist in textile fabric you know everything about knitting machines and their design. Your customers rely on your product and on your creative potential to meet upcoming requirements in the future market of knitting machines.

To face the challenge of the future and to strengthen your current position in the market you need reliable specialists for the components your machines are build from.

We are your professional partner for antifriction wire race bearings

The bearing that rotates the dial, cylinders and fabric take-down has the biggest influence on the needle guide and therefore on the fabric that is produced. Perfect results are only achieved by accurate radial and axial guidance of the needles.

The introduction of Franke bearings as component parts has become a pioneering development in the manufacture of textile and especially circular knitting machines.

The typical feature of Franke antifriction wire race bearings are their special tempered race rings with ground or drawn raceways on which the balls run. The race rings are inserted directly into the turned grooves of the mating structure. The compact overall dimensions offer new solutions to the design of your machine that would not be attainable with any other existing bearing type.

The Franke bearing system has proved succesfull in the field of circular knitting machines for more than 50 years. More than 100 000 knitting machines all over the world are equipped with Franke bearing elements.

... and the benefit of using Franke know-how

Typical features of Franke bearing elements

There are some unique features which are significant for Franke bearing elements.

With their raceways perfectly shaped to fit the ball diameter and their ability to take loads from all directions they differ principally from the standard antifriction bearing.

Your benefit:

- High precision
- High circumferential speed
- Smallest mounting space
- Silent and smooth running
- Long lifetime
- Very cost effective
- Easy mounting

Why high precision ?

High precision is the key to high fabric quality. The guidance of the needles has significant influence on the uniformity of the fabric produced.

Franke bearing elements get their high accuracy from the special grinding process of the raceways on CNC-controlled machines which guarantee that one race ring is as perfect as the other and from the adjustability of the bearing clearance.

Standard friction bearings usually need a certain amount of clearance and an oil blanket of varying thickness between the bearing rings which inevitably cause inevitably adverse effects on the operating precision.

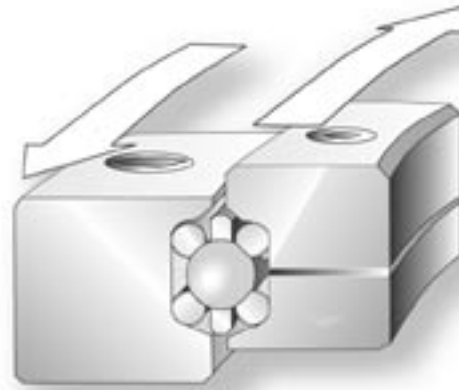

Due to the axial division of the outer respective inner ring (radial/axial bearing) with the application of Franke bearings the precise adjustability of the bearing clearance can be guaranteed.

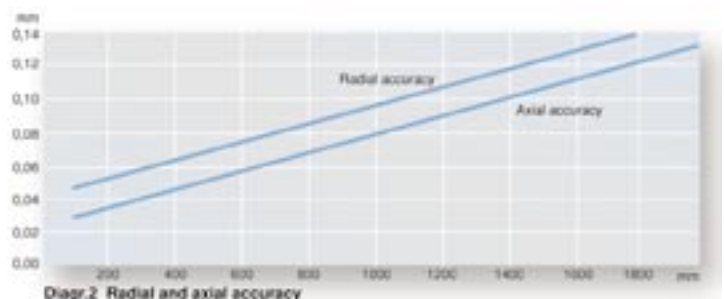



Various series - make your choice

*Bearing element
Series LEL with
ground raceways.
The high-end bearing
for perfect fabric
quality.*



There are several series ...

...of bearing elements among which you may choose. Their individual advantages may give you an idea of the technical benefit you can get out of them.

All of them supply you with the benefits of the Franke antifriction bearing system. Beside the accuracy of a bearing, the circumferential speed is very relevant.

Why high speed ?

High speed at low thermal increase becomes more and more a key feature of modern circular knitting machines. More speed corresponds directly with more production output.

In comparison with friction bearings Franke bearing elements enable you to increase the circumferential speed while reducing the driving power.

*Bearing element
Series LED with
ground or drawn
raceways. High
accuracy and load
capacity to a
favourable price.*

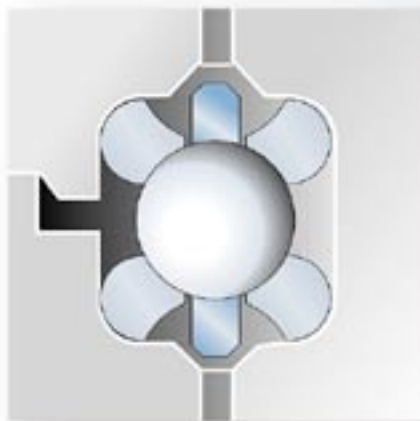

The special designed race rings and the ground surface of the raceways and the perfect guidance of the balls by the strip cage guarantee circumferential speed up to 10m/s with ease. As even at this high speed scarcely any thermal accretion is observed this has a positive influence on all other parts and factors of the operation.



*Bearing element
Series LER with
drawn raceways in
rectangular shape.
Easy machining of
the mating structure
and most compact
design.*

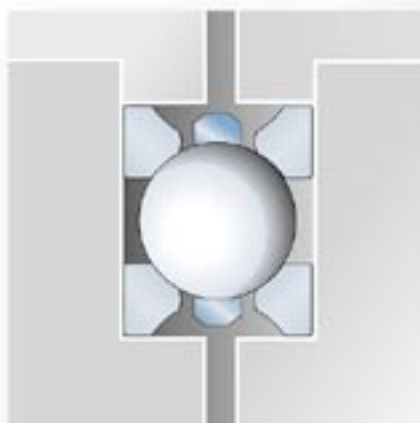

Why smallest mounting space ?

The race rings are embedded directly into the mating structure. The cross section of the bearings are very small and all you have to do is to machine the housing parts according to the shape of the race rings.

This gives you great freedom in designing the mating structure according to your individual requirements. Even the housing material that you use is your own choice.

... and participate from our experience

Why light and smooth running ?

In comparison to traditional friction bearings Franke bearing elements allow cylinders to be started and stopped in a uniform and jerky-free motion. This is essential concerning loop structure and needle wear.

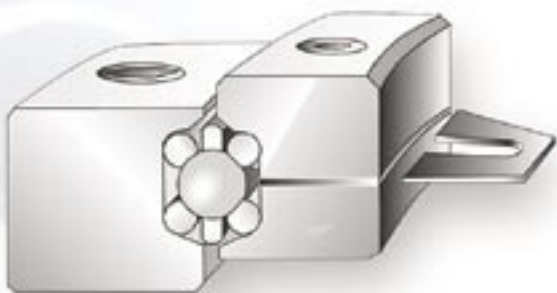

Depending on the high accuracy of the raceways and the adjustability of clearance Franke bearing elements can be accelerated and decelerated without building up vibrations. Washers (shims) can be used to adjust the defined preload for a perfect result in stiffness and smooth running.

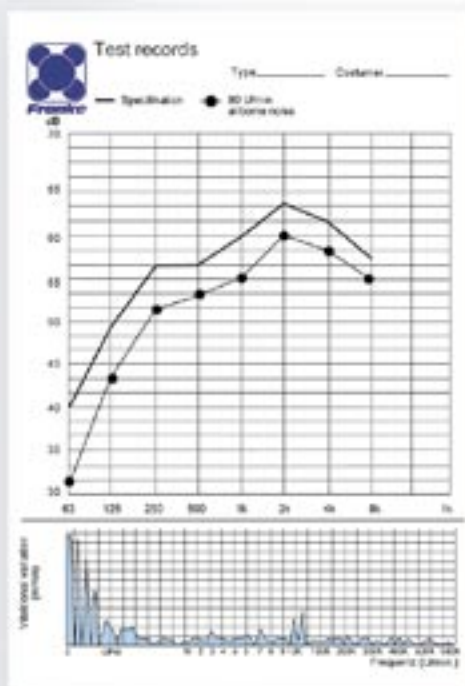

Why long lifetime ?

Tempered steel and the Franke high-precision grinding technology guarantee a long lifetime of the bearing parts.

Due to the 4-point-contact design which enables the bearing to take equal loads from all directions, Franke bearing elements are perfectly suited to carry loads for a long lifetime. If the bearing, however, should lose its preload it can be easily re-adjusted.

If necessary single parts like race rings or strip cages are available as spare parts and can be renewed without replacing the whole bearing.

Participate from 50 years of Franke bearing experience!

Why easy mounting ?

Depending on correct machining of the mating structure the mounting of Franke bearing elements is easy and quick.

The required preload can be adjusted and re-adjusted at any time by using washers (shims).

Why cost-effective ?

The question of price very often is of primary importance. Compared to standard bearing solutions the Franke bearing system is very cost-effective due to several reasons:

1. The high precision running of the Franke bearing reduces the drive power by 30%. That means that you can calculate with much smaller motor power rating.
2. The vibrationless operation of Franke bearings saves the lifetime of all parts involved in operation. The machines are running longer, faster, more silently and without mechanical break-downs.
3. Low thermal increase enables the machines to rotate in high speed for longer hours. The production output is increased.
4. Franke bearings are running for long periods without any maintenance thus saving time and money.
5. The prices for Franke bearings are in a perfect cost-performance ratio. For volume requirements and large numbers of bearings we offer special volume prices.



Technical Details

Series LEL

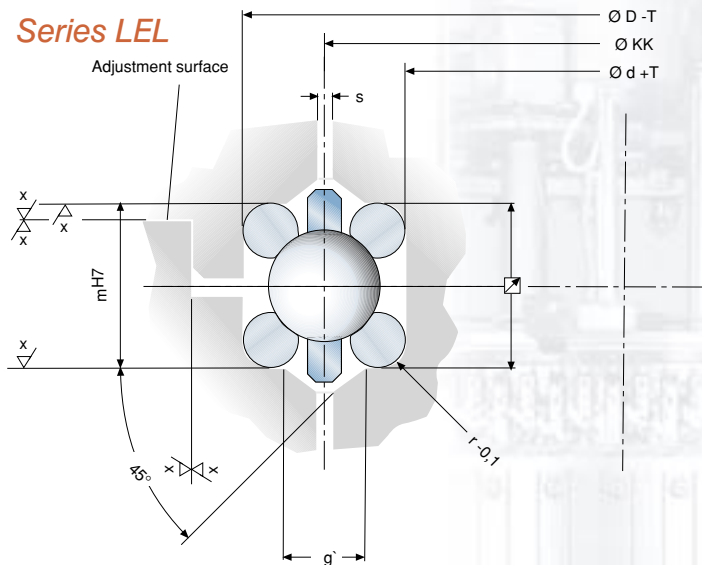

Bearing elements consisting of:

4 race rings with ground raceways,
1 strip cage with retained balls

Perfectly suited for highest accuracy and load capacity

Ball \varnothing	KK \varnothing	Wire \varnothing	enclosing square	r
8	70 - 790	4	12,00	1,9
9,525	300 - 1180	4	12,95	1,9
12,000	800 - 1500	4	14,61	1,9

Dimensions [mm]

Series LED

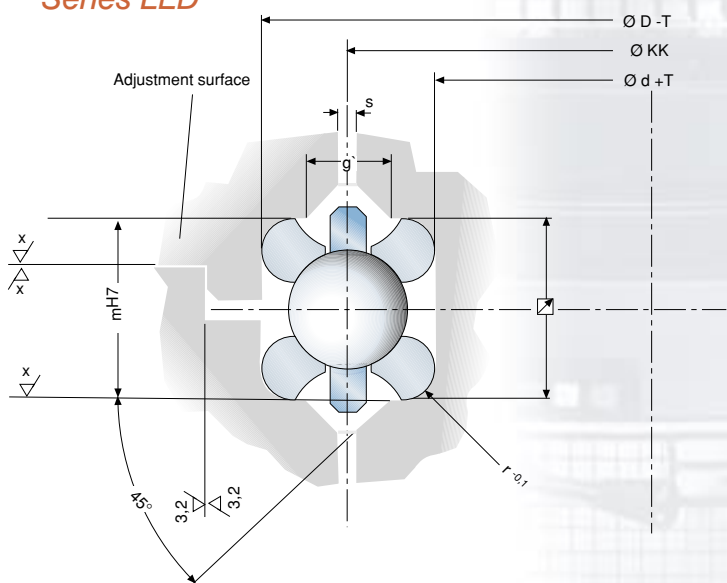

Bearing elements consisting of:

4 profiled race rings with ground or drawn raceways
1 strip cage with retained balls

Profiled race rings especially with drawn raceways are very cost-effective. Accuracy and load capacity are slightly lower than with series LEL.

The perfect solution for medium loads and accuracy

Ball \varnothing	KK \varnothing	Wire \varnothing	enclosing square	r
9,525	70 - 1500	4	12,86	1,9
12,000	800 - 1500	4	14,61	1,9

Dimensions [mm]

Series LER

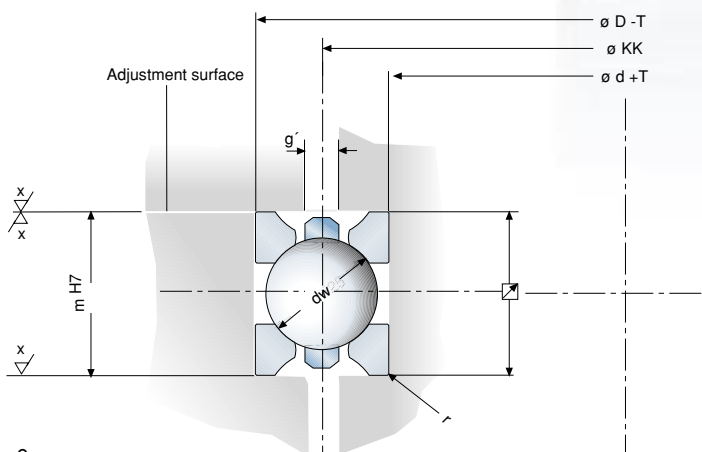

Bearing elements consisting of:

4 rectangular profiled race rings with drawn raceways,
1 strip cage with retained balls

Due to the rectangular profile of the race rings the machining of the mating structure is very simple. The drawn raceways are shaped according to the ball diameter.

The first choice when the price is the limiting factor. Medium accuracy and load capacity.

Ball \varnothing	KK \varnothing	Wire \varnothing	enclosing square	r _{max.}
9,525	70 - 1500	4 x 3	13 x 11	0,3

Dimensions [mm]

... that will convince you

Material, Accuracy

	Ball race ring	Balls	Strip cages
Standard	54SiCr6	100Cr6	PA12
Special	X12CrNi177 X7CrNiAl177 Duratherm	X45Cr13 Oxidkeramik POM	Niro Bronze Brass Hard plastics

Tab.1 Material

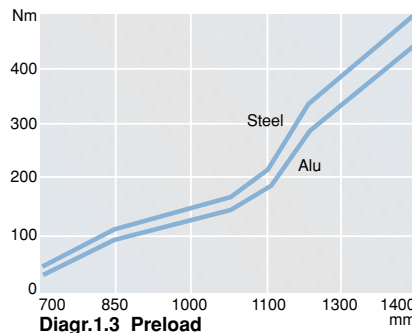
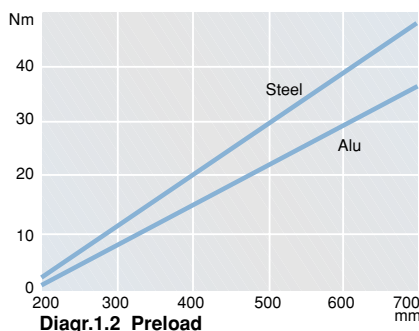

Operating temperature -40C up to +100C
 Circumferential speed 12 m/s
 oil lubrication 10 m/s
 grease lubrication 10 m/s

In addition we supply:

- antifriction wire race bearings in any diameter size from 70 - 1500 mm
- special strip cages for textile machinery
- individual solutions for your application

Accessories

Strip cages

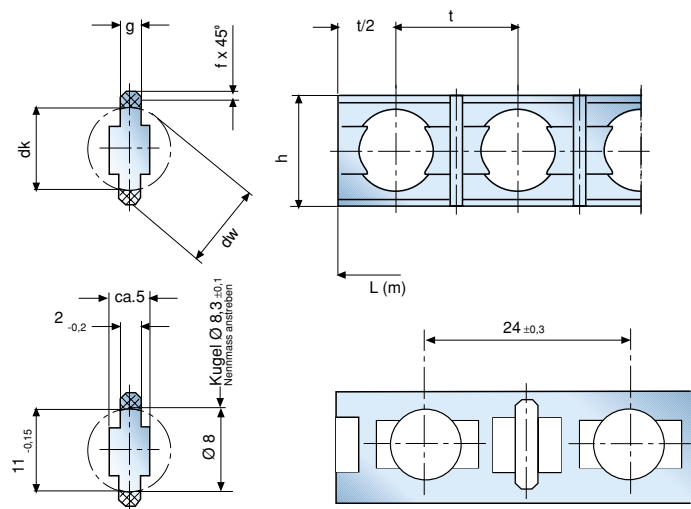

Cage Size	dw mm	Zoll	h	g	t	f
LKB8	8,0	5/16	10,6	2,0	12,0	0,6
LKB9,5	9,5	3/8	12,6	2,5	14,0	0,7
LKB12	12,0		15,0	2,5	16,0	0,7

Dimensions [mm]

Strip cage series **LKB08C** for circular knitting machines.

This special designed strip cage meet the requirements of modern knitting machines such as high speed and low thermal accruement

Washers

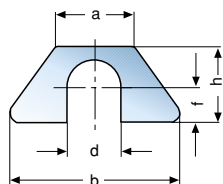

Size	a	b	d	f	h
M6	11,0	24,4	7	5	11,0
M8	14,7	34,2	9	6	13,5
M10	16,4	42,3	11	7	16,0
M12	20,3	46,0	13	8	18,0
M16	25,4	54,0	17	11	24,0

Dimensions [mm]



Satellite technology



X-ray apparatus



Hair dressing sink



Car industry



Cutting machine

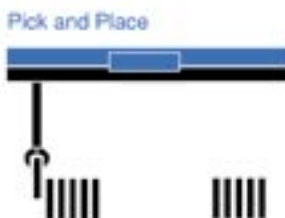

Pick and Place



Portal robot



Circular knitting machine



Packing machine



Industrial rotary table



Tool changer

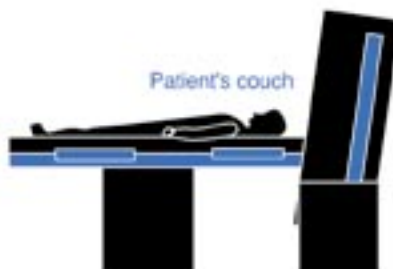

Patient's couch



Laser cutting



Deep-well drilling installation



Lifting device



Stirring



Measuring and testing



Medical care

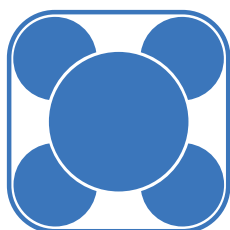

Franke GmbH
Postfach 1280, D-73402 Aalen
Obere Bahnstr. 64, D-73431 Aalen
Telefon 07361 / 920-0
Telefax 07361 / 920-120
e-mail: info@franke-gmbh.de
www.franke-gmbh.com