



## SLIDE WAY NV type/NVT type

### *STUDROLLER system* (Rivet Roller Structure)

The **STUDROLLER** system is based on a new concept to provide complete prevention of roller-cage slippage during operation. This system permits usage in all orientations and accommodates extremely high acceleration and deceleration.

The number of effective rollers has been increased to a maximum of 18!

The contact length between the rollers and the raceway surface has been extended 30 to 58%!

When compared with conventional SV types, this increases the load rating from 1.3 to 2.5 times!

Therefore:

Size Reduction



Space Saving



Reduced Cost!

(Compared to conventional SV type)

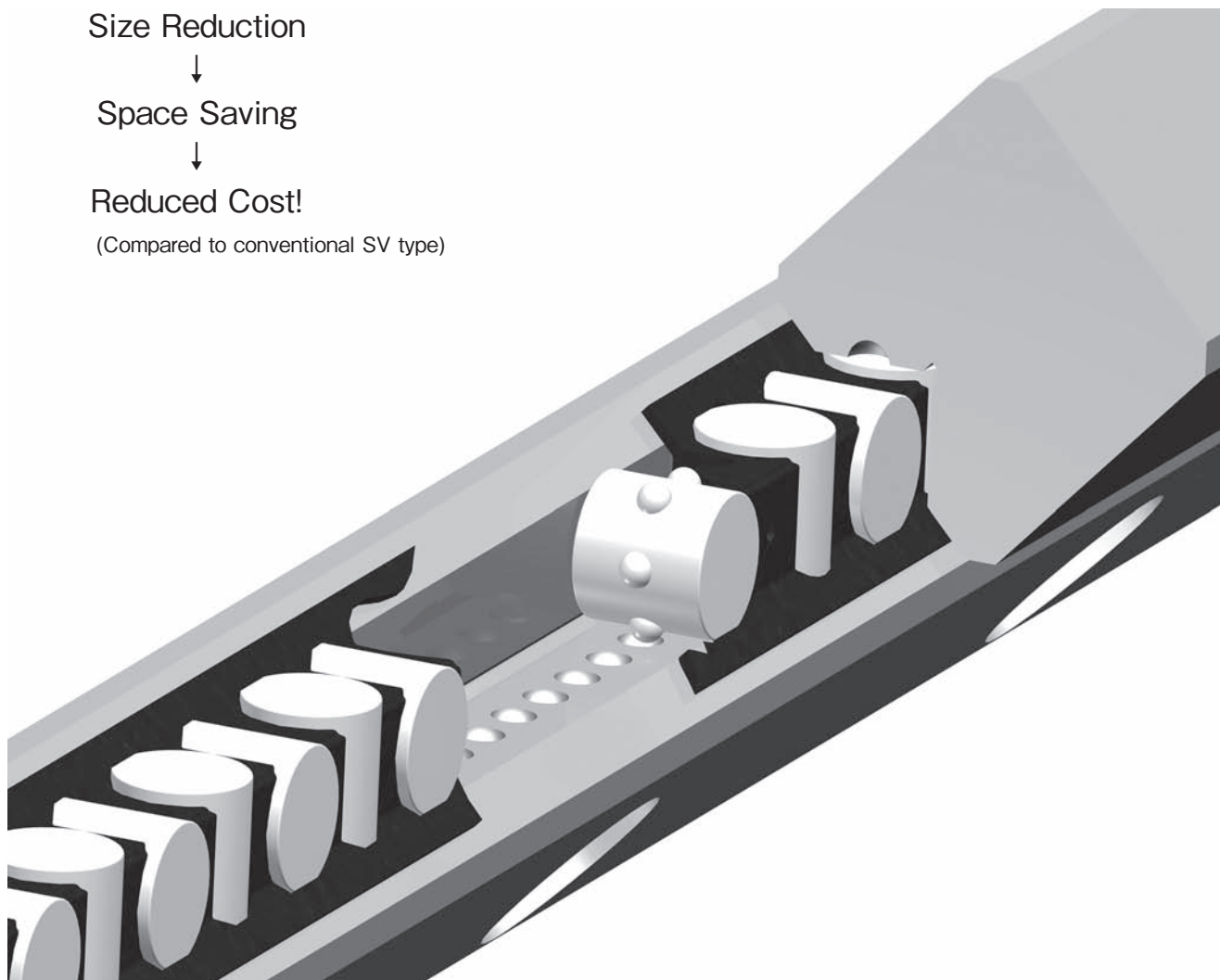

NB's Slide Way NV and NVT type bearings incorporate **STUDROLLER**, which has been developed based upon a new concept. This next-generation, linear-motion bearings possess smoothness and high accuracy afforded by completely eliminating slippage between the rollers and the raceway surface.

## STRUCTURE AND FEATURES

NB's Slide Way NV and NVT types comprise precisely ground rails and R-retainers with built-in **STUDROLLERS**. The rails have been optimally designed so that the **STUDROLLERS** move smoothly, and the **STUDROLLERS** and precision rollers incorporated in the R-retainers enable slip-free operation between the raceway surface and the rollers resulting in motion with minimal frictional resistance.

### Non-slip **STUDROLLER** System

The newly-conceived, built-in **STUDROLLER** system completely eliminates slippage inside the product and permits usage in all orientations, and accommodates extremely high acceleration and deceleration.

### Compatibility with Conventional Types

The same dimensions as the Slide Way SV type enable complete compatibility between the two series.

### Smooth Movement

The optimum design of the roller raceway and the (resin) R-retainers provides a quiet and smooth movement.

This design also results in less lubrication spray than the Slide Way SV type.

### High Rigidity, High Load Capacity

Based on the new rail design, the contact length of the rollers and raceway surface is increased by 30 to 58%, and increasing the number of rollers by narrowing the roller pitch allows a load rating that is 1.3 to 2.5 times greater (compared to the conventional SV type).

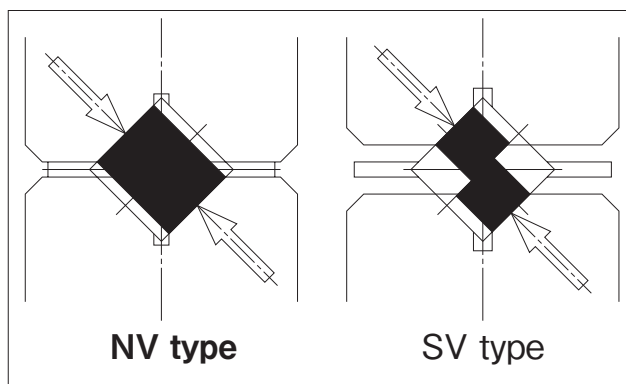
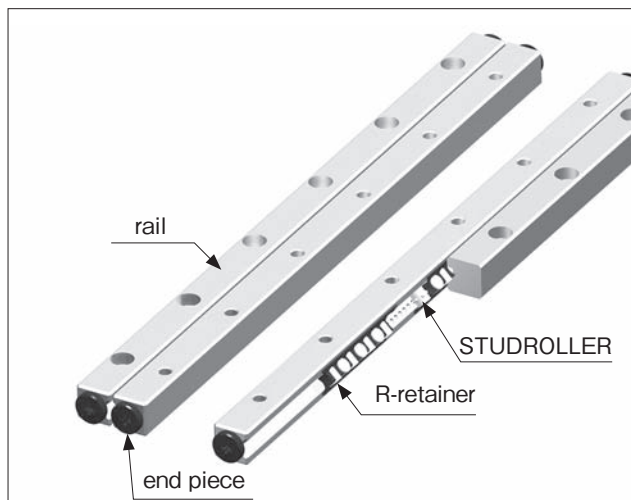
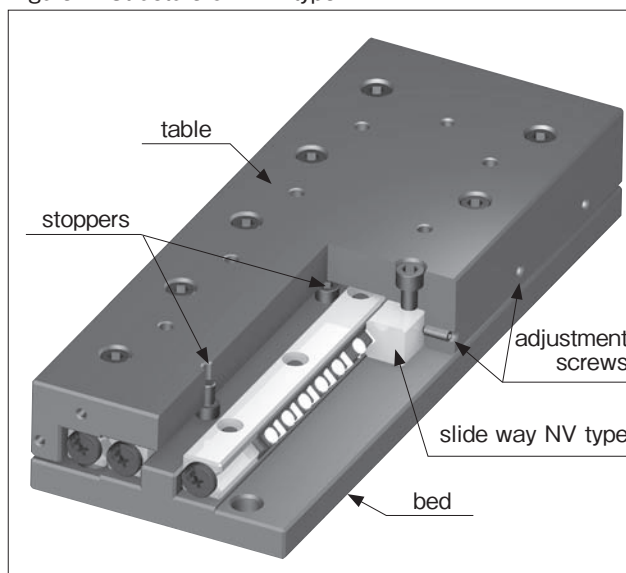

Figure 2. Structure of NVT type

Figure 1. Structure of NV type



\* In the NV type, a fastening plate is attached for the purpose of maintaining the center position of the R-retainer before assembly. Please see Installation Procedure on Page 5 and remove the fastening plate before use.





## TYPE

### NV type

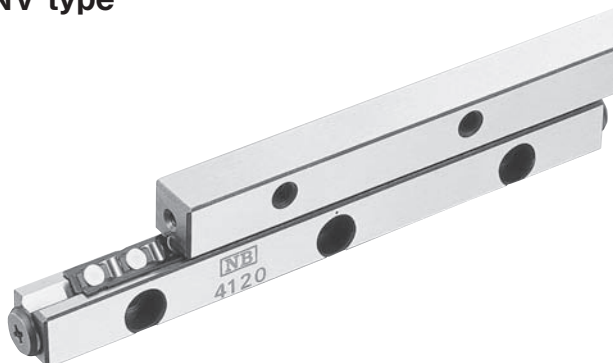

### NV type

This product comprises a set of four rails, two R-retainers, and eight end pieces. It permits flexible design of the table which allows it to be used in a way that will best suit your application.

### NVT type

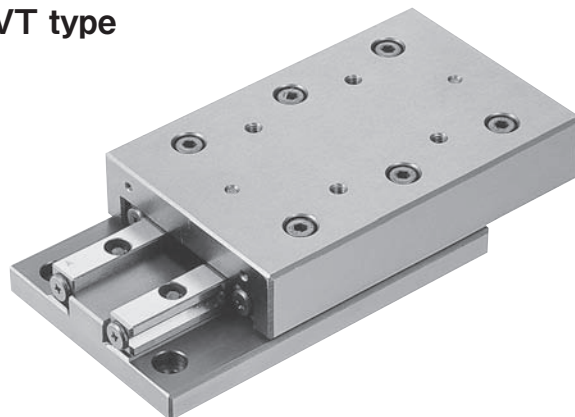

### NVT type

This is a slide table that incorporates the NV type. The table and bed have been precision machined to provide a high degree of accuracy and the product can be used as received, without any need whatsoever for troublesome accuracy or preload adjustments.

## ACCURACY

### NV type

The accuracy of the Slide Way NV type is represented as parallelism measured across the full length with a method such as shown in Figure 4. It is classified as High (no symbol), Precision (P), or Ultra Precision (UP). Special accuracies can also be accommodated. Please contact NB for details.

Figure 3. Parallelism

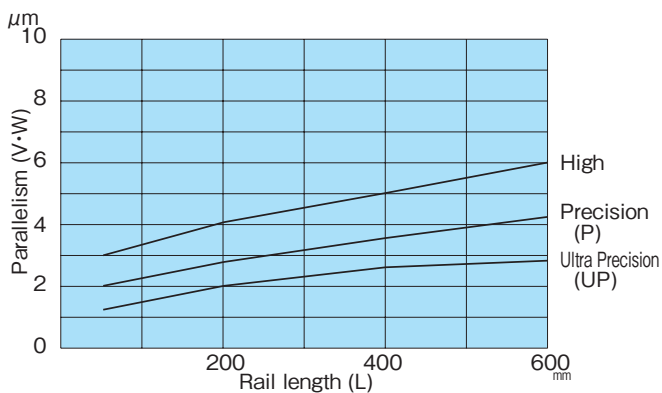

### NVT type

The motion accuracy of the slide table NVT type is expressed as deviation on the dial indicators attached to the center of the top and side of the table, when the table is moved back and forth without load.

Figure 4. NV type Accuracy Measurement

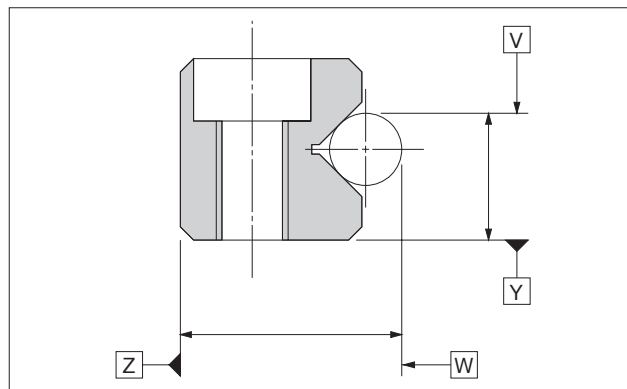
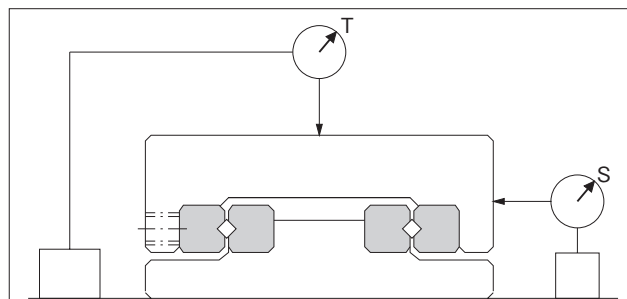

Figure 5. NVT type Accuracy Measurement



## LOAD RATING

The load rating of the Slide Way NV and NVT types differs depending on the direction of the load.

Table 1. Change of Load Rating Corresponding to Load Direction

Basic dynamic load rating	Normal vertical direction	1.0 × C
	Horizontal direction	0.85 × C
	Reverse vertical direction	0.7 × C
Basic static load rating	Normal vertical direction	1.0 × Co
	Horizontal direction	0.85 × Co
	Reverse vertical direction	0.7 × Co

\* There may be a difference depending on size. Please contact NB for details.

Consideration has been given to holes for STUDROLLERS in the raceway surface, and the load rating in each direction has been determined.

## RATED LIFE

The life of the Slide Way or the Slide Table is calculated with the following equations:

Rated Life

$$L = \left( \frac{1}{f_w} \cdot \frac{C}{P} \right)^{\frac{10}{3}} \cdot 50$$

L: rated life (km) fw: load coefficient C: basic dynamic load rating (N) P: load (N)

### Load Coefficient fw

When calculating the load operating on the Slide Way, in addition to the mass of the object it is necessary to obtain the correct values of many factors including inertial force, and moment, caused by motion speed with various temporal changes. However, linear stroke motion is always accompanied by a repetition of starting and stopping, and there are also uncertain elements such as vibration and impact. This is why correct

## LUBRICATION AND DUST PREVENTION

### Lubrication

The Slide Way is pre-lubricated with lithium soap-based grease prior to shipment and is therefore ready for immediate use. Make sure to lubricate with a similar type of grease periodically according to the operating conditions.

NB also provides grease for low-dust linear systems. Please contact NB for details.

### Dust Prevention

When dirt or dust enters the Slide Way, the accuracy and service life may deteriorate. Therefore, when used in a harsh environment,

Figure 6. Direction of Load

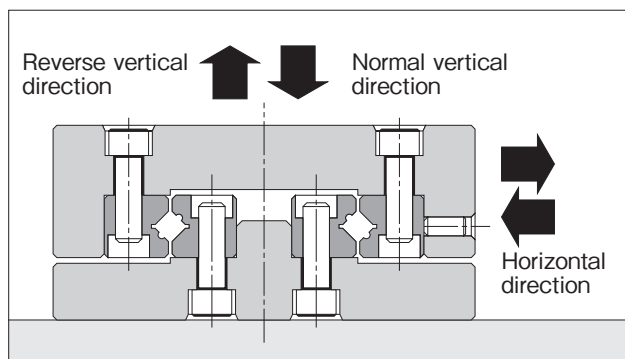

Life Time

$$L_h = \frac{L \cdot 10^3}{2 \cdot \ell_s \cdot n_1 \cdot 60}$$

Lh: life time (hours) ℓs: stroke (m) n1: Number of cycles per minute (cpm)

load calculation is difficult. Generally, the load coefficient fw shown in Table 2 is used to simplify the calculation of life.

Table 2. Load Coefficient fw

Operating condition		Load coefficient fw
Load	Speed	
No impact / vibration	15m/min or less	1.0 to 1.5
Low impact / vibration	60m/min or less	1.5 to 2.0
High impact / vibration	60m/min or more	2.0 to 3.5

please protect the Slide Way by providing outside protective covers. (Figure 7)

Figure 7. Example of Dust Prevention Mechanism

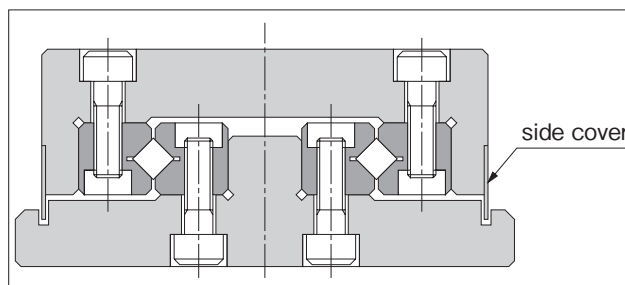



## MOUNTING NV TYPE

### Accuracy of the mounting surface

To maximize the performance of the NB Slide Way, it is recommended that the precision of the mounting surface be finished to be equal to or greater than the degree of parallelism of the Slide Way.

- Parallelism of surface 1 against surface A
- Perpendicularity of surface 2 against surface A
- Parallelism of surface 3 against surface B
- Perpendicularity of surface 4 against surface B
- Parallelism of surface 2 against surface C
- Parallelism of surface 4 against surface C

### Installation Procedure

Note: \* Provide external mechanical stoppers.  
 \* Set the movement to be less than the specified stroke.

- (1) Remove burrs, scratches, and dust from the rail mounting surface of the table and bed, and be careful to prevent contamination during assembly.
- (2) Apply low-viscosity oil to the contact surfaces, and align the table and the bed. (Figure 10a)
- (3) Set the reference surface shown in Figure 4 onto the mounting surface with the rails assembled. Set the table in the center position, and tighten the adjustment screws lightly so that almost no gap remains. (Figure 10b)
- (4) Keep the table in the center, tighten the rail mounting bolts lightly, loosen the end pieces of both end faces, and remove the fastening plate. Following this, firmly retighten the end pieces.
- (5) While maintaining the conditions of (4), gently move the assembly through its stroke being certain to check that the specified stroke length has been secured, and that there is no problem with the operation, or any other irregularity.
- (6) Move the table to the center and tighten only the adjustment screws on the R-retainer with the recommended tightening torque as shown in Table 3. (Figure 10c)
- (7) Gently move the table to one stroke end, and check that the table has surely come into contact with the external mechanical stopper. Following this, tighten the adjustment screws on the R-retainer in the same manner as (6). (Figure 10d)
- (8) Move the table to the opposite stroke end, and tighten in the same manner as (6). (Figure 10e)
- (9) Fasten the mounting bolts on rails 1, 2, and 3 by tightening with the recommended torque shown in Table 4. (Figure 10f)
- (10) Set the dial indicators to the center of the table and to the side (reference surface) of the table. (Figure 10g)
- (11) Perform the final preload adjustment. While moving the table back and forth, repeat steps (6) and (7) until the dial indicators show a minimum deviation.
- (12) Finally, securely fasten rail 4, which has been provisionally mounted, using the recommended torque. As with the adjustment screws, successively tighten the mounting bolts on the R-retainer while moving the table.

Figure 8. Accuracy of Mounting Surface

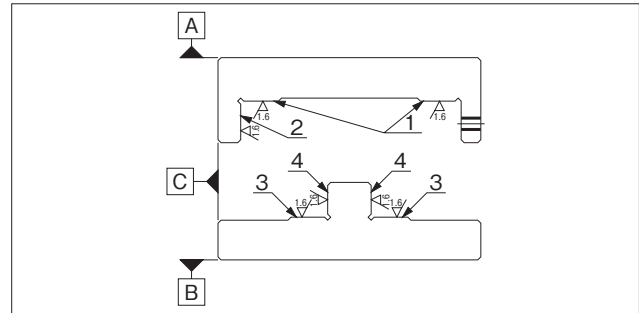

Figure 9. Example of Mounting

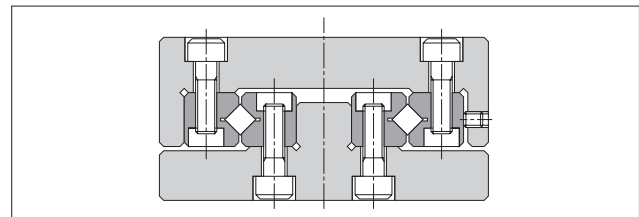

Figure 10. Installation Method

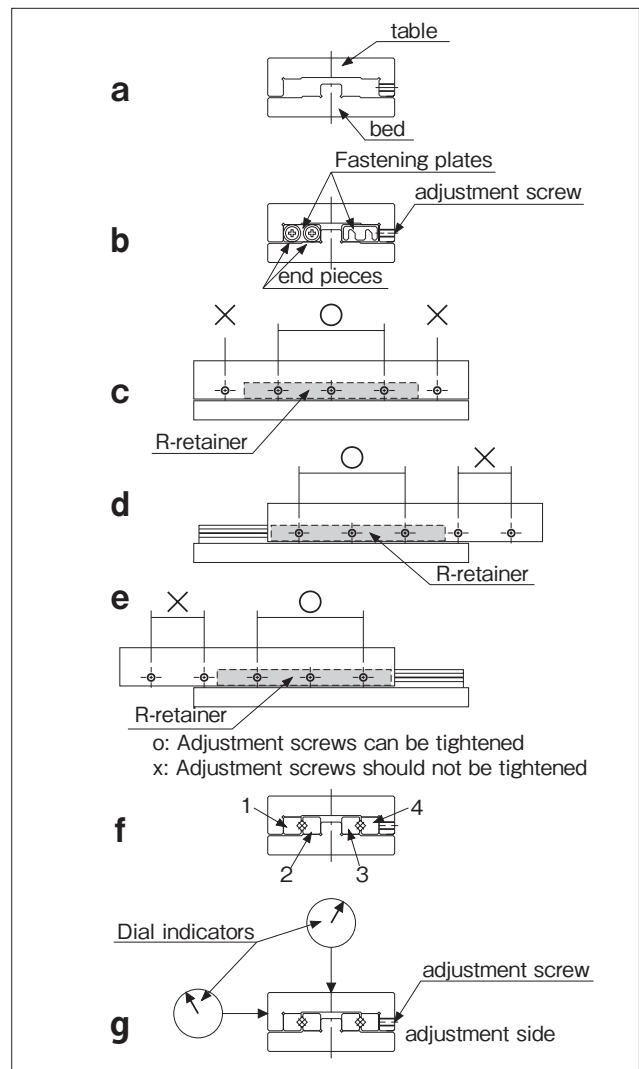

Table 3. Recommended Torque for Adjustment Screws Unit/N·m

Part number	Size of screws	Torque
NV2	M3	0.012
NV3	M4	0.05
NV4	M4	0.08
NV6	M5	0.20
NV9	M6	0.40

Table 4. Recommended Torque for Mounting Bolts Unit/N·m

Size of screws	Torque
M3	1.4
M4	3.2
M5	6.6
M6	11.2
M8	27.6

(When using steel alloy bolts)

## SPECIAL MOUNTING BOLT BT TYPE

To mount the Slide Way using its counter bore, use of the BT type of special mounting bolt is recommended.

Figure 11. Special Mounting Bolt

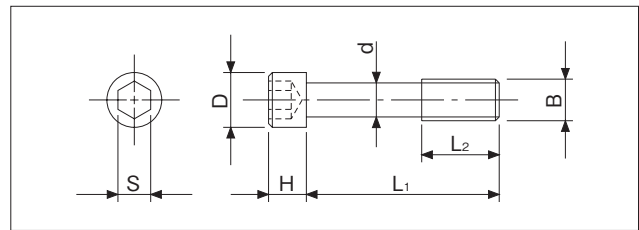

Table 5. Special Mounting Bolt

Part number	B	d mm	D mm	H mm	L <sub>1</sub> mm	L <sub>2</sub> mm	S mm	Applicable track rail
BT 3	M3	2.3	5	3	12	5	2.5	NV 3
BT 4	M4	3.1	5.8	4	15	7	3	NV 4
BT 6	M5	3.9	8	5	20	8	4	NV 6
BT 9	M6	4.6	8.5	6	30	12	5	NV 9
BT12	M8	6.25	11.3	8	40	17	6	NV12

## PRECAUTIONS FOR USE

### Careful Handling:

The NV type is packaged as a set of rails and R-retainers. Do not separate or disassemble until assembly/installation is completed. Dropping this product may cause the rolling elements to make dents in the raceway surface. This will prevent smooth motion and will also affect accuracy. Be sure to handle the product with care.

### Stopper:

Exceeding the specified stroke (over-stroke) may cause the raceway surface of the rail to be damaged and the performance of the **STUDROLLER** to drastically deteriorate. Be sure to provide external mechanical stoppers and use the product within the specified allowable stroke.

### Adjustment:

Using the product with insufficient accuracy of the mounting surface or before adjusting the preload will cause the motion accuracy of the product to drop and will have a negative influence upon product life and accuracy. Make sure to assemble, install, and adjust the product with care.

### Use as a Set:

The accuracy of the rails has been matched within each set. Note that the accuracy may be affected when the rails of different sets are combined.

### Operating Temperature:

The product uses resin parts. Avoid using the product in high temperatures; use the product in environments that are lower than 80° C.

### Adjustment Screws:

The accuracy and preload of the NVT type Slide Table has been factory-adjusted to the optimal level. Do not touch the adjustment and rail mounting screws.

### Allowable Load:

The allowable load is the load under which the sum of the elastic deformation of the roller elements and the raceway surface is small on a contact portion where the contact stress of the rolling elements and the rail surface is a maximum, permitting a smooth rolling motion.

### Fastening Plates:

In the NV type, fastening plates are attached at both end faces of the rails to maintain the R-retainer center position prior to assembly. The fastening plates are not required when the NV type is used mounted to a table, bed, or the like; however, when removal of the NV type is necessary such as when it will be reassembled, be sure to return the R-retainer to the proper center position, secure the fastening plates with the end pieces, and then remove the NV type.



# NV TYPE

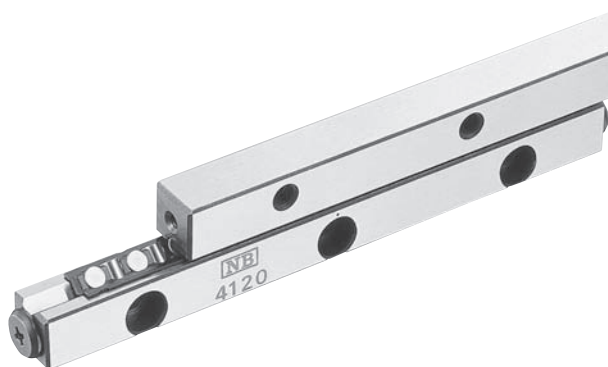
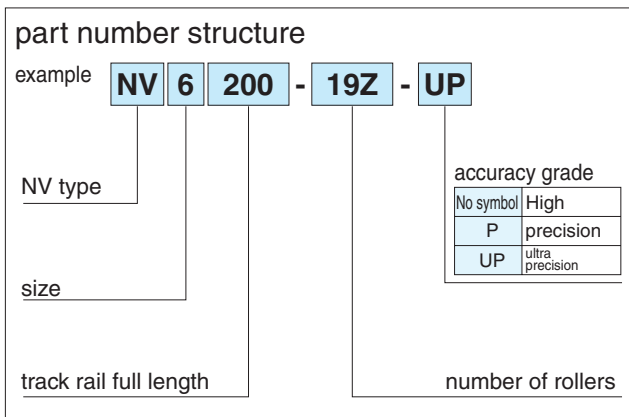

part number	stroke ST mm	roller diameter D mm	number of rollers Z	L	A	B	C	M × P	N
				mm	mm	mm	mm	mm	mm
<b>NV2030- 5Z</b>	18	2	5	30	12	6	5.7	1 × 15	7.5
<b>NV2045- 9Z</b>	25		9	45				2 × 15	
<b>NV2060-15Z</b>	30		15	60				3 × 15	
<b>NV2075-19Z</b>	40		19	75				4 × 15	
<b>NV2090-23Z</b>	50		23	90				5 × 15	
<b>NV2105-27Z</b>	65		27	105				6 × 15	
<b>NV2120-33Z</b>	70		33	120				7 × 15	
<b>NV2135-37Z</b>	80		37	135				8 × 15	
<b>NV2150-41Z</b>	90		41	150				9 × 15	
<b>NV2165-47Z</b>	95		47	165				10 × 15	
<b>NV2180-51Z</b>	100		51	180				11 × 15	
<b>NV3050- 9Z</b>	25	3	9	50	18	8	8.65	1 × 25	12.5
<b>NV3075-13Z</b>	48		13	75				2 × 25	
<b>NV3100-19Z</b>	60		19	100				3 × 25	
<b>NV3125-23Z</b>	83		23	125				4 × 25	
<b>NV3150-29Z</b>	90		29	150				5 × 25	
<b>NV3175-35Z</b>	103		35	175				6 × 25	
<b>NV3200-41Z</b>	113		41	200				7 × 25	
<b>NV3225-43Z</b>	150		43	225				8 × 25	
<b>NV4080- 9Z</b>	60		4	9				80	
<b>NV4120-17Z</b>	75	17		120	2 × 40				
<b>NV4160-23Z</b>	105	23		160	3 × 40				
<b>NV4200-29Z</b>	130	29		200	4 × 40				
<b>NV4240-37Z</b>	143	37		240	5 × 40				
<b>NV4280-43Z</b>	170	43		280	6 × 40				

The basic static load rating is the value at the center of the stroke.

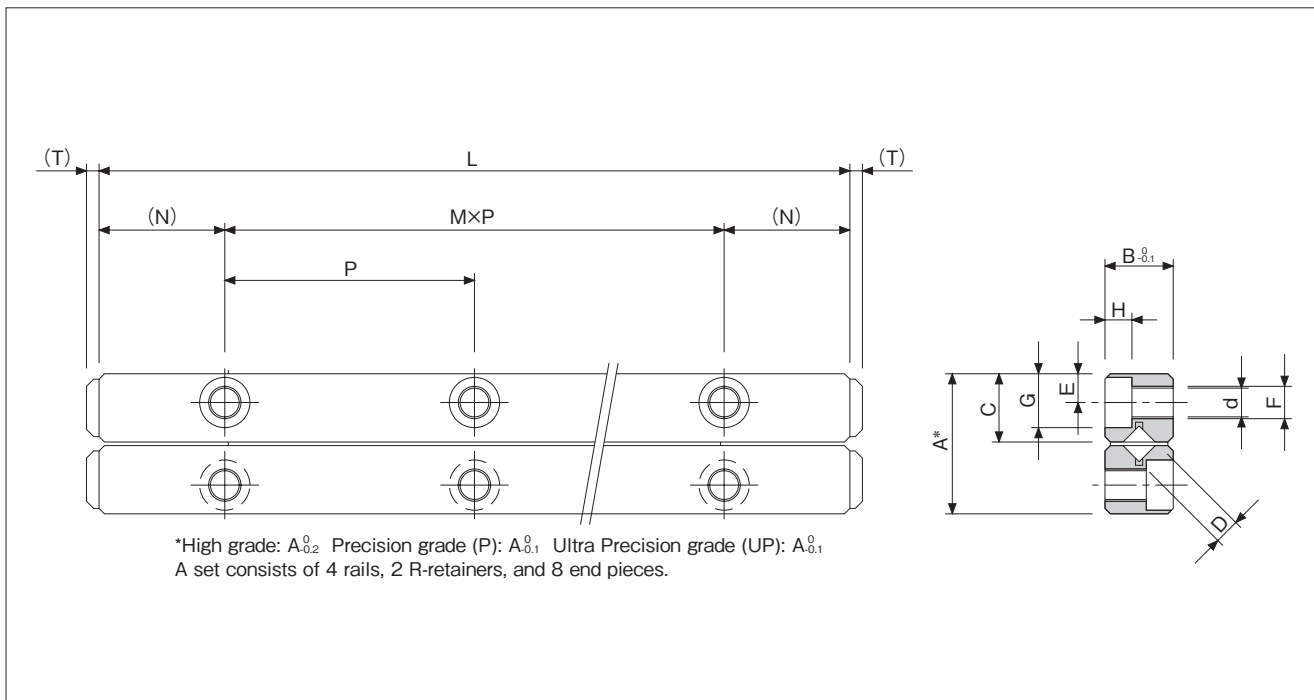

major dimensions						basic load rating		allowable load F N	mass g	size
E mm	F	d mm	G mm	H mm	T mm	dynamic C N	static Co N			
2.5	M3	2.55	4.4	2	2	1,360	1,520	500	33	<b>2030</b>
						2,330	3,050	1,010	49	<b>2045</b>
						3,990	6,110	2,030	62	<b>2060</b>
						4,740	7,630	2,540	74	<b>2075</b>
						5,460	9,160	3,050	91	<b>2090</b>
						6,160	10,600	3,560	103	<b>2105</b>
						6,830	12,200	4,070	120	<b>2120</b>
						7,490	13,700	4,580	132	<b>2135</b>
						8,130	15,200	5,090	149	<b>2150</b>
						9,370	18,300	6,110	161	<b>2165</b>
9,970	19,800	6,620	174	<b>2180</b>						
3.5	M4	3.3	6	3.1	2	6,150	8,060	2,680	97	<b>3050</b>
						8,440	12,100	4,030	140	<b>3075</b>
						12,500	20,100	6,720	192	<b>3100</b>
						14,400	24,200	8,060	245	<b>3125</b>
						16,300	28,200	9,410	290	<b>3150</b>
						19,800	36,300	12,100	337	<b>3175</b>
						21,500	40,300	13,400	385	<b>3200</b>
						23,200	44,300	14,700	434	<b>3225</b>
4.5	M5	4.3	8	4.2	2	12,100	15,700	5,250	265	<b>4080</b>
						20,700	31,500	10,500	400	<b>4120</b>
						28,500	47,200	15,700	530	<b>4160</b>
						32,100	55,100	18,300	660	<b>4200</b>
						39,000	70,900	23,600	800	<b>4240</b>
						45,600	86,600	28,800	930	<b>4280</b>

1N ≙ 0.102kgf



# NV TYPE

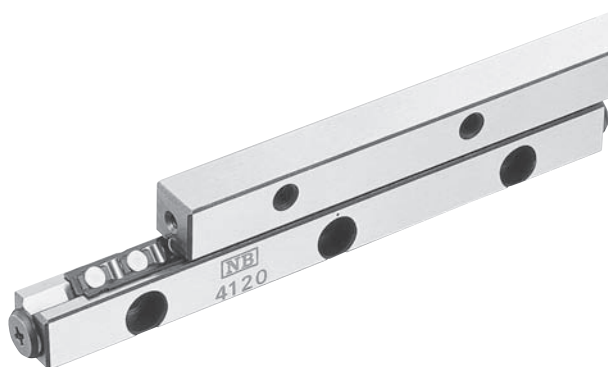
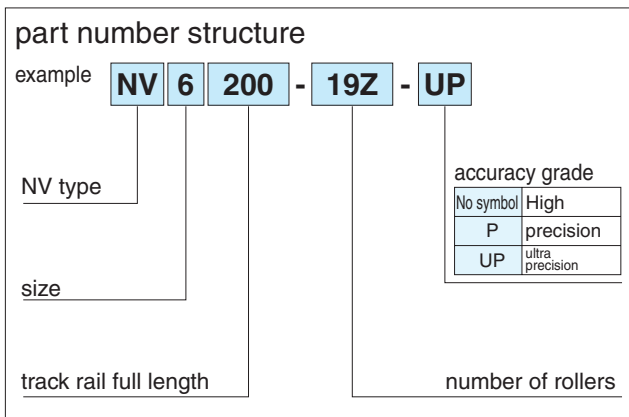

part number	stroke ST mm	roller diameter D mm	number of rollers Z	L	A	B	C	M × P	N
				mm	mm	mm	mm	mm	mm
<b>NV6100- 9Z</b>	63	6	9	100	31	15	15.15	1 × 50	25
<b>NV6150-15Z</b>	85		15	150				2 × 50	
<b>NV6200-19Z</b>	135		19	200				3 × 50	
<b>NV6250-25Z</b>	158		25	250				4 × 50	
<b>NV6300-31Z</b>	180		31	300				5 × 50	
<b>NV6350-35Z</b>	230		35	350				6 × 50	
<b>NV6400-39Z</b>	275		39	400				7 × 50	
<b>NV9200-13Z</b>	120	9	13	200	44	22	21.5	1 × 100	50
<b>NV9300-21Z</b>	170		21	300				2 × 100	
<b>NV9400-29Z</b>	220		29	400				3 × 100	
<b>NV9500-35Z</b>	300		35	500				4 × 100	
<b>NV12300-15Z</b>	180	12	15	300	58	28	28.5	2 × 100	50
<b>NV12400-21Z</b>	230		21	400				3 × 100	
<b>NV12500-27Z</b>	280		27	500				4 × 100	
<b>NV12600-31Z</b>	380		31	600				5 × 100	

The basic static load rating is the value at the center of the stroke.

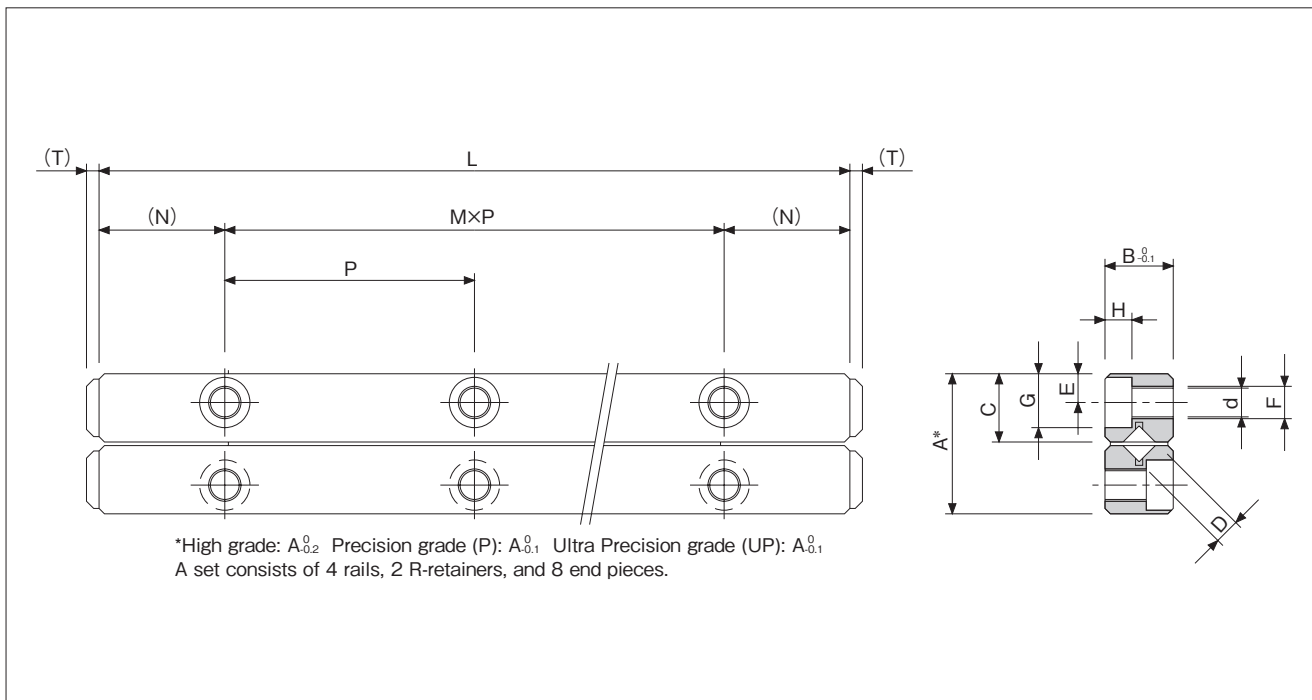

major dimensions						basic load rating		allowable load F N	mass g	size
E mm	F	d mm	G mm	H mm	T mm	dynamic C N	static Co N			
6	M6	5.2	9.5	5.2	3	29,600	37,500	12,500	650	<b>6100</b>
						50,900	75,100	25,000	970	<b>6150</b>
						60,600	93,900	31,300	1,300	<b>6200</b>
						69,800	112,000	37,500	1,620	<b>6250</b>
						87,000	150,000	50,000	1,940	<b>6300</b>
						95,000	169,000	56,000	2,360	<b>6350</b>
9	M8	6.8	10.5	6.2	4	104,000	187,000	62,000	2,780	<b>6400</b>
						96,000	128,000	42,000	2,720	<b>9200</b>
						143,000	213,000	71,000	4,080	<b>9300</b>
						186,000	298,000	99,000	5,440	<b>9400</b>
12	M10	8.5	13.5	8.2	4	226,000	384,000	128,000	6,790	<b>9500</b>
						228,000	317,000	105,000	6,770	<b>12300</b>
						271,000	396,000	132,000	9,040	<b>12400</b>
						352,000	555,000	185,000	11,300	<b>12500</b>
						391,000	635,000	211,000	13,560	<b>12600</b>

1N ≙ 0.102kgf



# NVT TYPE

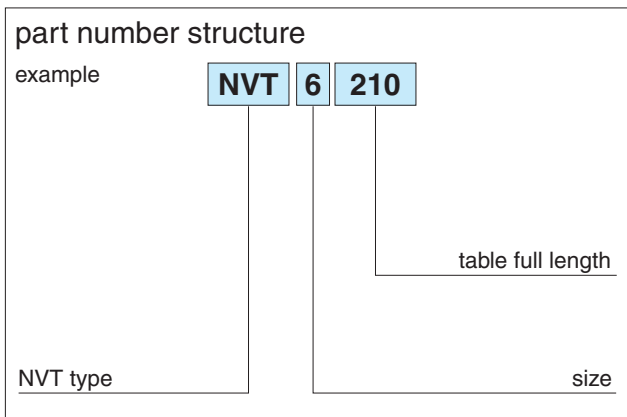
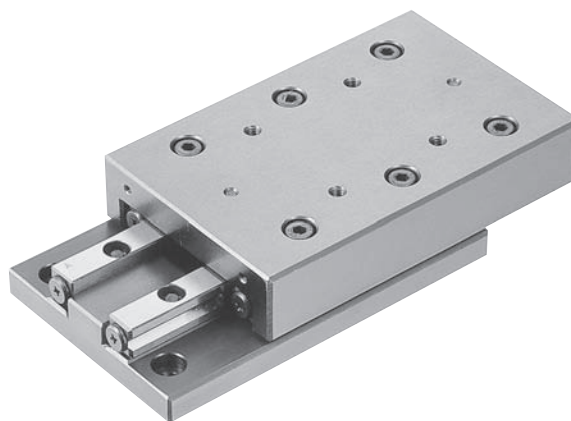

part number	stroke ST mm	dimensions				table-top mounting hole dimensions					table-end mounting hole dimensions																				
		A mm	B mm	L mm	b mm	P <sub>1</sub> mm	S <sub>1</sub>	ℓ <sub>a</sub> mm	N mm	M × P mm	h <sub>1</sub> mm	h <sub>2</sub> mm	t <sub>1</sub> mm	t <sub>2</sub> mm	S <sub>2</sub>	ℓ <sub>b</sub> mm	P <sub>2</sub> mm														
<b>NVT2035</b>	18	21 ± 0.1	40 <sup>-0.2</sup> <sub>-0.4</sub>	35	14	15	M3	6	17.5	-	16	-	3.4	-	M2	6	30														
<b>NVT2050</b>	30			50						1 × 15																					
<b>NVT2065</b>	40			65						2 × 15																					
<b>NVT2080</b>	50			80						3 × 15																					
<b>NVT2095</b>	60			95						4 × 15																					
<b>NVT2110</b>	70			110						5 × 15																					
<b>NVT2125</b>	80			125						6 × 15																					
<b>NVT2140</b>	90			140						7 × 15																					
<b>NVT2155</b>	100			155						8 × 15																					
<b>NVT2170</b>	110			170						9 × 15																					
<b>NVT2185</b>	120	185	10 × 15																												
<b>NVT3055</b>	30	28 ± 0.1	60 ± 0.1	55	18.5	25	M4	8	27.5	-	40	-	5.5	-	M3	6	40														
<b>NVT3080</b>	45			80						1 × 25																					
<b>NVT3105</b>	60			105						2 × 25																					
<b>NVT3130</b>	75			130						3 × 25																					
<b>NVT3155</b>	90			155						4 × 25																					
<b>NVT3180</b>	105			180						5 × 25																					
<b>NVT3205</b>	130			205						6 × 25																					
<b>NVT3230</b>	155			230						7 × 25																					
<b>NVT4085</b>	50			35 ± 0.1						80 ± 0.1								85	24	40	M5	10	42.5	-	55	-	6.5	-	M3	6	55
<b>NVT4125</b>	75																	125						1 × 40							
<b>NVT4165</b>	105	165	2 × 40																												
<b>NVT4205</b>	130	205	3 × 40																												
<b>NVT4245</b>	155	245	4 × 40																												
<b>NVT4285</b>	185	285	5 × 40																												

The basic static load rating is the value at the center of the stroke.

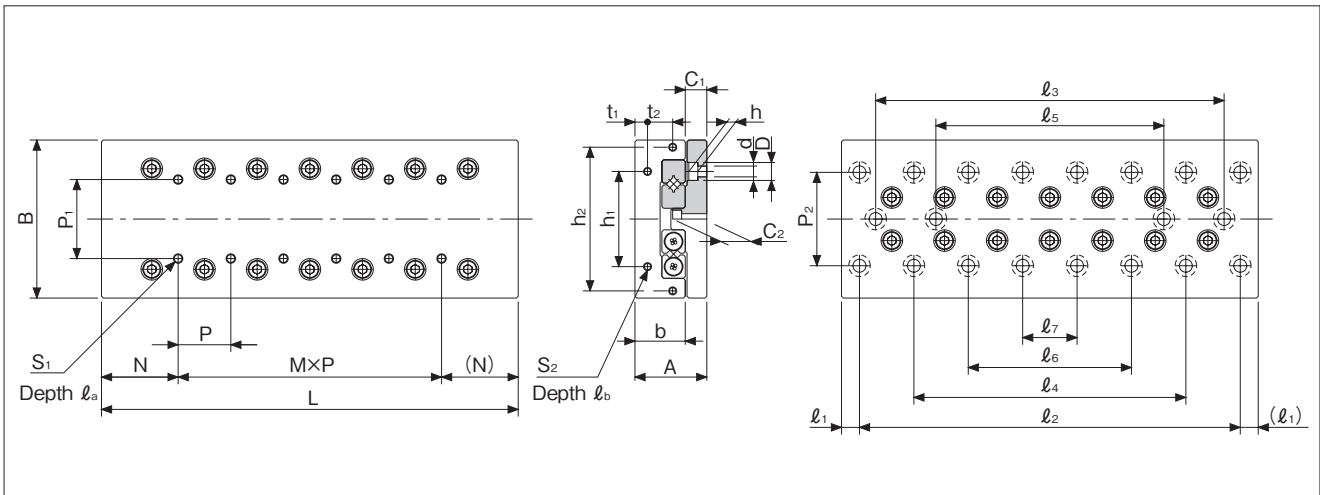

bed-surface mounting hole dimensions										motion accuracy*		basic load rating		allowable load F N	allowable static moment			mass g	size
d × D × h mm	C <sub>1</sub> mm	C <sub>2</sub> mm	l <sub>1</sub> mm	l <sub>2</sub> mm	l <sub>3</sub> mm	l <sub>4</sub> mm	l <sub>5</sub> mm	l <sub>6</sub> mm	l <sub>7</sub> mm	T μm	S μm	dynamic C N	static Co N		M <sub>p</sub> N·m	M <sub>v</sub> N·m	M <sub>R</sub> N·m		
35×65×35	6.5	10.9	5	25	—	—	—	—	—	2	4	1,360	1,520	500	10.1	8.8	13.7	200	<b>2035</b>
				40	—	—	—	—	—	2	4	2,330	3,050	1,010	19.0	18.7	21.2	287	<b>2050</b>
				55	—	—	—	—	—	2	5	3,190	4,580	1,520	36	35	35	377	<b>2065</b>
				70	—	40	—	—	—	2	5	3,990	6,110	2,030	53	53	40	455	<b>2080</b>
				85	—	55	—	—	—	2	5	4,740	7,630	2,540	80	79	53	550	<b>2095</b>
				100	—	70	—	—	—	3	6	5,460	9,160	3,050	104	106	58	640	<b>2110</b>
				115	—	85	—	—	—	3	6	6,160	10,600	3,560	130	135	63	730	<b>2125</b>
				130	—	100	—	70	—	3	6	6,830	12,200	4,070	171	176	77	810	<b>2140</b>
				145	—	115	—	85	—	3	6	7,490	13,700	4,580	217	220	91	890	<b>2155</b>
				160	—	130	—	100	—	3	7	8,130	15,200	5,090	276	289	96	980	<b>2170</b>
45×8×45	9	15	10	35	—	—	—	—	—	2	5	6,150	8,060	2,680	22.9	36	39	643	<b>3055</b>
				60	—	—	—	—	—	2	5	8,440	12,100	4,030	125	119	152	960	<b>3080</b>
				85	—	—	—	—	—	3	6	10,500	16,100	5,370	188	185	179	1,260	<b>3105</b>
				110	—	—	—	—	—	3	6	14,400	24,200	8,060	301	319	205	1,580	<b>3130</b>
				135	85	—	—	—	—	3	6	16,300	28,200	9,410	425	438	262	1,860	<b>3155</b>
				160	110	—	—	—	—	3	7	18,100	32,200	10,700	628	634	345	2,160	<b>3180</b>
				185	135	85	—	—	—	3	7	19,800	36,300	12,100	760	778	371	2,460	<b>3205</b>
				210	160	110	—	—	—	3	7	21,500	40,300	13,400	903	934	397	2,780	<b>3230</b>
5.5×10×5.4	10.5	18	10	65	—	—	—	—	—	2	5	12,100	15,700	5,250	155	146	274	1,710	<b>4085</b>
				105	—	—	—	—	—	3	6	20,700	31,500	10,500	328	356	352	2,520	<b>4125</b>
				145	—	—	—	—	—	3	7	24,700	39,300	13,100	651	657	587	3,320	<b>4165</b>
				185	105	—	—	—	—	3	7	32,100	55,100	18,300	1,060	1,090	744	4,130	<b>4205</b>
				225	145	—	—	—	—	3	7	35,600	63,000	21,000	1,570	1,580	980	4,930	<b>4245</b>
				265	185	—	—	—	—	3	7	42,400	78,700	26,200	2,090	2,170	1,050	5,730	<b>4285</b>

\* For accuracy T and S, see Page 3

1N ≅ 0.102kgf 1N·m ≅ 0.102kgf·m

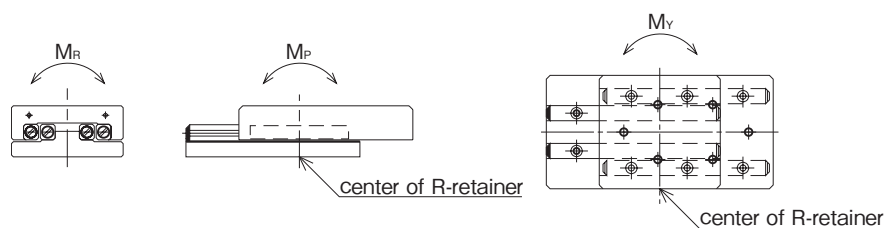



# NVT TYPE

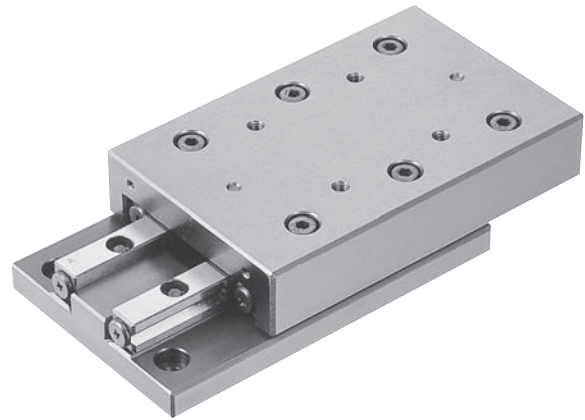
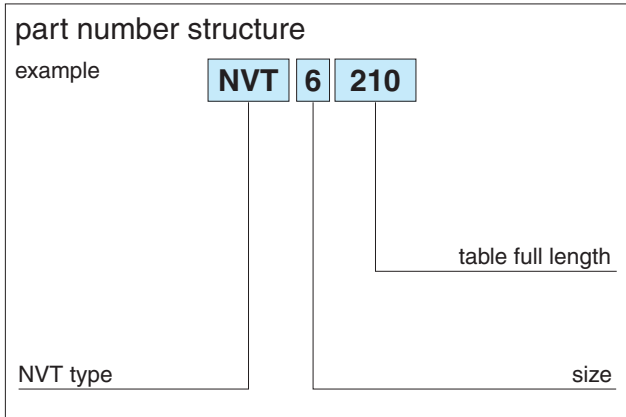

part number	stroke	dimensions				table-top mounting-hole dimensions					table-end mounting hole dimensions						
	ST mm	A mm	B mm	L mm	b mm	P <sub>1</sub> mm	S <sub>1</sub>	l <sub>a</sub> mm	N mm	M × P mm	h <sub>1</sub> mm	h <sub>2</sub> mm	t <sub>1</sub> mm	t <sub>2</sub> mm	S <sub>2</sub>		l <sub>b</sub> mm
<b>NVT6110</b>	60	45 ± 0.1	100 ± 0.1	110	31	50	M6	12	55	—	60	92	8	15	M4	8	60
<b>NVT6160</b>	95			160						1 × 50							
<b>NVT6210</b>	130			210						2 × 50							
<b>NVT6260</b>	165			260						3 × 50							
<b>NVT6310</b>	200			310						4 × 50							
<b>NVT6360</b>	235			360						5 × 50							
<b>NVT6410</b>	265			410						6 × 50							
<b>NVT9210</b>	130	60 ± 0.1	145 ± 0.1	210	43	85	M8	16	105	—	90	135	11	20	M4	8	90
<b>NVT9310</b>	180			310						1 × 100							
<b>NVT9410</b>	220			410						2 × 100							
<b>NVT9510</b>	300			510						3 × 100							

The basic static load rating is the value at the center of the stroke.

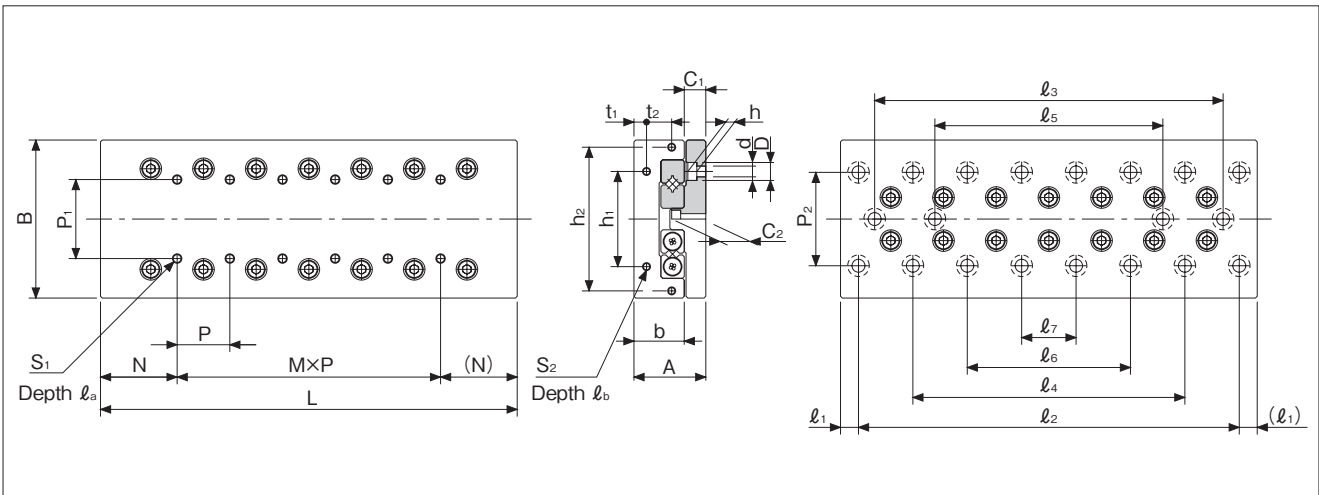

bed-surface mounting hole dimensions										motion accuracy*		basic load rating		allowable load F N	allowable static moment			mass g	size		
d × D × h mm	C <sub>1</sub> mm	C <sub>2</sub> mm	l <sub>1</sub> mm	l <sub>2</sub> mm	l <sub>3</sub> mm	l <sub>4</sub> mm	l <sub>5</sub> mm	l <sub>6</sub> mm	l <sub>7</sub> mm	T μm	S μm	dynamic C N	static Co N		M <sub>p</sub> N·m	M <sub>v</sub> N·m	M <sub>r</sub> N·m				
7×11.5×7	13	23	10	90	—	—	—	—	—	3	6	29,600	37,500	12,500	542	506	782	3,300	<b>6110</b>		
				140	—	—	—	—	—	—	3	6	40,700	56,300	18,700	947	932	1,020	4,850	<b>6160</b>	
				190	90	—	—	—	—	—	—	3	7	50,900	75,100	25,000	1,640	1,590	1,440	6,310	<b>6210</b>
				240	140	—	—	—	—	—	—	3	7	69,800	112,000	37,500	2,700	2,780	1,680	7,790	<b>6260</b>
				290	190	—	—	—	—	—	—	3	7	78,800	131,000	43,800	3,780	3,830	2,100	9,260	<b>6310</b>
				340	240	140	—	—	—	—	—	4	8	87,400	150,000	50,100	5,600	5,590	2,770	10,900	<b>6360</b>
				390	290	190	—	—	—	—	—	4	8	104,000	187,000	62,600	7,480	7,670	3,000	12,460	<b>6410</b>
9×14×9	16	29	55	100	—	—	—	—	—	3	6	96,000	128,000	42,600	1,720	2,120	2,290	12,550	<b>9210</b>		
				200	—	—	—	—	—	—	3	6	143,000	213,000	71,100	6,560	6,580	5,370	18,000	<b>9310</b>	
				300	100	—	—	—	—	—	—	3	7	186,000	298,000	99,500	12,700	12,700	7,820	24,010	<b>9410</b>
				400	200	—	—	—	—	—	—	3	7	206,000	341,000	113,000	18,700	18,700	10,200	30,100	<b>9510</b>

\* For accuracy T and S, see Page 3

1N ≅ 0.102kgf    1N·m ≅ 0.102kgf·m

