

# APPLICATION SHEET



## Conveyor

GE: **CLUTCHES**

E.A.-Nr. ohne

lfd.Nr. 19

**Type:** all complete units

**Art.-no.:** FK, FN, FND, RA

**Dimensions:** d = according to the type  
D = according to the type  
B = according to the type

**Uses as:** Indexing element  
back stop

**Branch:** Conveying systems, feed systems

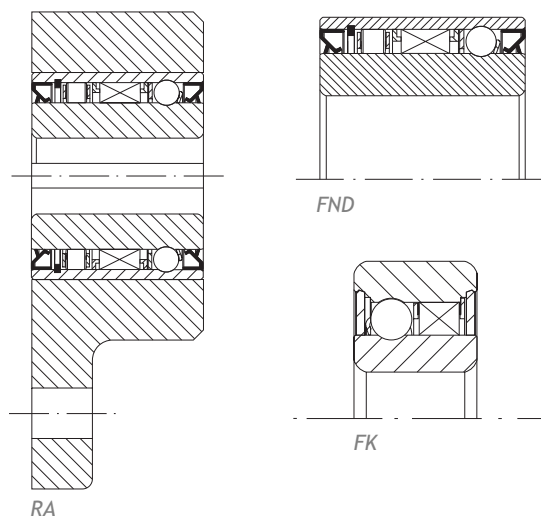

### Description:

Conveyers are common elements of internal transport systems. They are suitable for transporting huge amounts of any kind of material continuously along a fixed track. Freewheel clutches are used as backstop elements in upward and vertical conveyers to prevent any back movement in case of any problems in the driving units. Quite often certain security instructions are insisting on this kind of a security device! In horizontal conveyor system clutches are often used in the overrunning mode to allow faster movement of the material if requested and to protect the electric motor from external actuation at the same time.

### Advantages:

High torque;  
Complete units - no additional elements necessary - ease of maintenance

### Similar applications:

Chain conveyors; band conveyor, belt conveyor;  
apron conveyor; round belt conveyor; wire mesh conveyor;  
strap hindge conveyor;



[www.bergab.ru](http://www.bergab.ru)

Берг АБ [skf@bergab.ru](mailto:skf@bergab.ru) Тел.(495)-228-06-21, факс (495) 223-3071

GMN Paul Müller Industrie GmbH & Co. KG  
Äußere Bayreuther Straße 230 · D-90411 Nürnberg

Phone: +49 911-5691-417 · Fax: +49 911-5691-569  
E-Mail: [vertrieb.at@gmn.de](mailto:vertrieb.at@gmn.de)

[www.gmn.de](http://www.gmn.de)