

NSK Linear Guides

Roller Guide RA Series

A roller guide series employing advanced analysis technology offers super-high load capacity and rigidity. The RA series includes a complete lineup to handle a wide range of applications.

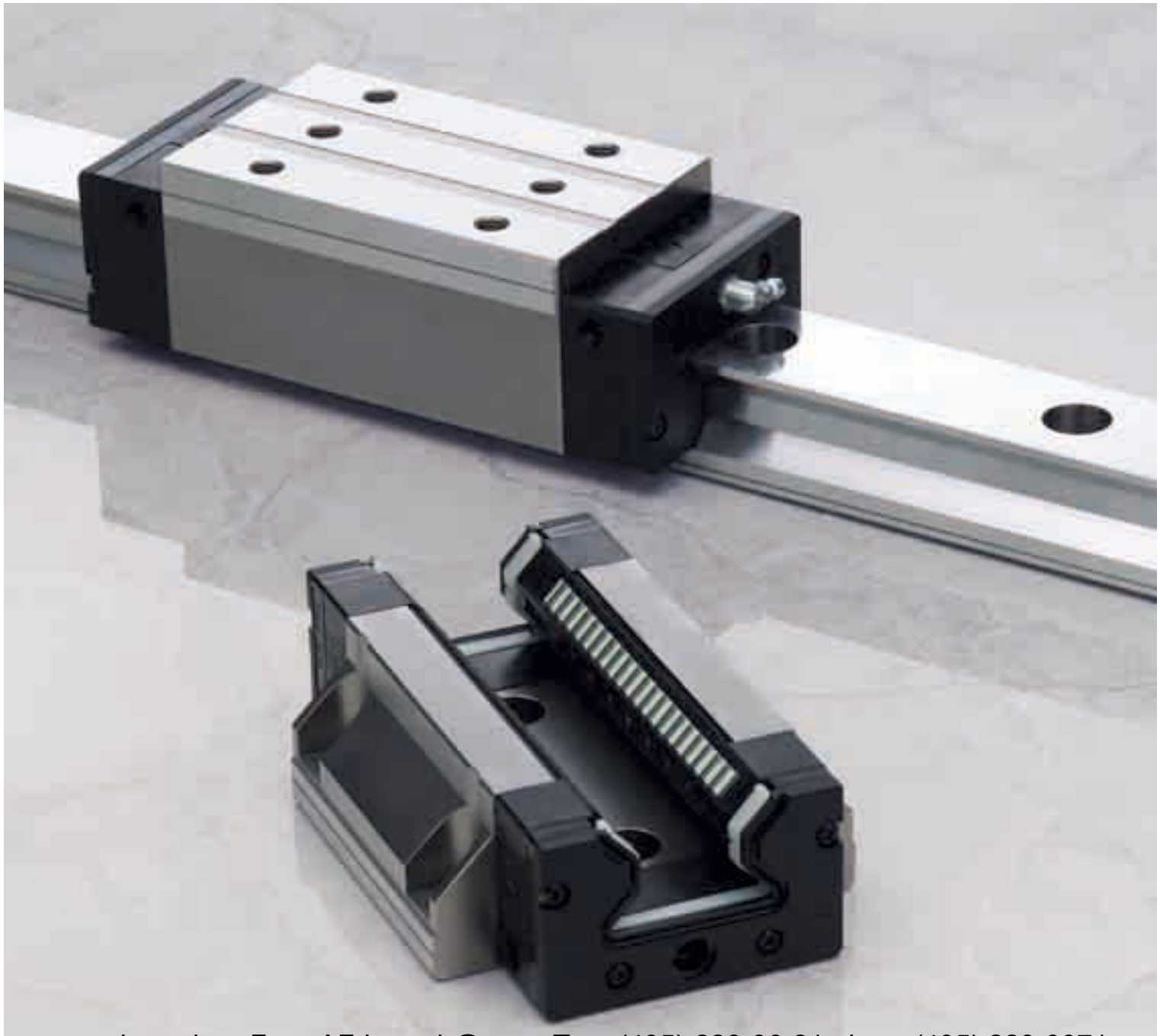

The fruits of comprehensive technology of NSK

RA series roller guides handle a diversity of applications

Roller Guide RA Series

The RA series of roller guides is the product of a combination of NSK's extensive experience in roller bearings and linear guide technologies. The result is an optimal design that takes full advantage of NSK's unique expertise to realize super-high load capacity, rigidity and motion accuracy, plus smooth motion. Capable of handling a variety of applications, the RA series supports high machine performance.

RA series features support high machine performance

Super-long Life

Super-high load capacity

NSK has realized super-high load capacity, now the highest performance in the world, and achieved unprecedented operating life.

Maintenance-free

Installing an NSK K1™ lubrication unit assures long-term, maintenance-free operation.

Highly dust-proof

The high performance seals as standard equipment completely block the entry of foreign matter and maintain primary performance over the long term.

Contribution to High-precision Manufacturing

Super-high rigidity

Super-high rigidity provides high-precision manufacturing.

Super-high motion accuracy

Coupled with NSK's unique design approach, the vibration caused by roller passage has been substantially reduced. This will greatly contribute to improve machining quality.

Smooth motion

The installation of a retaining piece achieves smooth motion, resulting in stable positioning accuracy.

Five sizes (RA15, RA20, RA25, RA30 and RA65) have been added to the RA series. NSK also introduces a low-profile size (doesn't apply to RA20 and RA65).

Used in Many Fields

Complete series

Series includes a full lineup from small to large, including low-profile sizes. You can choose the model according to the application.

Interchangeable mounting dimensions

Outside dimensions and mounting dimensions conform to standard dimensions for the market, so RA series roller guides can be used without having to alter machine design. (See page 10 for mounting surface dimensions)

Low friction

Uses rollers for rolling elements to hold down dynamic friction.

Optimal design through integration of NSK technologies

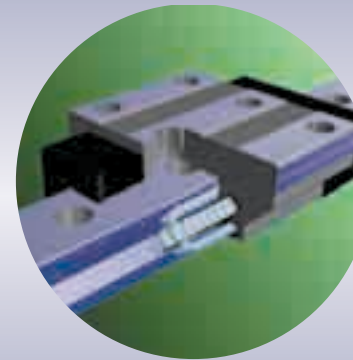

Smooth motion by use of retaining pieces

Roller Guide RA Series

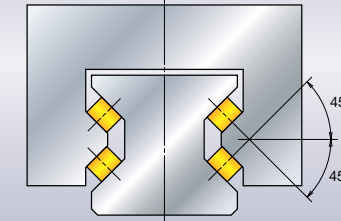

Balanced four-directional iso-load specifications



Example of roller slide deformation analysis

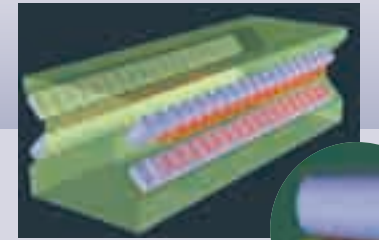

Analysis example of contact pressure distribution of rollers

NSK executed a comprehensive, detailed performance simulation of roller guides by integrating its analysis technology and the tribology technology that the company had been developing over many years. Down to the dimensions and shapes of component details, we have attained an optimal design completely.



NSK roller guide RA series exhibits the world's highest load capacity and enhance the performance of machine through a variety of features, including super-high rigidity, super-high motion accuracy, and low friction variation.

Features

Super-high load capacity

By installing rollers that are the largest possible diameter and length within the existing standard cross-section dimension in a rational layout based on analysis technology, we have realized the world's highest load capacity,* far superior to conventional roller guides. Super-long life is achieved and impact load can be sufficiently handled.

* Compared with products of the same size, as of September 1, 2003, researched by NSK.

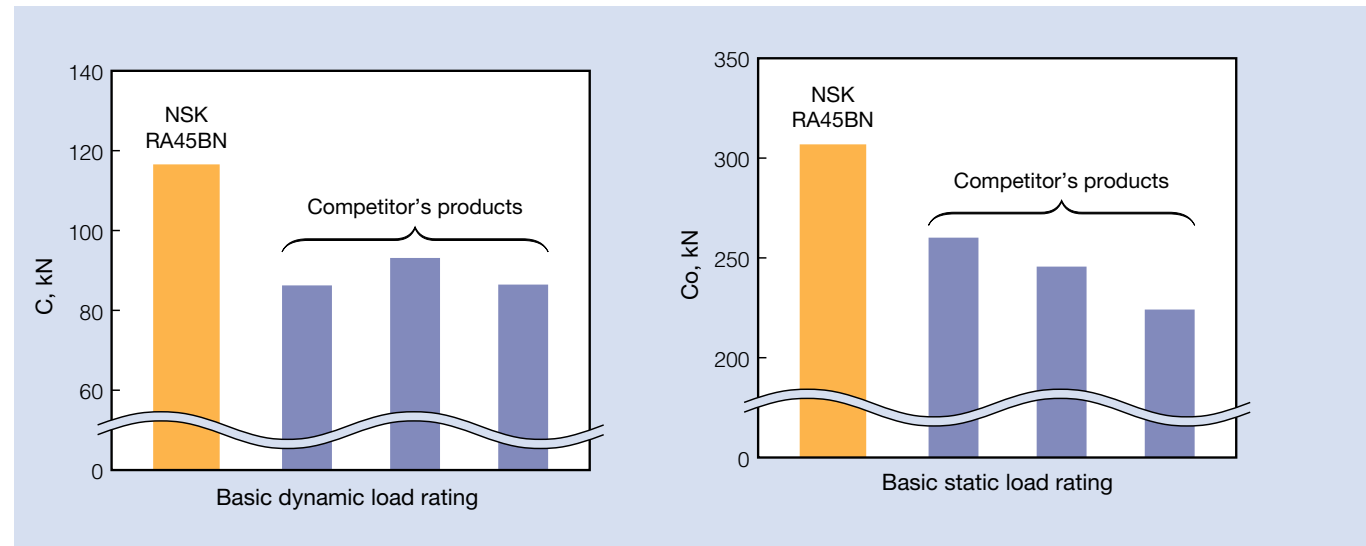

The basic load rating which is shown in the figures complies with ISO standards.

Standards for basic dynamic load rating: ISO14728-1

Standards for basic static load rating: ISO14728-2

Super-high rigidity

Using NSK's advanced analysis technology, we pursued a complete, optimal design, down to the detailed shape of roller slides and rails, thereby realizing super-high rigidity superior to that of competitor's roller guides.

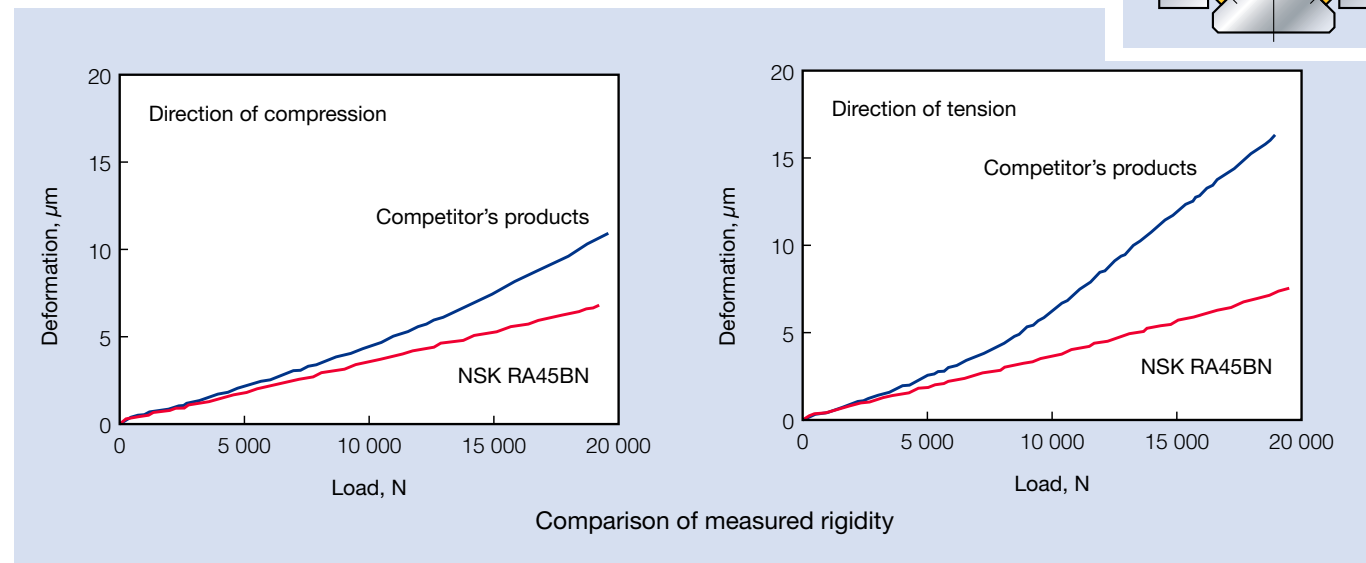
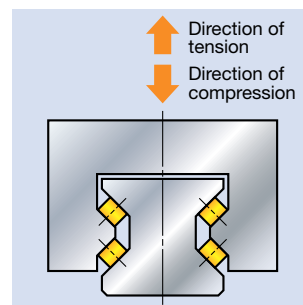

Super-high motion accuracy

NSK has developed its own unique method of simulating rolling element passage vibration and method of designing optimal roller slide specifications for damping roller passage vibration. These developments have dramatically enhanced roller slide motion accuracy for the RA series.

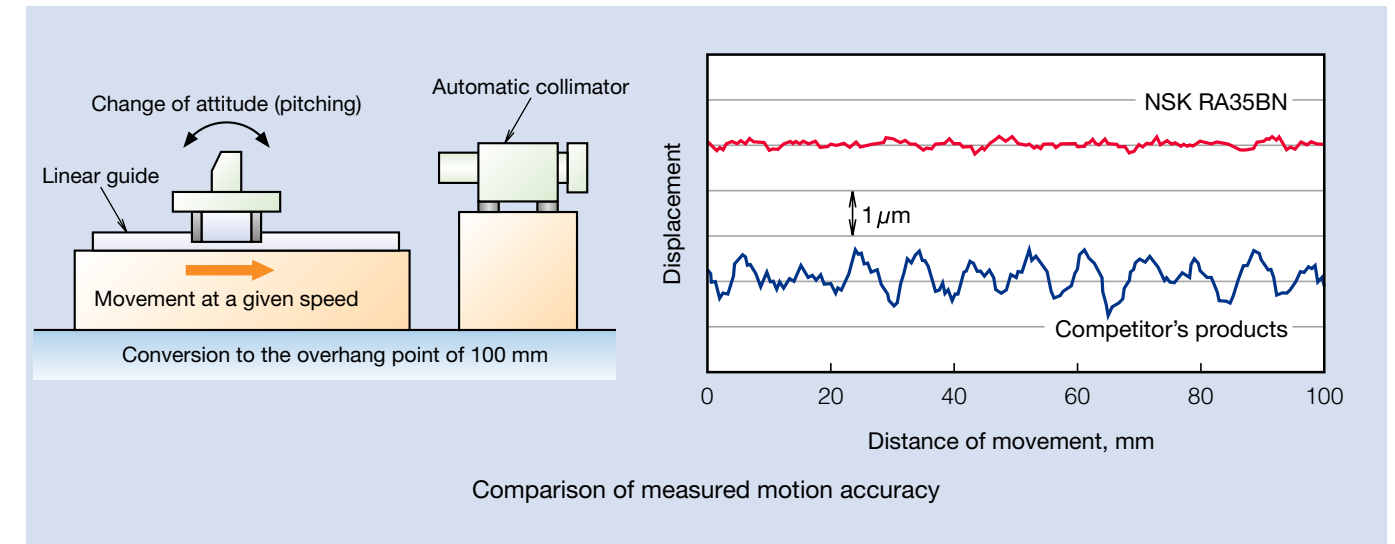

Smooth motion

Installing a retaining piece between rollers and restraining the skew peculiar to roller bearings achieve smooth motion. The reduction of friction variation provides stable tracking in the complicated trajectory control.

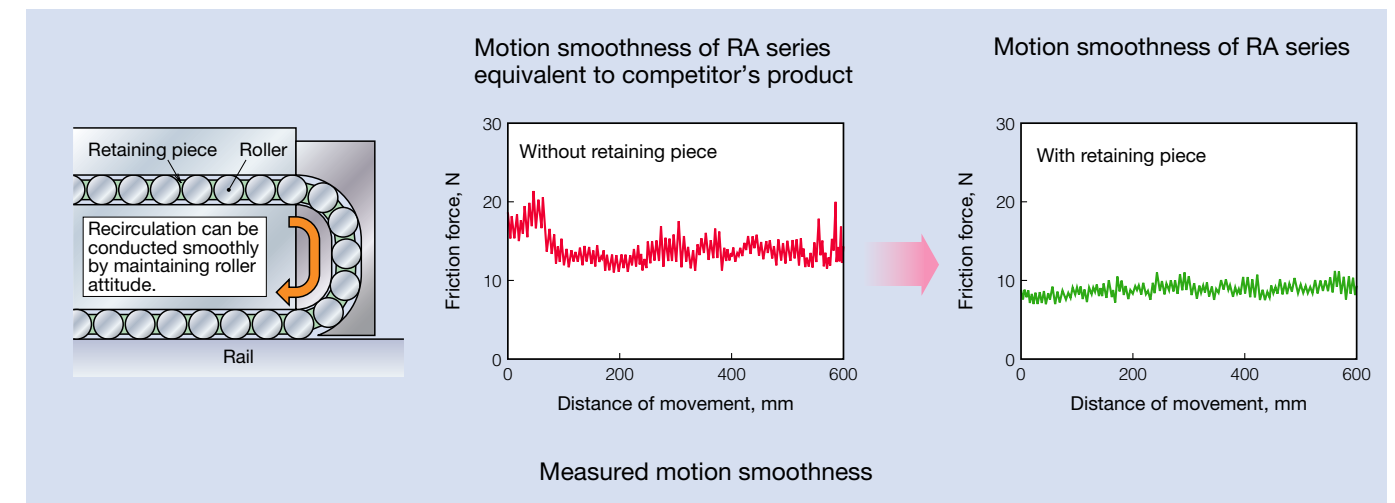

Mounting dimensions compatibility

The outer and mounting dimensions of RA series are based on market standards. RA series can be replaced without altering equipment design. (See page 10 for mounting surface dimensions)

Low friction

Using rollers for rolling elements helps minimize dynamic friction.

Measurement conditions
 • Lubrication: Oil (VG68)
 • Feeding speed: 1 m/min

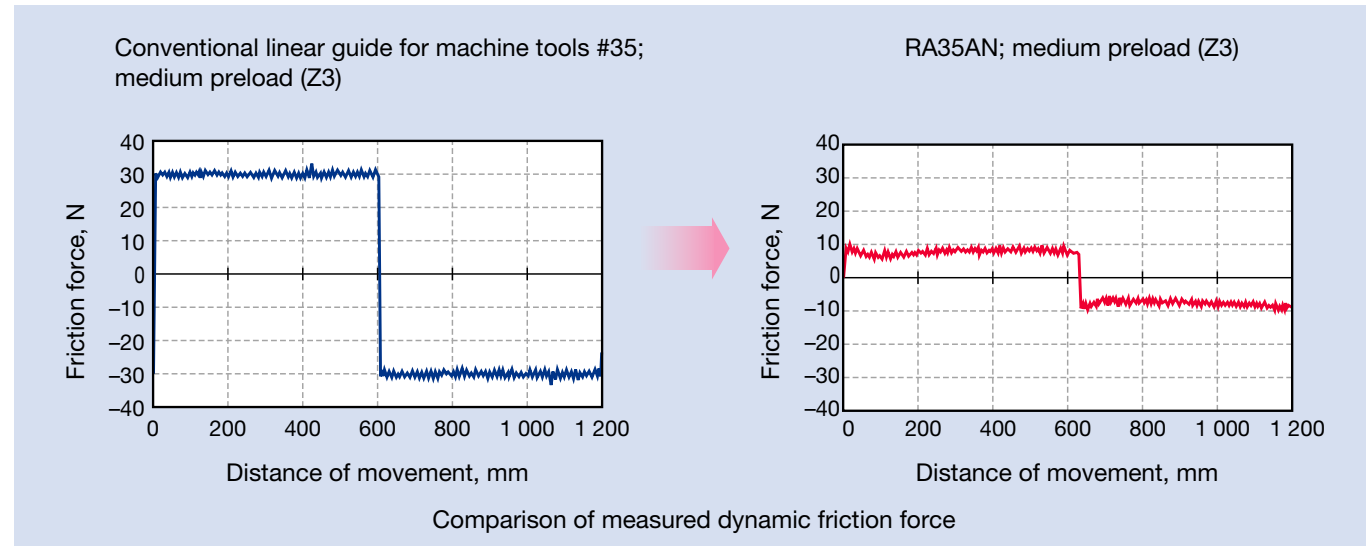

Highly dust-proof and maintenance-free operation

Roller slides include high performance seals as standard equipment. The seal completely blocks the entry of foreign matter in to the rolling surface and prevents loss of performance. In addition, rail covers are also available for severe operating conditions. (Rail covers reduce the amount of foreign matter to 1/10 that of conventional linear guide for machine tools.) The highly regarded NSK K1™ lubrication unit is also available to satisfy customer needs for long-term, maintenance-free operation.

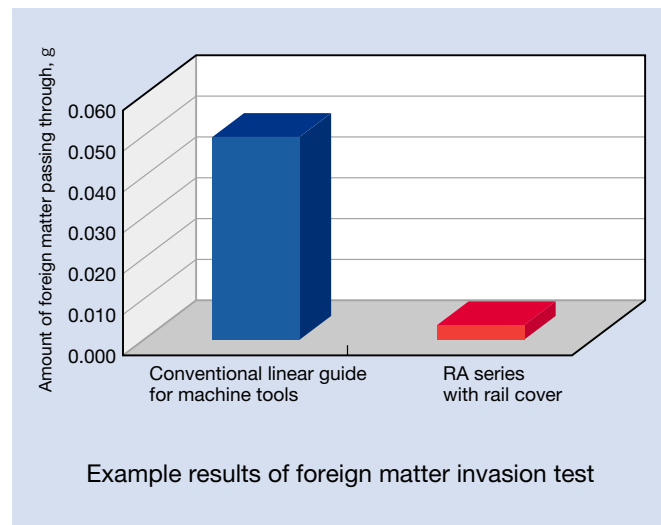

Low noise

A retaining piece is provided between rollers to prevent collision of rollers to minimize noise.

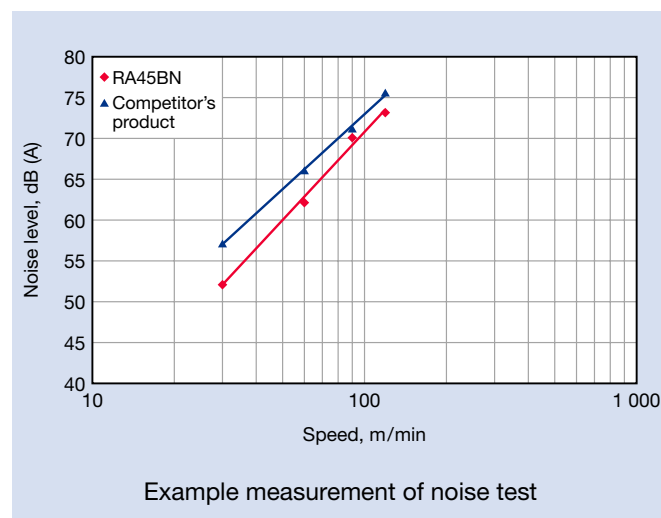

Microphone position: 500 mm above rail
 Lubrication: Oil (VG68)

Specifications

1. Roller Slide Types and Shapes

- Two types of roller slides are available in this series: one with a mounting flange and a square type with tapped holes and no flange.
- A compact, low-profile square type is now available.
- On the mounting hole of the flange type, the tapped part is used to fix the roller slide from the top surface, and the minor diameter can be used as a bolt hole from the bottom. This provides mounting from both directions, top and bottom.
- Roller slide length can be specified by standard high load type or special long, super-high load type.

Fig. 1 Square type

Roller slide shape code

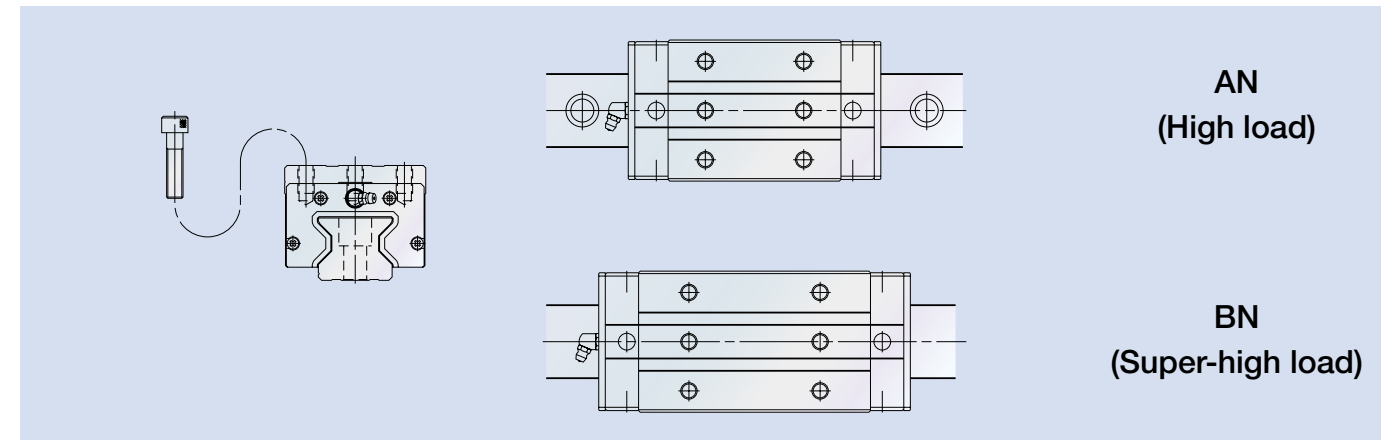

Fig. 2 Low-profile type

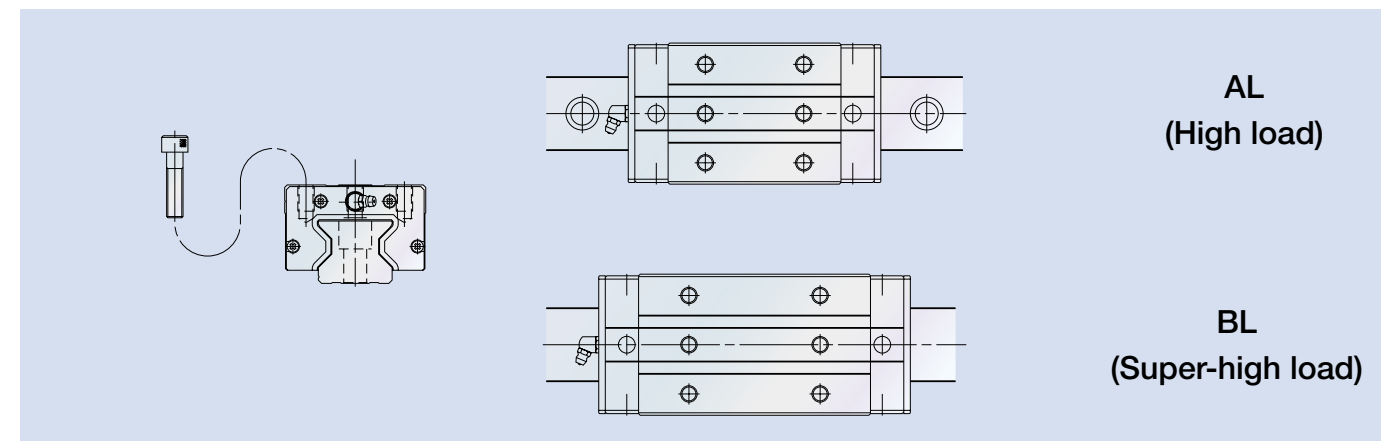
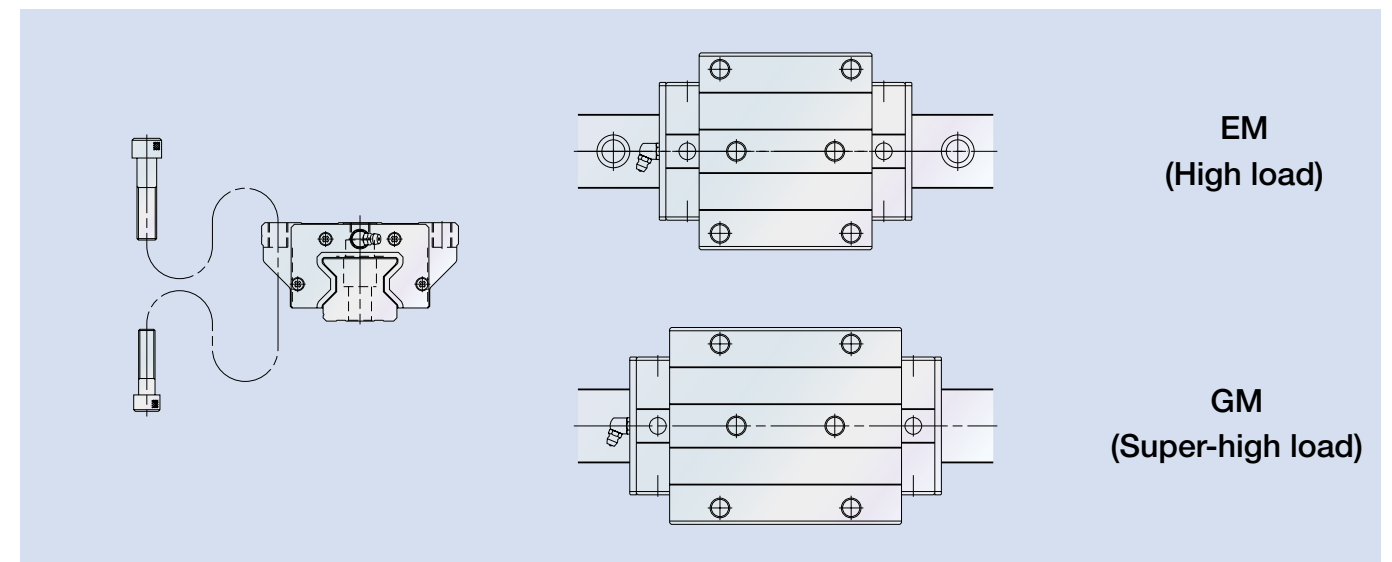

Fig. 3 Flange type



2. Accuracy

Four accuracy grades are available: ultra super precision P3, super precision P4, high precision P5, and precision P6.
*: Difference in roller slides on the reference side roller guide.

Table 1 Accuracy standards

Unit: mm

Accuracy standards	Accuracy grades			
	Ultra super precision P3	Super precision P4	High precision P5	Precision P6
Mounting height: Dimensions in mounting height H	±0.008	±0.010	±0.020	±0.040
Mounting width: Dimensions in mounting width W_2 or W_3	±0.010	±0.015	±0.025	±0.050
Variation of mounting height dimension H	0.003	0.005	0.007	0.015
Variation of mounting width dimension W_2 or W_3^*	0.003	0.007	0.010	0.020
Running parallelism of face C against face A Running parallelism of face D against face B	Refer to Table 2			

Table 2 Running parallelism

Unit: μm

Rail length (mm)	Ultra super precision P3	Super precision P4	High precision P5	Precision P6
Over - 50 or less	2	2	2	4.5
50 - 80	2	2	3	5
80 - 125	2	2	3.5	5.5
125 - 200	2	2	4	6
200 - 250	2	2.5	5	7
250 - 315	2	2.5	5	8
315 - 400	2	3	6	9
400 - 500	2	3	6	10
500 - 630	2	3.5	7	12
630 - 800	2	4	8	14
800 - 1 000	2.5	4.5	9	16
1 000 - 1 250	3	5	10	17
1 250 - 1 600	4	6	11	19
1 600 - 2 000	4.5	7	13	21
2 000 - 2 500	5	8	15	22
2 500 - 3 000	6	9.5	17	25

Fig. 4 Specifications of accuracy

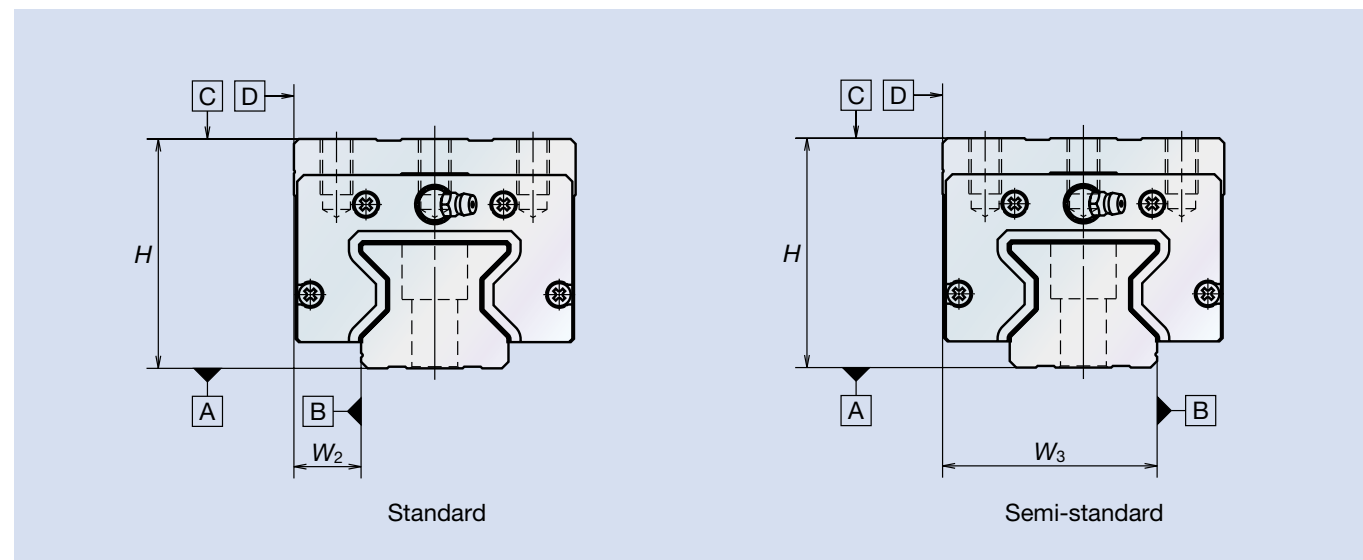

3. Preload and Rigidity

Preload is set for the RA series by slightly changing the size of the roller used. Applying preload enhances rigidity and minimizes elastic deformation.

With the characteristics of the roller guide, there is minimal variation in rigidity according to amount of preload. Because the RA series offers stable, high rigidity, only medium preload type Z3 (preload: 10% of C, where C is the basic dynamic load rating) is set. Typical measurements for preload and rigidity are as follows.

Table 3 Preload and rigidity

Model No.	Preload (N)	
	Medium preload (Z3)	
	High load capacity type AL, AN, EM	Ultra high load capacity type BL, BN, GM
RA15	1 030	1 300
RA20	1 920	2 400
RA25	2 920	3 540
RA30	3 890	4 760
RA35	5 330	6 740
RA45	9 280	11 600
RA55	12 900	16 800
RA65	21 000	28 800

Fig. 5 Direction of load

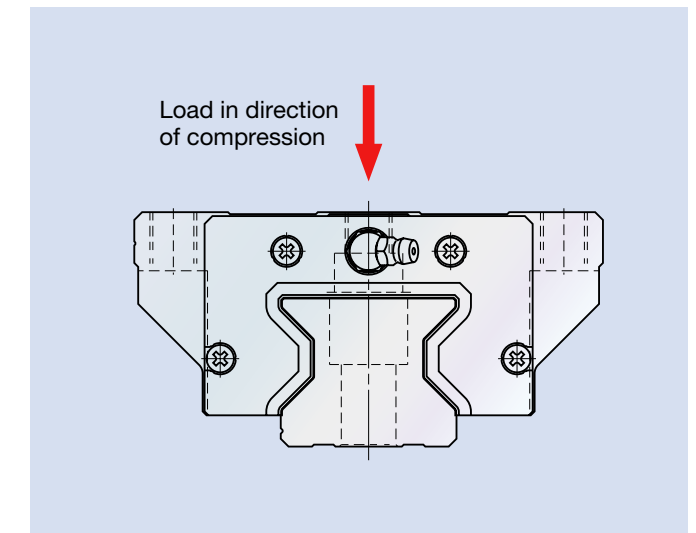
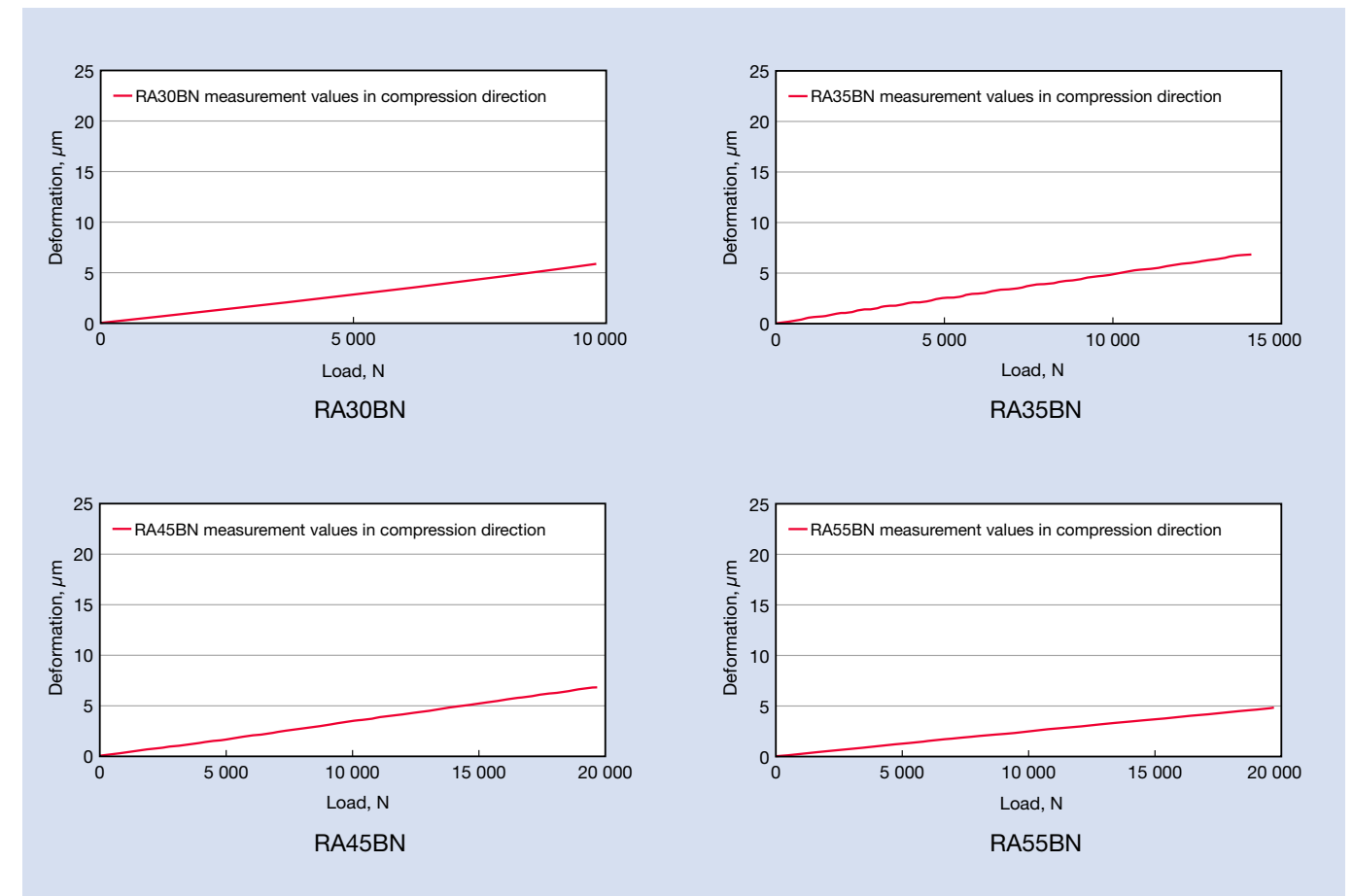

Fig. 6 Rigidity measurement data



4. Basic Load Rating and Rated Life

Basic dynamic load rating that expresses load capacity is established by ISO standards (ISO14728-1) for linear guides. With basic dynamic load rating, direction and size do not fluctuate so that rated fatigue life is 100 km. Load rating for NSK linear guides complies with ISO standards. With the RA series, dynamic load rating is the same in both the vertical and horizontal directions (4-way equal load specs.). Rated fatigue life L is calculated by the following formula when load F is applied to the roller slide in the horizontal or vertical direction only.

- This life formula is different from that for linear guides with ball rolling elements.
- f_w is load factor. Refer to the respective value from the following table 4 as a guideline according to potential vibration and the impact of the machine in which the linear guide is used, and select the load factor.

$$L = 100 \times \left(\frac{C}{f_w \cdot F} \right)^{\frac{10}{3}} \text{ (km)}$$

- When load R in the horizontal direction and load S in the vertical direction are simultaneously applied, use the following dynamic equivalent load F for the calculation:

$$F = R + 0.5S \text{ (} R \geq S \text{)}$$

$$F = S + 0.5R \text{ (} R < S \text{)}$$

5. Lubrication Specifications

With standard specifications, grease fittings are mounted on the side of the roller slide for the RA series, but can also be mounted on the side of the end cap with optional specifications. A lubrication hole can also be provided on the top of the end cap. Openings are not provided on the top or side with standard specifications in order to prevent dust. Contact NSK for more information.

Table 3 Load factor f_w

Impact and/or vibration	Load factor
No impact and vibration from the outside	1.0 – 1.5
With impact and/or vibration from the outside	1.5 – 2.0
With heavy impact and/or vibration from the outside	2.0 – 3.0

Fig. 7 Two directional load

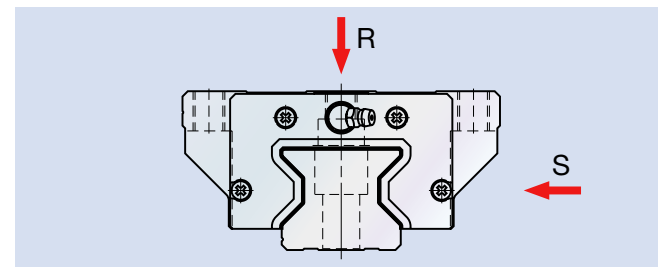

Fig. 8 Optional lubrication hole positions

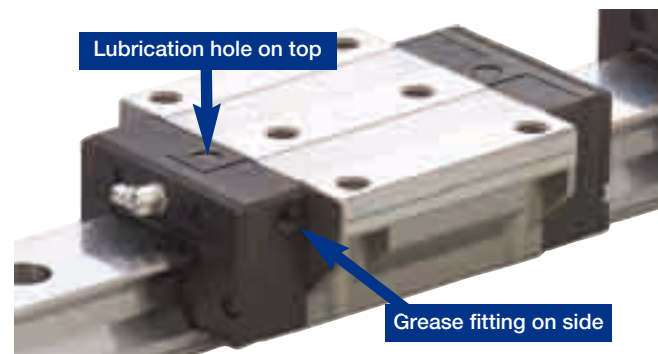
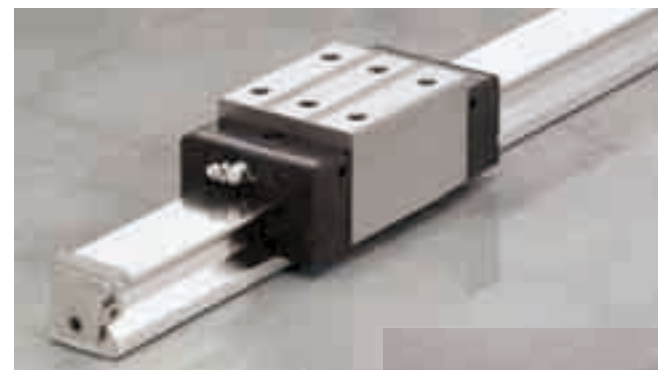

Fig. 9 Rail cover**



6. Dust-proof

RA series is equipped with side, inner* and bottom seals to prevent foreign matter from entering the inside of the roller slide. Under normal applications, the RA series can be used without modification. For severe usage conditions, optional rail covers are available. Contact NSK for information on how to mount the cover. The linear guide can also be equipped with a lubrication unit (NSK K1™) that has already proven its effectiveness with other NSK linear guides.

Table 5 Optional parts for dust-proofing

Name	Objective
NSK K1	Porous part containing oil enhances lubrication function.
Double seal	Sealing effect is enhanced by using pairs of side seals.
Protector	Removes large dust particles and protects side seals from hot and hard dust particles.
Rail cover**	Covers top of rail to prevent foreign matter from getting in the rail mounting holes.
Bolt hole cap	Prevents foreign matter such as cutting dust from collecting in the rail mounting holes.

* Inner seals for RA15 and RA20 are available as options. ** Rail cover is applicable to RA25 to 65.

7. Installation

(1) Mounting tolerance

Mounting tolerance results in harmful effects such as shortened operating life, deterioration in motion accuracy, and friction variation.

NSK particularly focuses on operating life, and sets an operating life value of more than 20 000 km calculated under the following conditions as mounting tolerance:

- The load per roller slide is 10% of basic dynamic load rating C .
- The rigidity of machine is infinite.

The tolerance in Fig. 10 is shown in the Table 6 as typical tolerance.

Fig. 10 Mounting tolerance

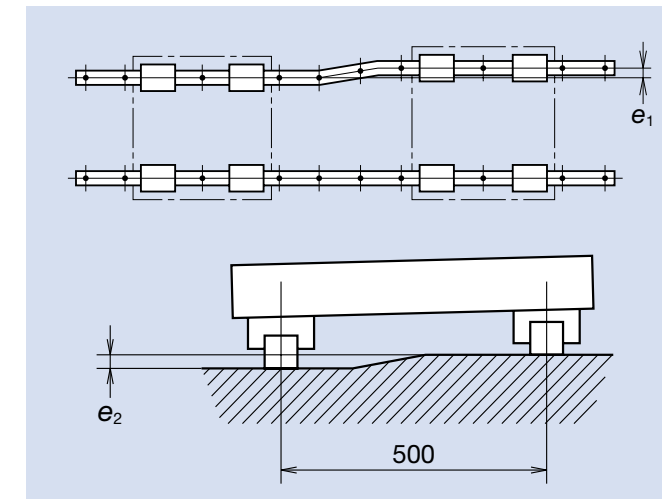

Table 6 Mounting tolerance of RA series

Model No.	Parallelism tolerance of two roller guides e_1	Height tolerance of two roller guides e_2
RA15	5	150 μm / 500 mm
RA20	7	
RA25	9	
RA30	11	
RA35	13	
RA45	17	
RA55	19	
RA65	30	

(2) Shoulder height and corner radius of mounting surface

When using the shoulders, which rise perpendicularly to the mounting surface, for accurate installation of a roller guide, refer to Fig. 11 and Table 7 for the dimensions.

Fig. 11 Datum face of roller guide and shoulder

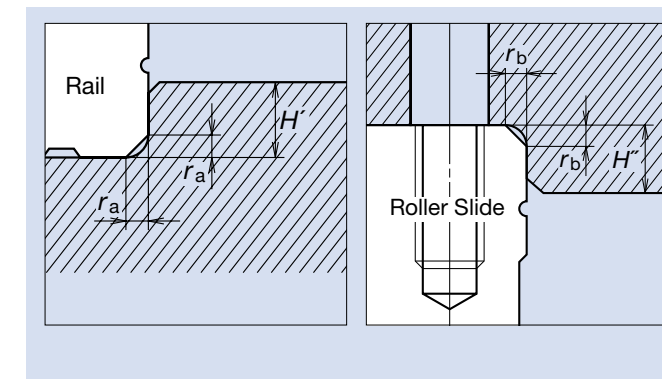

Table 7 Shoulder height and corner radius of attachment

Model No.	Shoulder Height		Chamfer (maximum)	
	H'	H''	r_a	r_b
RA15	3	4	0.5	0.5
RA20	4	5	0.5	0.5
RA25	4	5	0.5	1.0
RA30	5	6	1.0	1.0
RA35	5	6	1.0	1.0
RA45	6	8	1.5	1.0
RA55	7	10	1.5	1.5
RA65	11	11	1.5	1.5

Handling Precautions

- ① If oil lubrication is used, the oil may not pervade the rolling surface according to the roller slide mounting conditions such as upside down mounting and wall mounting. In these situations, consult with NSK.
- ② Operating temperature limits should normally be less than 80 °C.
- ③ If using NSK K1™, service temperature should not exceed 50 °C (or 80 °C instantaneously). Make sure the unit does not come in contact with organic solvents with that can be used for degreasing. Do not place the unit in a location exposed to white kerosene or rust prevention oil containing white kerosene.

Flange type (for both tapped and bolt mounting holes)

RA-EM (High load type)

RA-GM (Super-high load type)

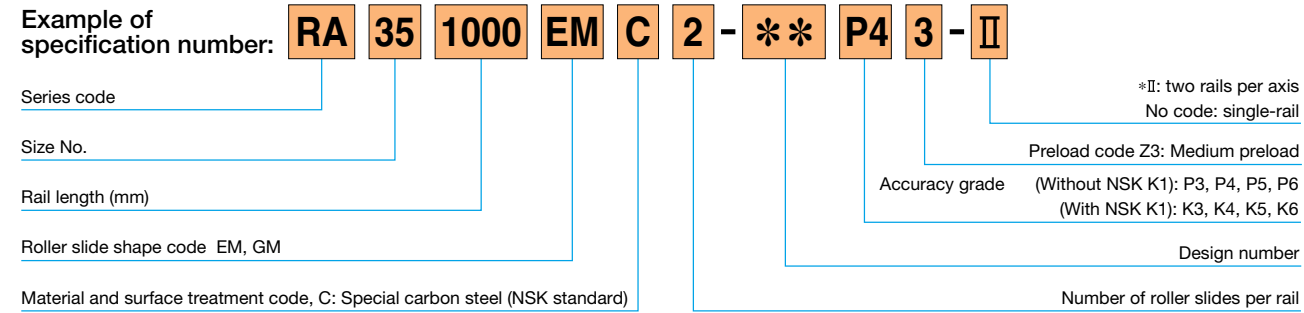

*Please note that the appropriate design number will be inserted into the reference number and the tag end code (-II) will be omitted.

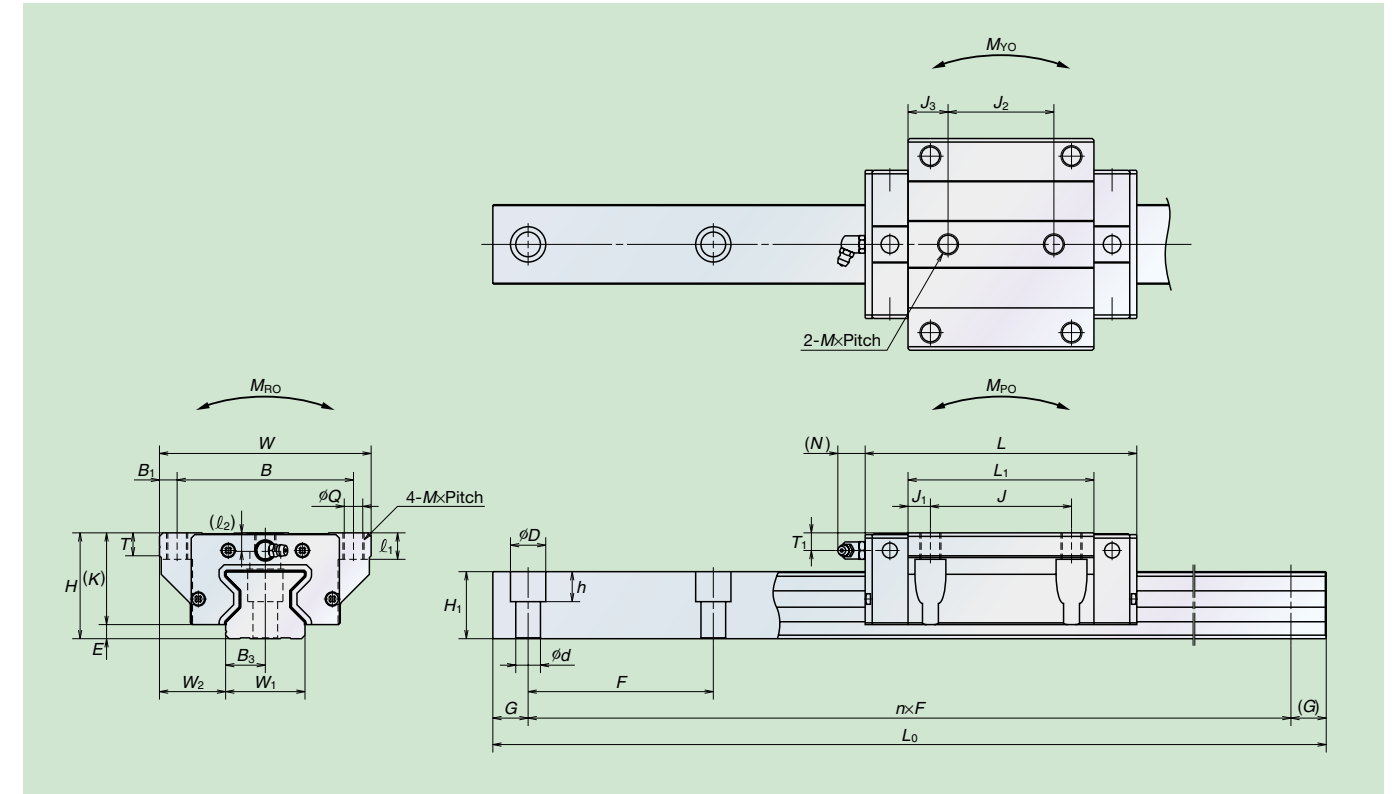

Model No.	Assembly			Roller slide													Rail							Basic load rating					Weight				
	Height H	E	W ₂	Width W	Length L	Tapped hole, Fixing bolt					B ₁	L ₁	J ₁	J ₃	K	T	Grease nipple			Rail width W ₁	Rail height H ₁	Bolt pitch F	Bolt hole d×D×h	B ₃	G (recommended)	Maximum length L _{0max}	Dynamic C (N)	Static C _G (N)	Static moment (N·m)			Bearing (kg)	Rail (kg/m)
						B	J	J ₂	M×Pitch×l ₁ (l ₂)	Q×l ₁ (l ₂)							Mounting hole	T ₁	N										M _{RO}	M _{PO}	M _{YO}		
RA15EM RA15GM	24	4	16	47	70 85.4	38	30	26	M5×0.8×8.5 (6.5)	4.4×8.5 (6.5)	4.5	44.8 60.2	7.4 15.1	9.4 17.1	20	8	∅3	4	3	15	16.3	60* (30)	4.5×7.5×5.3	7.5	20	2 000	10 300 13 000	27 500 37 000	260 350	210 375	210 375	0.21 0.28	1.6
RA20EM RA20GM	30	5	21.5	63	86.5 106.3	53	40	35	M6×1×9.5 (8)	5.3×9.5 (8)	5	57.5 77.3	8.75 18.65	11.25 21.15	25	10	∅3	4	3	20	20.8	60* (30)	6×9.5×8.5	10	20	3 000	19 200 24 000	52 500 70 000	665 890	505 900	505 900	0.45 0.65	2.6
RA25EM RA25GM	36	5	23.5	70	97.5 115.5	57	45	40	M8×1.25×10 (11)	6.8×10 (11)	6.5	65.5 83.5	10.25 19.25	12.75 21.75	31	11	M6×0.75	6	11	23	24	30	7×11×9	11.5	20	3 000	29 200 35 400	72 700 92 900	970 1 240	760 1 240	760 1 240	0.80 1.1	3.4
RA30EM RA30GM	42	6.5	31	90	110.8 135.4	72	52	44	M10×1.5×12 (12.5)	8.6×12 (12.5)	9	74 98.6	11 23.3	15 27.3	35.5	11	M6×0.75	7	11	28	28	40	9×14×12	14	20	3 000	38 900 47 600	93 500 121 000	1 670 2 170	1 140 1 950	1 140 1 950	1.3 1.7	4.9
RA35EM RA35GM	48	6.5	33	100	123.8 152	82	62	52	M10×1.5×13 (7)	8.6×13 (7)	9	83.2 111.4	10.6 24.7	15.6 29.7	41.5	12	M6×0.75	8	11	34	31	40	9×14×12	17	20	3 000	53 300 67 400	129 000 175 000	2 810 3 810	1 800 3 250	1 800 3 250	1.7 2.3	6.8
RA45EM RA45GM	60	8	37.5	120	154 190	100	80	60	M12×1.75×15 (10.5)	10.5×15 (10.5)	10	105.4 141.4	12.7 30.7	22.7 40.7	52	13	R _C 1/8	10	14	45	38	52.5	14×20×17	22.5	22.5	3 000	92 800 116 000	229 000 305 000	6 180 8 240	4 080 7 150	4 080 7 150	3.2 4.3	10.9
RA55EM RA55GM	70	9	43.5	140	184 234	116	95	70	M14×2×18 (13)	12.5×18 (13)	12	128 178	16.5 41.5	29 54	61	15	R _C 1/8	11	14	53	43.5	60	16×23×20	26.5	30	3 000	129 000 168 000	330 000 462 000	10 200 14 300	7 060 13 600	7 060 13 600	5.4 7.5	14.6
RA65EM RA65GM	90	13	53.5	170	228.4 302.5	142	110	82	M16×2×24 (18.5)	14.6×24 (18.5)	14	155.4 229.5	22.7 59.75	36.7 73.75	77	22	R _C 1/8	19	14	63	55	75	18×26×22	31.5	35	3 000	210 000 288 000	504 000 756 000	19 200 28 700	12 700 28 600	12 700 28 600	12.2 16.5	22.0

* Either 60 mm or 30 mm of bolt pitch F is applicable for RA15 and RA20. 60 mm bolt pitch will be provided if not specified.

- The basic load rating complies with ISO standards (ISO14728-1, ISO14728-2). If the above basic dynamic load rating (100 km rating) is converted into 50 km rating, use the following formula:
 $C_{50\text{ km}} = 1.23 \times C_{100\text{ km}}$
- If the rail length exceeds the above limitation, you may be able to cope with the problem by rails for butting connections. Contact NSK for more information.