

NSK Linear Guides for Contaminated Environments V1 Series

NSK's advanced, high-performance seal dramatically reduces the entry of fine contaminants to less than one-tenth of existing products and provides five-times longer service life.

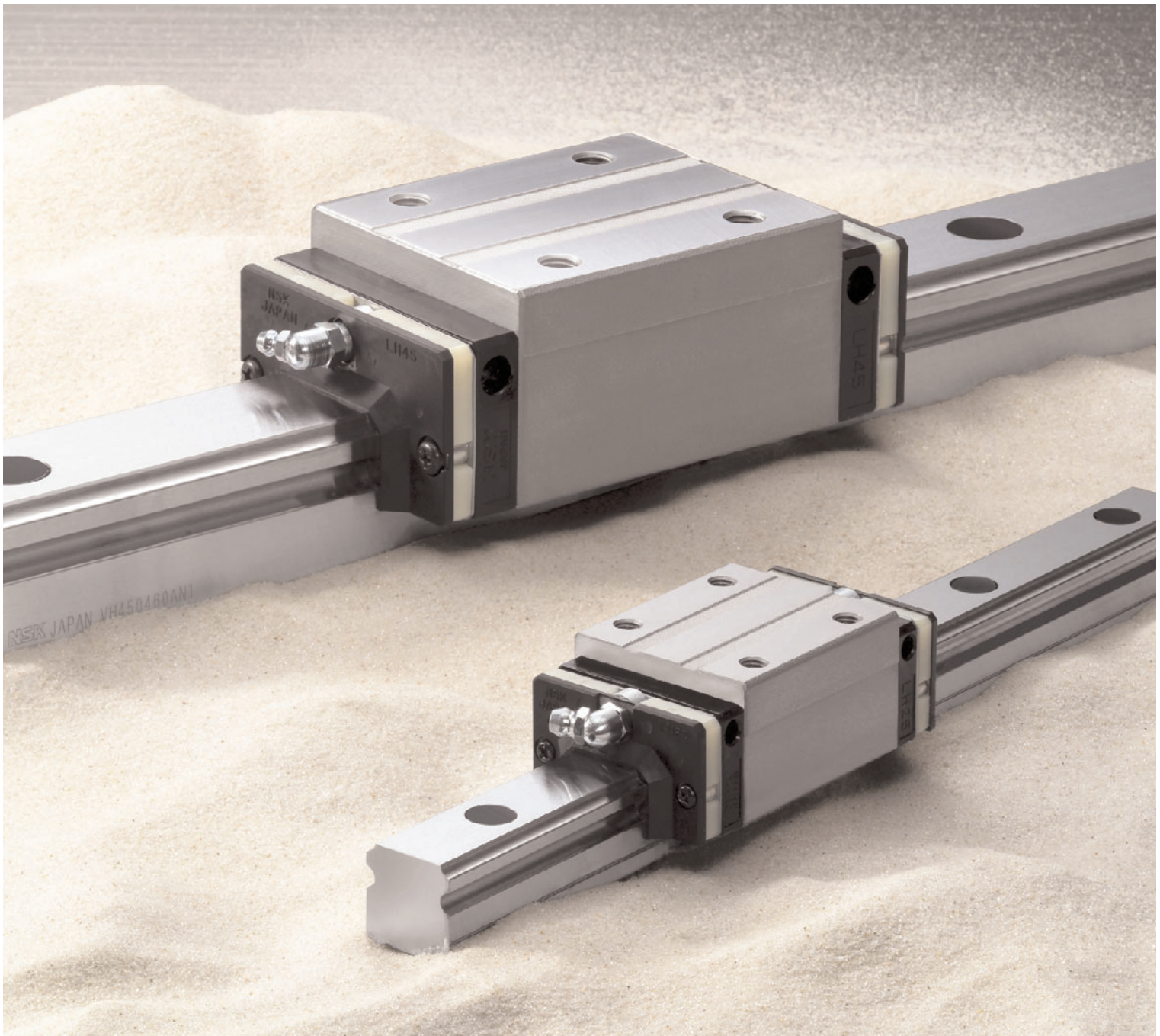

Patent Pending



With dramatically improved sealing performance, the V1 Series delivers outstanding functionality and long operating life under contaminated environments.

NSK V1 Series linear guides are designed to dramatically improve sealing capability for machinery such as equipment used for woodworking and graphite milling, which is exposed to fine particles and requires protection against the entry of fine contaminants. By adopting high-performance seals and the proven NSK K1, the V1 Series reduces the entry of fine contaminants into ball slides to less than one-tenth of existing products and realizes outstanding lubrication performance. Operating life is five times longer in dusty environments.

As a result, the V1 Series linear guides are extremely reliable and demonstrate excellent capability in contaminated environments.

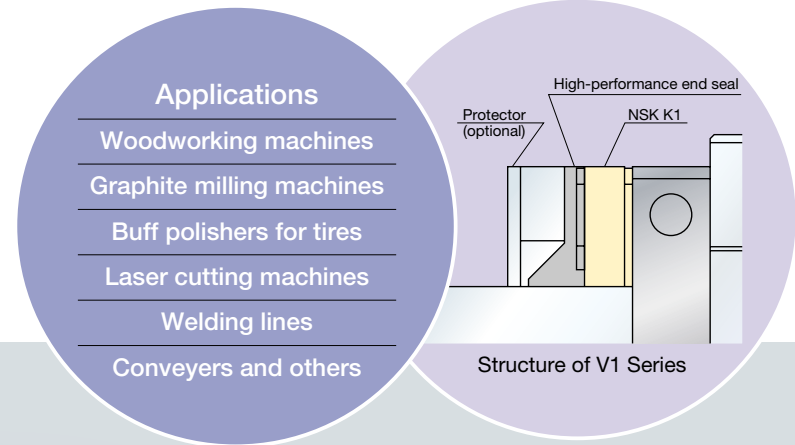

Features

Comparison with NSK standard products:

Less than **1/10** the level of fine contaminants

Results of dust-proof tests reveal that the entry of fine contaminants is reduced to less than one-tenth of existing standard series due to improvements in sealing capability.

Test conditions	
Specimen	VH30AN
Speed	16.7 mm/sec
Foreign matter	Graphite powder (average grain size: 0.037 mm) and Grease

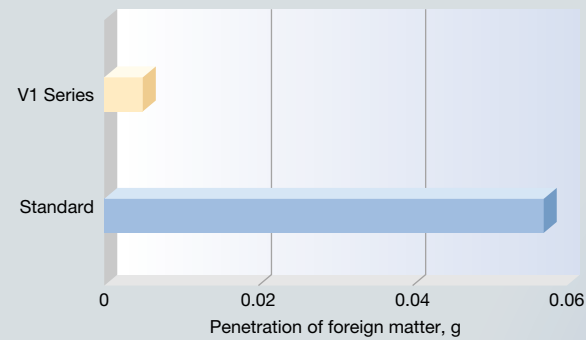

Operating life under contaminated environments is more than **5** times longer

Durability test with rubber fragments

Extreme durability tests under contaminated environments using rubber fragments show that durability of the V1 Series extended more than five times longer than the existing standard series, as shown in the graph.

Test conditions	
Specimen	VH30AN, preload with Z1 (preload of 245 N)
Rail orientation	Horizontal (wall mount)
Speed	500 mm/sec
Lubrication	Grease (charged only at the beginning)
Foreign matter	Rubber fragments

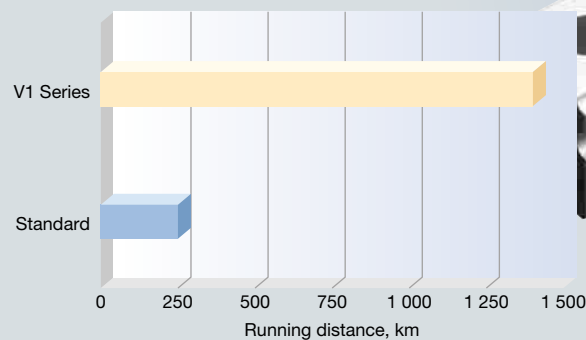

Durability test with fine wood particles

Extreme durability tests in a contaminated environment using fine wood particles show that durability of the V1 Series is more than doubled compared to the standard series, as shown in the graph.

Test conditions	
Specimen	VH30AN, preload with Z1 (preload of 3 200 N)
Rail orientation	Horizontal (wall mount)
Feed rate	400 mm/sec
Lubrication	Grease (charged only at the beginning)
Foreign matter	Fine wood particles

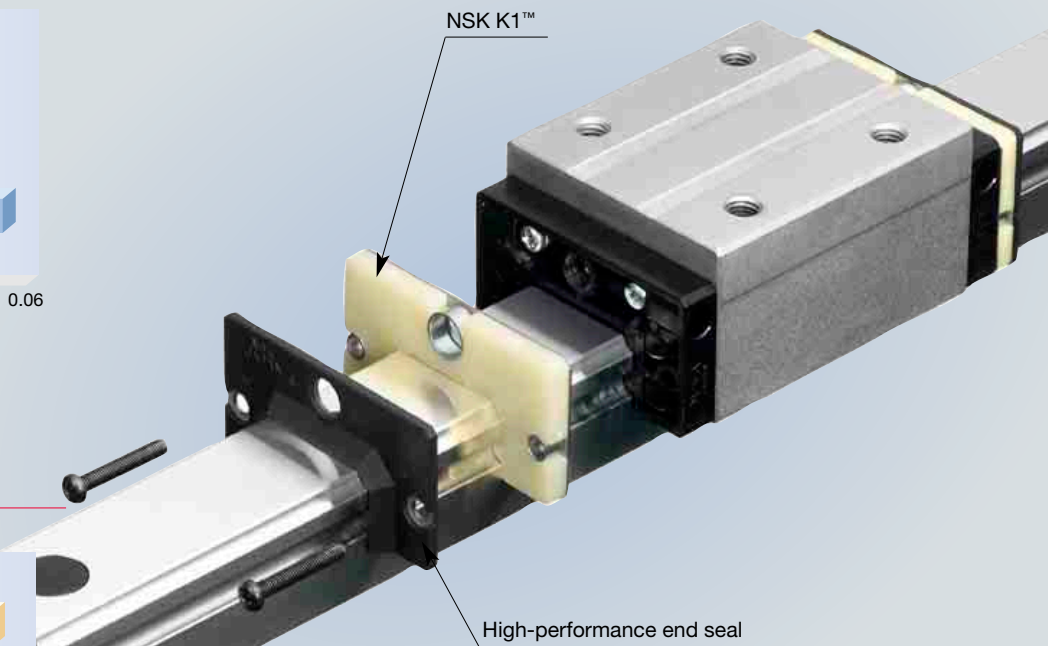
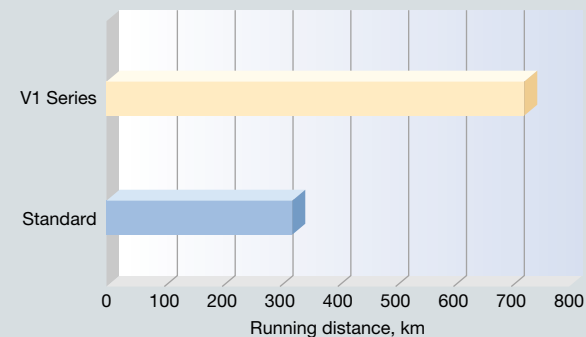

Specifications

1. High-performance end seals

High-performance side seals with a multi-lip structure prevent the entry of various foreign matters.

2. NSK K1™ lubrication unit (standard)

Outstanding lubrication support of NSK K1™ further improves sealing capability and durability. Additional NSK K1™ units can be mounted for specific usage conditions and environments.

Note: Two K1™ units, one at each end, are mounted as standard equipment on each ball slide of the V1 Series.

3. Caps for rail mounting holes enhance sealing performance

Sealing the holes for mounting bolts to eliminate the accumulation of foreign matter prevents the entry of contaminants into ball slides.

Note: Bolt hole caps are packed in linear guides prior to delivery.

4. Surface treatment

Two types of surface treatment that are optimum for linear guides are available: low-temperature chrome plating and low-temperature fluorinated chrome plating.

5. Protector (optional)

Non-contact metal protectors can be installed on the exterior of the end seal to protect the seal from heat and hard dust particles.

6. Tapped holes on a rail bottom face (optional)

In addition to standard mounting bolt holes (counterbores on a rail top face), a specification for tapped holes on a rail bottom face for enhanced sealing capability is available for the V1 Series.

Notes:

- Accuracy grade is compatible with high grade (K6) and normal grades (KN and KC)
- Minimum rail length for production is 400 mm.
- Tapping pitch is the same as the pitch for regular mounting bolt holes. Please refer to the dimensions provided in Table 10-12.
- Estimate the length of the bolt by adding 2-5 mm extra length to the effective depth of tapping.

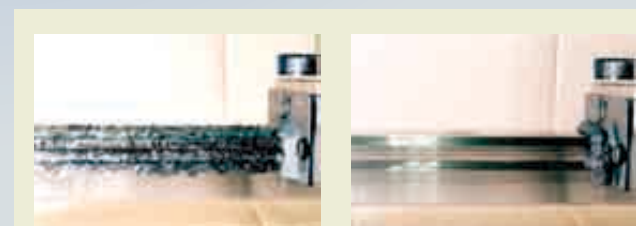

Before passage of ball slide (Significant foreign matter remains after passage of the slider)
 After passage of ball slide (All foreign matter is swept away)
 Because poor sealing capability allows foreign matter to enter the slider, foreign matter remains on the rail after the slider passes.

Reference number

The reference number may be used as a guide prior to finalizing specifications. The components of the reference number represent particular specifications; therefore when requesting estimates or inquiring about specifications, please refer to the reference number, except the design number. The reference numbers also identify single rail specifications. At least two sets of reference numbers are required for multiple rails.

Example: **VH 30 1000 AN C 2 - ** K5 1 - II**

No code: single rail
II: two rails*

Preload code: refer to Table 5

Accuracy grade code: refer to Table 4

Design serial number

Number of ball slides per rail

* Please note that the appropriate design number will be inserted into the reference number and the end code (-II) will be omitted.

Table 1 V1 Series product line

Assembly height	Length of ball slides	Ball slide shape code/mounting code			
		Square type		Flange type	
		Tapped mounting holes	Tapped mounting holes	Bolt mounting hole	For both tapped and bolt mounting holes
High type	Standard (high load)	AN	—	—	—
	Long (super high load)	BN	—	—	—
Low type	Standard (high load)	AL	EL	FL	EM
	Long (super high load)	BL	GL	HL	GM

Table 2 Ball slide mounting methods

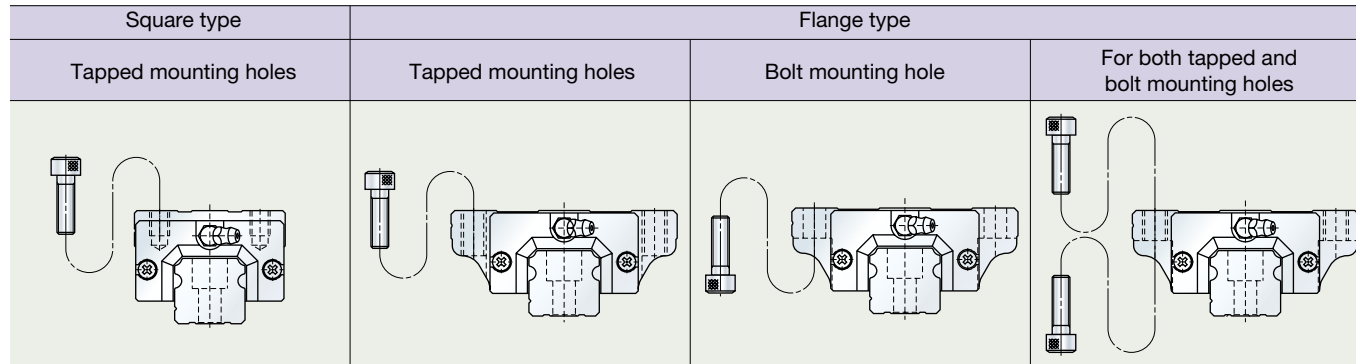

Table 3 Material and surface treatment

Code	Content	Code	Content
C	Special carbon steel (NSK standard) + counterbores on a rail top face	V	Special carbon steel (NSK standard) + tapped holes on a rail bottom face
K	Stainless steel + counterbores on a rail top face	J	Stainless steel + tapped holes on a rail bottom face
D	Special carbon steel + surface treatment + counterbores on a rail top face	W	Special carbon steel + surface treatment + tapped holes on a rail bottom face
H	Stainless steel + surface treatment + counterbores on a rail top face	S	Stainless steel + surface treatment + tapped holes on a rail bottom face
Z	Others, special	Only VH15, 20, 25 and 30 are available with stainless steel.	

Table 4 Accuracy grade

Preloaded assembly types					Interchangeable types
Ultra super precision	Super precision	High precision	Precision	Normal	Normal
K3	K4	K5	K6	KN	KC

Table 5 Preload types

Preloaded assembly types			Interchangeable type	
Medium preload	Slight preload	Fine clearance	Slight preload	Normal
Z3	Z1	Z0	ZZ	ZT

Z is omitted in the reference number.

Unit: mm

Table 6 Range of rail production

Material	Size	15	20	25	30	35	45	55
	Special carbon steel		2 000	3 960	3 960	4 000	4 000	3 990
Stainless steel		1 800	3 500	3 500	3 500	—	—	—

Rails for butting connections may be used for rail lengths that exceed the above limitation. Please consult with NSK.

Accuracy

Table 7 Accuracy standard for preloaded assembly types

Item	Accuracy Grade	Ultra super precision	Super precision	High precision	Precision	Normal
		K3	K4	K5	K6	KN
Mounting height H		± 10	± 10	± 20	± 40	± 80
Variations of mounting height H (All ball slides on a pair of rails)		3	5	7	15	25
Mounting width dimensions W_2 or W_3		± 15	± 15	± 25	± 50	± 100
Variation of mounting width dimensions W_2 or W_3 (All ball slides on datum rails)		3	7	10	20	30
Running parallelism of face C against face A Running parallelism of face D against face B		Refer to Table 9, Fig. 1 and Fig. 2				

Unit: μm

Table 8 Accuracy standard for interchangeable type

Item	Accuracy grade	Normal KC	
	Types	VH15, 20, 25, 30, 35	VH45, 55
Mounting H		± 20	± 30
Variation of mounting height H (one rail)		15	20
Variation of mounting height H (multiple rails)		30	35
Mounting width dimension W_2 or W_3		± 30	± 35
Variation of mounting width dimension W_2 or W_3		25	30
Running parallelism of face C against face A Running parallelism of face D against face B		Refer to Table 9, Fig. 1 and Fig. 2	

Unit: μm

Fig. 1 Drawing for accuracy standard (mounting with W_2)

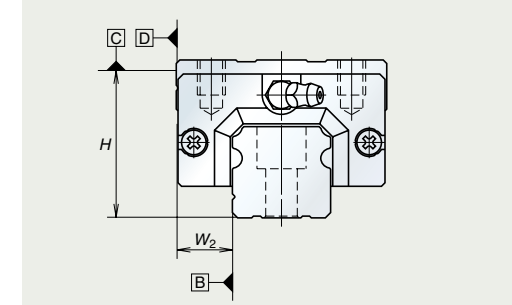

Fig. 2 Drawing for accuracy standard (mounting with W_3)

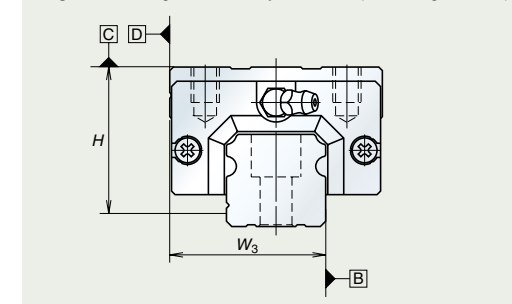

Table 9 Running parallelism tolerance

Rail length (mm)	Accuracy grade		Preloaded assembly types					Interchangeable type
	over	or less	K3	K4	K5	K6	KN	KC
50			2	2	2	4.5	6	6
50— 80			2	2	3	5	6	6
80— 125			2	2	3.5	5.5	6.5	6.5
125— 200			2	2	4	6	7	7
200— 250			2	2.5	5	7	8	8
250— 315			2	2.5	5	8	9	9
315— 400			2	3	6	9	11	11
400— 500			2	3	6	10	12	12
500— 630			2	3.5	7	12	14	14
630— 800			2	4.5	8	14	16	16
800— 1 000			2.5	5	9	16	18	18
1 000— 1 250			3	6	10	17	20	20
1 250— 1 600			4	7	11	19	23	23
1 600— 2 000			4.5	8	13	21	26	26
2 000— 2 500			5	10	15	22	29	29
2 500— 3 150			6	11	17	25	32	32
3 150— 4 000			9	16	23	30	34	34

Unit: μm

Handling Precautions

- Observe the following precautions to maintain the long-term efficiency of the high performance seals:
 1. Permissible temperature range Maximum operating temperature: 50°C
Maximum instantaneous peak temperature: 80°C
 2. Chemical precautions Never leave the linear guide near grease-removing organic solvents such as hexane or thinner. Never immerse the the linear guide in kerosene or rust preventive oils which contain kerosene.
- Carefully remove ball slides from the rails, as the balls can fall out. When the rails are tilted without the stopper, the ball slides may move along the rail and fall out.
- When ball slides are used upside down (for example, when the rails are attached to the ceiling with the ball slides down), take special precautions such as installing a safety device to prevent the ball slides from falling.

V1 Series Dimensions

- VH-AL (high load/low type)
- VH-AN (high load/high type)
- VH-BL (super high load/low type)
- VH-BN (super high load/high type)

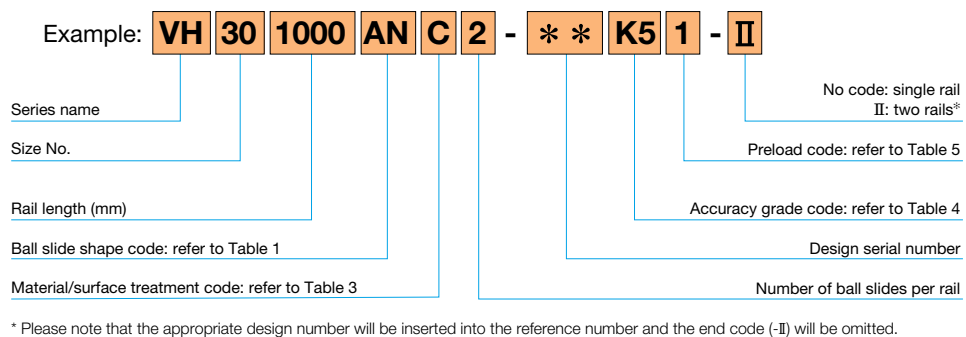

Without protector

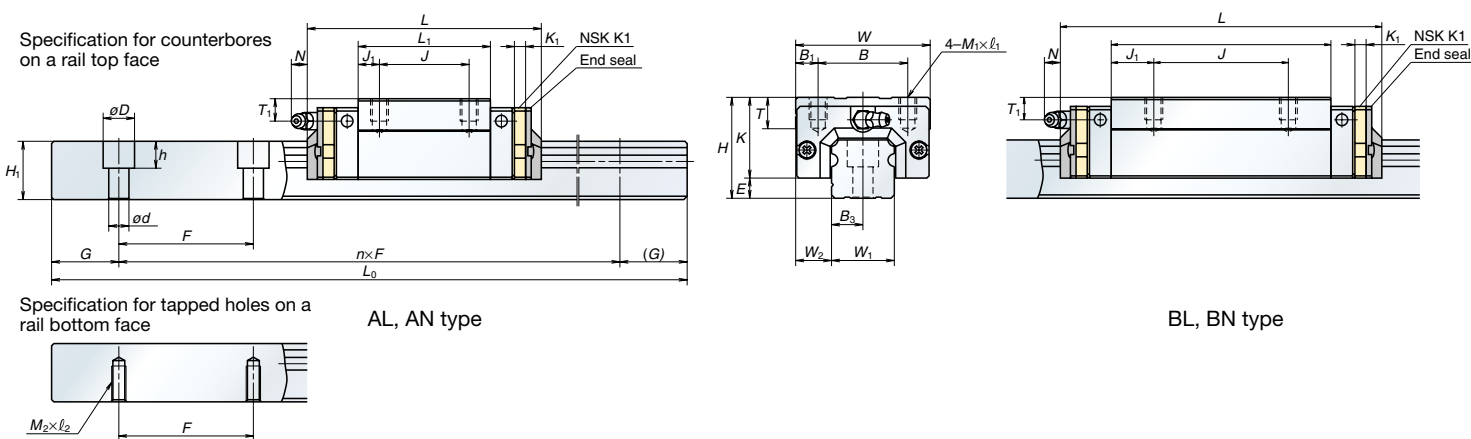

With protector

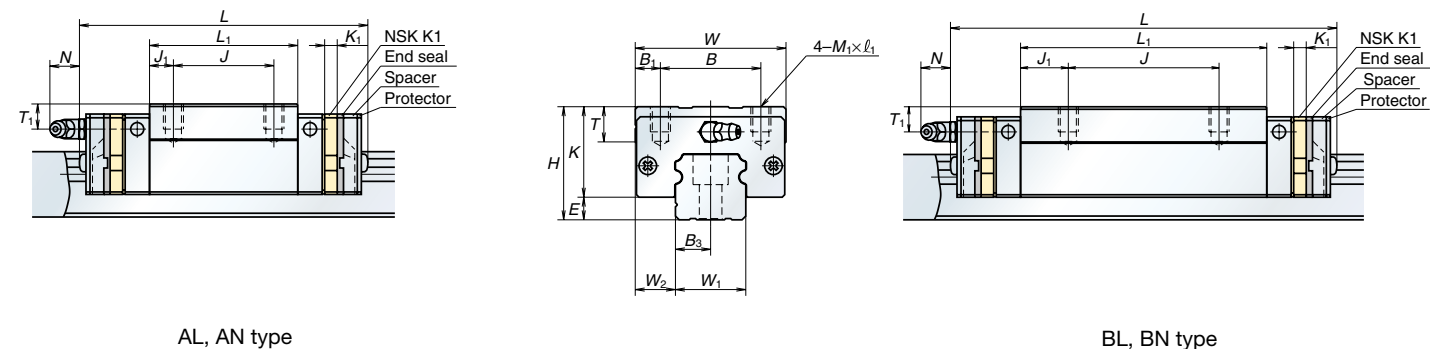

Table 10 Dimensions

Unit: mm

Model No.	Assembly			Roller slide											Rail					Basic load rating					Ball diameter		Weight						
	Height H	E	W ₂	Width W	Length L	Tapped mounting hole			B ₁	L ₁	J ₁	K	T	K ₁	Grease nipple			Rail width W ₁	Rail height H ₁	Pitch F	Counterbore d×D×h	Tapped hole M ₂ ×Pitch×ℓ ₂	B ₃	G (recommended)	Maximum length L _{max}	Dynamic C(N)	Static C ₀ (N)	Static moment (N·m)			Ball diameter D _w	Ball slide (kg)	Rail (kg/m)
						B	J	M ₁ ×Pitch×ℓ ₁							Mounting hole	T ₁	N											M _{F0}	M _{P0}	M _{V0}			
VH15AN	28	4.6	9.5	34	70.6 (77)	26	26	M4×0.7×6	4	39	6.5	23.4	8	4.5	φ3	8.5	1 (8.2)	15	15	60	4.5×7.5×5.3	M5×0.8×8	7.5	20	2 000	10 800	20 700	108	95	80	3.175	0.18	1.6
VH15BN					89.6 (96)					58	16													[1 800]	14 600	32 000	166	216	181		0.26		
VH20AN	30	5	12	44	87.4 (94.2)	32	36	M5×0.8×6	6	50	7	25	12	4.5	M6×0.75	5	11.1 (12.3)	20	18	60	6×9.5×8.5	M6×1×10	10	20	3 960	17 400	32 500	219	185	155	3.968	0.33	2.6
VH20BN					109.4 (116.2)		50			72	11													[3 500]	23 500	50 500	340	420	355		0.48		
VH25AL	36				97 (104.4)		35	M6×1×6		58	11.5	29				6									25 600	46 000	360	320	267		0.46		
VH25AN	40	7	12.5	48				M6×1×9	6.5			33	12	5	M6×0.75	10	9.6 (12.9)	23	22	60	7×11×9	M6×1×12	11.5	20	3 960	25 600	46 000	360	320	267	4.762	0.55	3.6
VH25BL	36				125 (132.4)		50	M6×1×6		86	18	29				6									34 500	71 000	555	725	610		0.69		
VH25BN	40							M6×1×9				33				10														0.82			
VH30AL	42				104.4 (114.8)		46	M8×1.25×8		59	9.5	36				7									31 000	51 500	490	350	292		0.69		
VH30AN	45	9	16	60				M8×1.25×10	10			36	14	5	M6×0.75	10	11.4 (14.2)	28	26	80	9×14×12	M8×1.25×15	14	20	4 000	31 000	51 500	490	350	292	5.556	0.77	5.2
VH30BL	42				143.4 (153.8)		60	M8×1.25×8		98	19	33				7									46 000	91 500	870	1 030	865		1.16		
VH30BN	40							M8×1.25×10				36				10														1.3			
VH35AL	48				128.8 (139.2)		50	M8×1.25×8		80	15	38.5				8									47 500	80 500	950	755	630		1.2		
VH35AN	55	9.5	18	70				M8×1.25×12	10			45.5	15	5.5	M6×0.75	15	10.9 (13.7)	34	29	80	9×14×12	M8×1.25×17	17	20	4 000	47 500	80 500	950	755	630	6.350	1.5	7.2
VH35BL	48				162.8 (173.2)		72	M8×1.25×8		114	21	38.5				8									61 500	117 000	1 380	1 530	1 280		1.7		
VH35BN	55							M8×1.25×12				45.5				15														2.1			
VH45AL	60				161.4 (174.2)		60	M10×1.5×13		105	22.5	46				10									81 000	140 000	2 140	1 740	1 460		2.2		
VH45AN	70	14	20.5	86				M10×1.5×17	13			56	17	6.5	Rc1/8	20	12.5 (14.1)	45	38	105	14×20×17	M12×1.75×24	22.5	22.5	3 990	81 000	140 000	2 140	1 740	1 460	7.937	3.0	12.3
VH45BL	60				193.4 (206.2)		80	M10×1.5×13		137	28.5	46				10									99 000	187 000	2 860	3 000	2 520		2.9		
VH45BN	70							M10×1.5×17				56				20														3.9			
VH55AL	70				185.4 (198.2)		75	M12×1.75×12		126	25.5	55				11									119 000	198 000	3 600	3 000	2 510		3.7		
VH55AN	80	15	23.5	100				M12×1.75×18	12.5			65	18	6.5	Rc1/8	21	12.5 (14.1)	53	44	120	16×23×20	M14×2×24	26.5	30	3 960	119 000	198 000	3 600	3 000	2 510	9.525	4.7	16.9
VH55BL	70				223.4 (236.2)		95	M12×1.75×12		164	34.5	55				11									146 000	264 000	4 850	51 500	4 350		4.7		
VH55BN	80							M12×1.75×18				65				21														6.1			

Figure inside < > is the dimension when equipped with the protector.

Figure inside [] is applied to stainless products.

V1 Series Dimensions

VH-EL (high load/low type)
 VH-GL (super high load/low type)

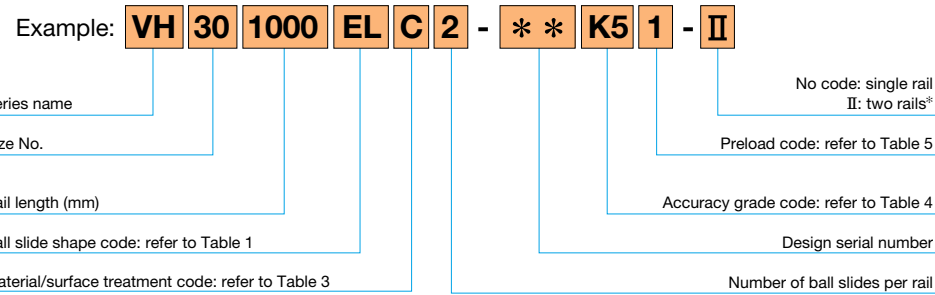

* Please note that the appropriate design number will be inserted into the reference number and the end code (-II) will be omitted.

● Without protector

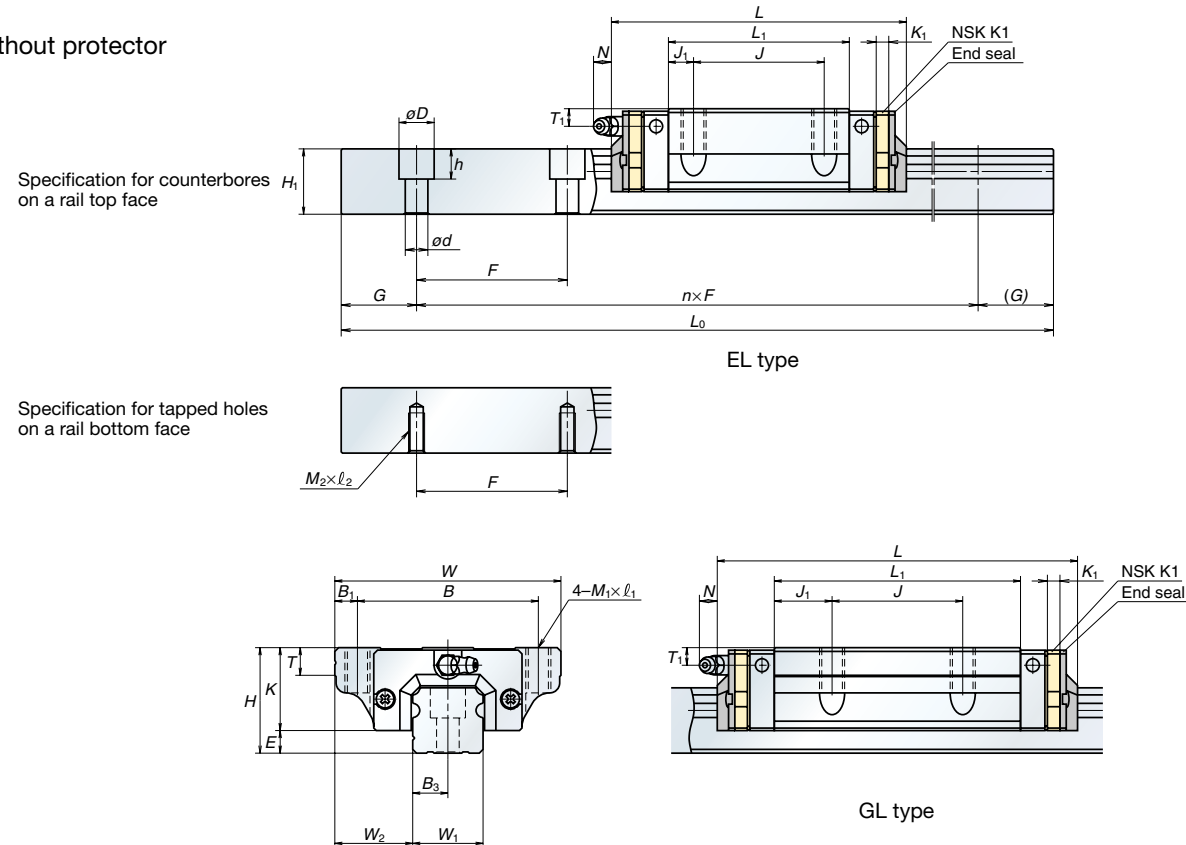

● With protector

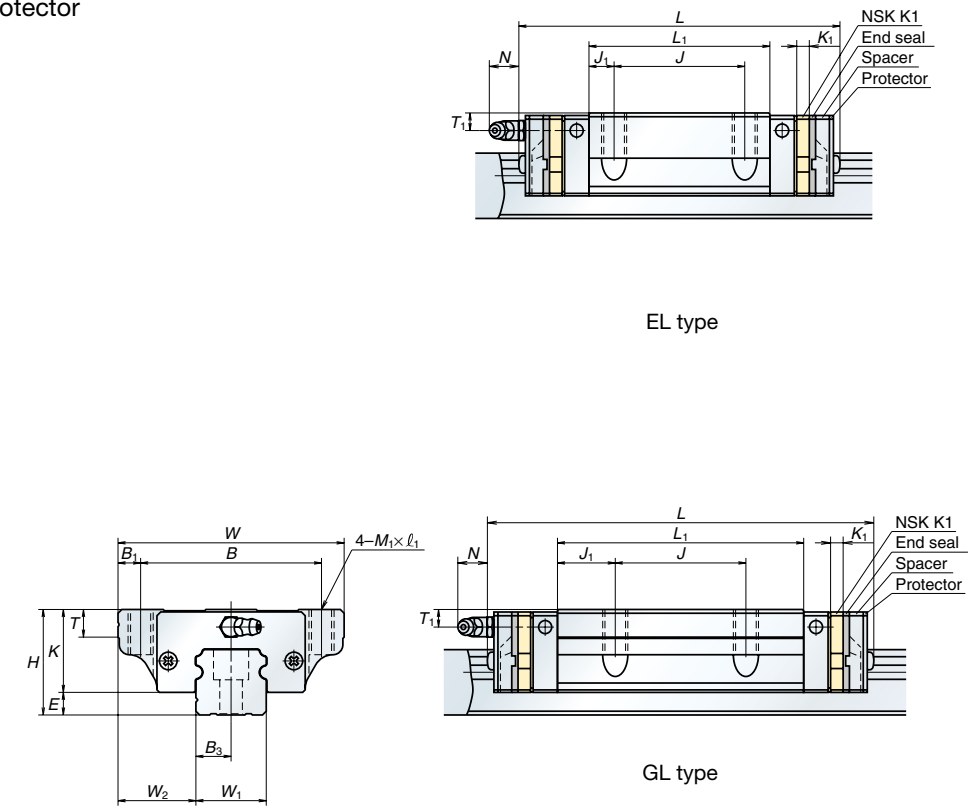

Table 11 Dimensions

Unit: mm

Model No.	Assembly			Roller slide											Rail					Basic load rating					Ball diameter D_w	Weight							
	Height H	E	W_2	Width W	Length L	Tapped mounting hole			Grease nipple					Rail width W_1	Rail height H_1	Pitch F	Counterbore $d \times D \times h$	Tapped hole $M_2 \times \text{Pitch} \times l_2$	B_3	G (recommended)	Maximum length L_{Omax}	Dynamic $C(N)$	Static $C_0(N)$	Static moment (N-m)			Ball slide (kg)	Rail (kg/m)					
						B	J	$M_1 \times \text{Pitch} \times l_1$	B_1	L_1	J_1	K	T											K_1		Mounting hole			T_1	N	M_{R0}	M_{P0}	M_{V0}
VH15EL VH15GL	24	4.6	16	47	70.6 (77) 89.6 (96)	38	30	M5×0.8×8	4.5	39	4.5	19.4	8	4.5	$\phi 3$	4.5	1 (8.2)	15	15	60	4.5×7.5×5.3	M5×0.8×8	7.5	20	2 000 [1 800]	10 800 14 600	20 700 32 000	108 166	95 216	80 181	3.175	0.17 0.25	1.6
VH20EL VH20GL	30	5	21.5	63	87.4 (94.2) 109.4 (116.2)	53	40	M6×1×10	5	50	5	25	10	4.5	M6×0.75	5	11.1 (12.3)	20	18	60	6×9.5×8.5	M6×1×10	10	20	3 960 [3 500]	17 400 23 500	32 500 50 500	219 340	185 420	155 355	3.968	0.45 0.65	2.6
VH25EL VH25GL	36	7	23.5	70	97 (104.4) 125 (132.4)	57	45	M8×1.25×16 [M8×1.25×12]	6.5	58	6.5	29	11	5	M6×0.75	6	9.6 (12.9)	23	22	60	7×11×9	M6×1×12	11.5	20	3 960 [3 500]	25 600 34 500	46 000 71 000	360 555	320 725	267 610	4.762	0.63 0.93	3.6
VH30EL VH30GL	42	9	31	90	117.4 (127.8) 143.4 (153.8)	72	52	M10×1.5×18 [M10×1.5×15]	9	72	10	33	11	5	M6×0.75	7	11.4 (14.2)	28	26	80	9×14×12	M8×1.25×15	14	20	4 000 [3 500]	35 500 46 000	63 000 91 500	600 870	505 1 030	425 865	5.556	1.2 1.6	5.2
VH35EL VH35GL	48	9.5	33	100	128.8 (139.2) 162.8 (173.2)	82	62	M10×1.5×20	9	80	9	38.5	12	5.5	M6×0.75	8	10.9 (13.7)	34	29	80	9×14×12	M8×1.25×17	17	20	4 000	47 500 61 500	80 500 117 000	950 1 380	755 1 530	630 1 280	6.350	1.7 2.4	7.2
VH45EL VH45GL	60	14	37.5	120	161.4 (174.2) 193.4 (206.2)	100	80	M12×1.75×24	10	105	12.5	46	13	6.5	Rc1/8	10	12.5 (14.1)	45	38	105	14×20×17	M12×1.75×24	22.5	22.5	3 990	81 000 99 000	140 000 187 000	2 140 2 860	1 740 3 000	1 460 2 520	7.937	3.0 3.9	12.3
VH55EL VH55GL	70	15	43.5	140	185.4 (198.2) 223.4 (236.2)	116	95	M14×2×28	12	126	15.5	55	15	6.5	Rc1/8	11	12.5 (14.1)	53	44	120	16×23×20	M14×2×24	26.5	30	3 960	119 000 146 000	198 000 264 000	3 600 4 850	3 000 5 150	2 510 4 350	9.525	5.0 6.5	16.9

Figure inside < > is the dimension when equipped with the protector.

Figure inside [] is applied to stainless products.

V1 Series Dimensions

- VH-FL (high load/low type)
- VH-EM (high load/low type)
- VH-HL (super high load/low type)
- VH-GM (super high load/low type)

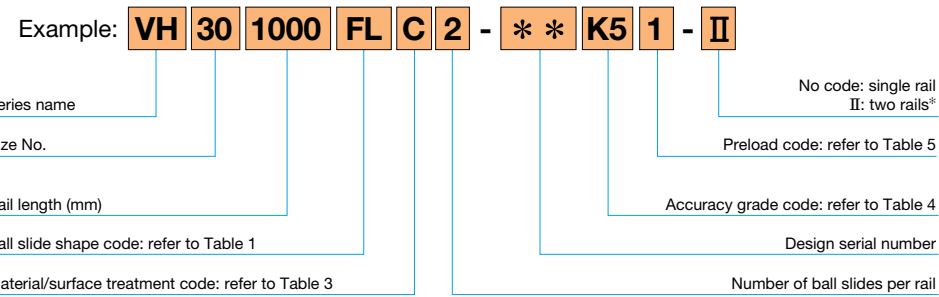

* Please note that the appropriate design number will be inserted into the reference number and the end code (-II) will be omitted.

● Without protector

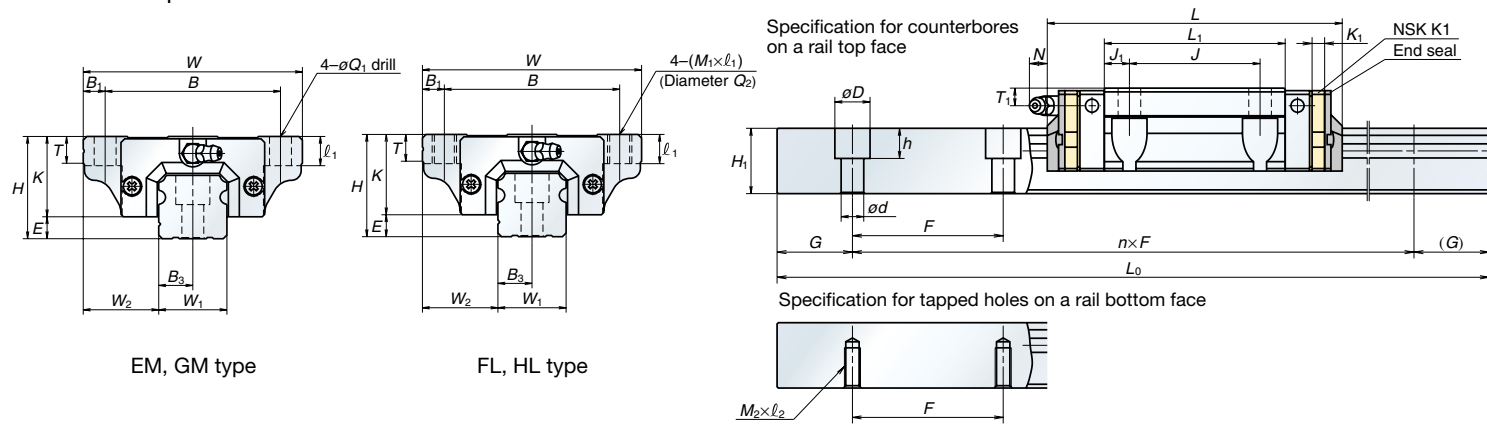

● With protector

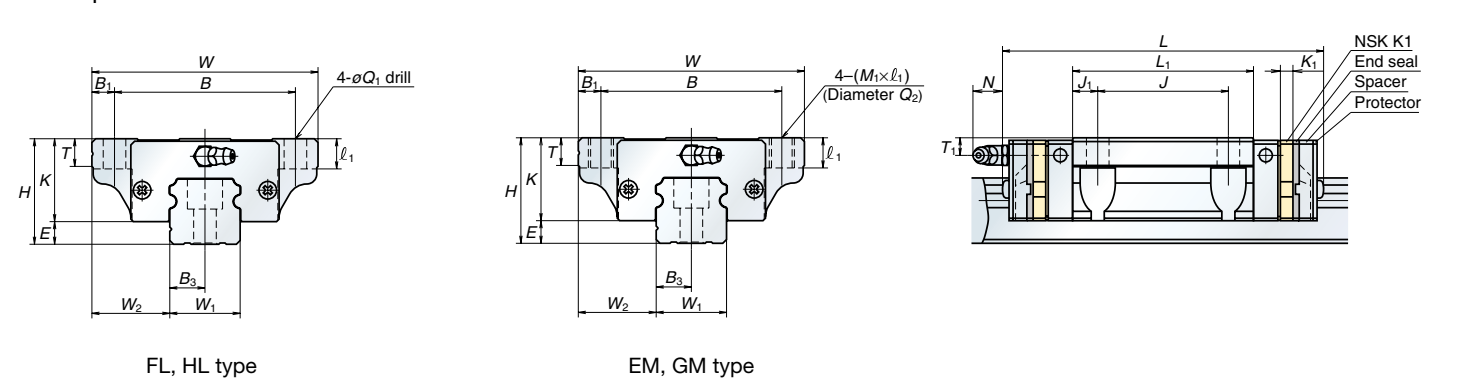

Table 12 Dimensions

Unit: mm

Model No.	Assembly			Roller slide													Rail					Basic load rating					Ball diameter		Weight					
	Height H	E	W ₂	Width W	Length L	Tapped mounting hole			Q ₂	B ₁	L ₁	J ₁	K	T	K ₁	Grease nipple			Rail width W ₁	Rail height H ₁	Pitch F	Counterbore d×D×h	Tapped hole M ₂ ×Pitch×L ₂	B ₃	G (recommended)	Maximum length L _{max}	Dynamic C (N)	Static C ₀ (N)	Static moment (N·m)			D _w	Ball slide (kg)	Rail (kg/m)
						B	J	M ₁ ×Pitch×L ₁								Mounting hole	T ₁	N											M _{F0}	M _{P0}	M _{V0}			
VH15FL VH15EM VH15HL VH15GM	24	4.6	16	47	70.6 (77) 89.6 (96)	38	30	M5×0.8×7 4.5×7	4.4	4.5	4.5	19.4	8	4.5	φ3	4.5	1	< 8.2	15	15	60	4.5×7.5×5.3	M5×0.8×8	7.5	20	2 000 [1 800]	10 800 14 600	20 700 32 000	108 166	95 216	80 181	3.175	0.17 0.25	1.6
VH20FL VH20EM VH20HL VH20GM	30	5	21.5	63	87.4 (94.2) 109.4 (116.2)	53	40	6×9.5 M6×1.0×9.5 6×9.5 M6×1.0×9.5	5.3	5	5	25	10	4.5	M6×0.75	5	11.1 (12.3)	20	18	60	6×9.5×8.5	M6×1×10	10	20	3 960 [3 500]	17 400 23 500	32 500 50 500	219 340	185 420	155 355	3.968	0.45 0.65	2.6	
VH25FL VH25EM VH25HL VH25GM	36	7	23.5	70	97 (104.4) 125 (132.4)	57	45	7×10 [7×11.5] M8×1.25×10 [M8×1.25×11.5] 7×10 [7×11.5] M8×1.25×10 [M8×1.25×11.5]	6.8	6.5	6.5	29	11 [12]	5	M6×0.75	6	9.6 (12.9)	23	22	60	7×11×9	M6×1×12	11.5	20	3 960 [3 500]	25 600 34 500	46 000 71 000	360 555	320 725	267 610	4.762	0.63 0.93	3.6	
VH30FL VH30EM VH30HL VH30GM	42	9	31	90	117.4 (127.8) 143.4 (153.8)	72	52	9×12 [9×14.5] M10×1.5×12 [M10×1.5×14.5] 9×12 [9×14.5] M10×1.5×12 [M10×1.5×14.5]	8.6	9	9	33	11 [15]	5	M6×0.75	7	11.4 (14.2)	28	26	80	9×14×12	M8×1.25×15	14	20	4 000 [3 500]	35 500 46 000	63 000 91 500	600 870	505 1 030	425 865	5.556	1.2 1.6	5.2	
VH35FL VH35EM VH35HL VH35GM	48	9.5	33	100	128.8 (139.2) 162.8 (173.2)	82	62	9×13 M10×1.5×13 9×13 M10×1.5×13	8.6	9	9	38.5	12	5.5	M6×0.75	8	10.9 (13.7)	34	29	80	9×14×12	M8×1.25×17	17	20	4 000	47 500 61 500	80 500 117 000	950 1 380	755 1 530	630 1 280	6.350	1.7 2.4	7.2	
VH45FL VH45EM VH45HL VH45GM	60	14	37.5	120	161.4 (174.2) 193.4 (206.2)	100	80	11×15 M12×1.75×15 11×15 M12×1.75×15	10.5	10	10	46	13	6.5	Rc1/8	10	12.5 (14.1)	45	38	105	14×20×17	M12×1.75×24	22.5	22.5	3 990	81 000 99 000	140 000 187 000	2 140 2 860	1 740 3 000	1 460 2 520	7.937	3.0 3.9	12.3	
VH55FL VH55EM VH55HL VH55GM	70	15	43.5	140	185.4 (198.2) 223.4 (236.2)	116	95	14×18 M12×2.0×18 14×18 M14×2.0×18	12.5	12	12	55	15	6.5	Rc1/8	11	12.5 (14.1)	53	44	120	16×23×20	M14×2×24	26.5	30	3 960	119 000 146 000	198 000 264 000	3 600 4 850	3 000 5 150	2 510 4 350	9.525	5.0 6.5	16.9	

Figure inside < > is the dimension when equipped with the protector. Figure inside [] is applied to stainless products.