

Support Units for Light Load and Small Equipment

Clean support unit featuring proven low dust emissions and low torque. The new series is bolstered by higher antirust properties and a wider lineup.

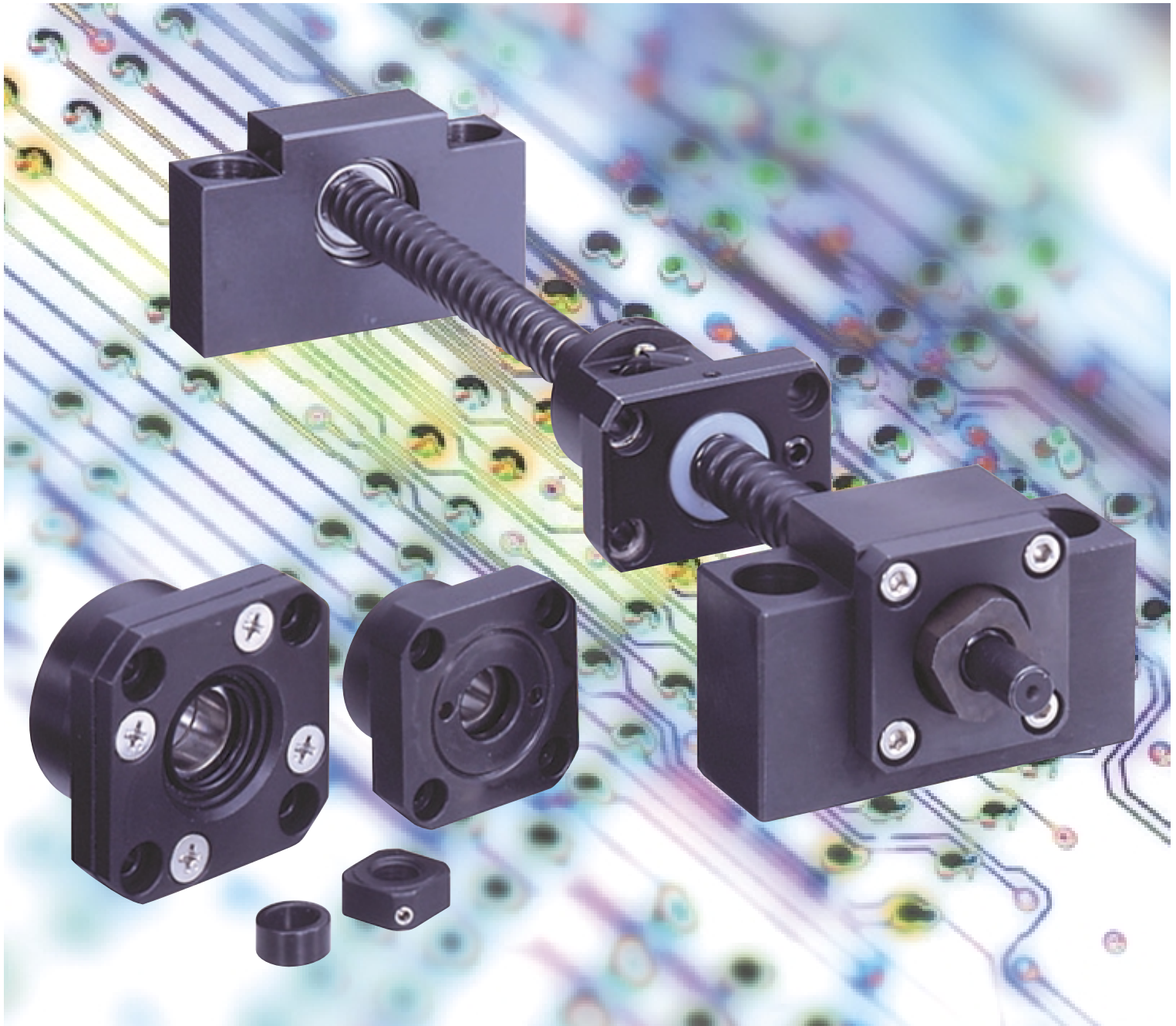

Patent Pending



Support units for light load and small equipment provide both fixed and support side bearing assemblies to support screw shafts. They provide all required parts such as bearing locknuts so that you can mount them directly to NSK standard ball screws, of which shaft ends are machined.

Please refer to the dimensions listed on the dimension table for configuration of standard screw shaft ends for NSK standard ball screws with blank shaft ends. For rolled ball screws, you require optional spacers when mounting fixed support side support units.

Features

Prompt delivery

All support units are standard stocked items.

Best selection of bearings for your application

General use support units for fixed support side are equipped with highly rigid angular contact ball bearings that have been assembled with proper preload, and packed with the appropriate volume of grease. On the other hand, clean support units for fixed support side uses low dust emission grease, and low torque special bearings. Sealed deep groove ball bearings are used for simple support side units for both general and clean environment use.

Accessories

Support units provide everything necessary for mounting ball screws to machines.

(Please refer to the table on the right.)

* Do not disassemble fixed support side units as they are equipped with bearings and oil seals.

Antirust treatment

The table on the right shows the surface treatment for the bearing housing, and material of small parts.

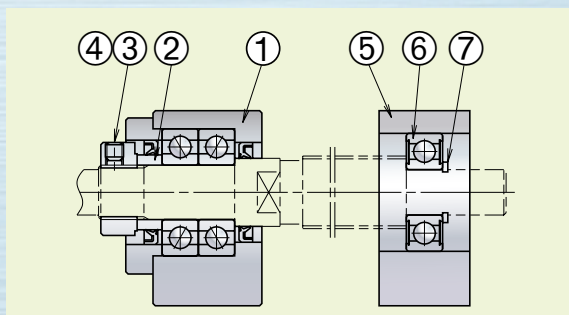

Fixed support side		Simple support side	
Part no.	Name of parts	Part no.	Name of parts
①	Bearing housing	⑤	Bearing housing
②	Spacer	⑥	Bearing
③	Locknut	⑦	Snap ring
④	Set screw with set piece		

General support unit	
Bearings and grease	Angular contact ball bearings, PS2
Surface treatment	Black oxide
Screws and snap rings	Standard material

Specifications of support unit for general use

Reference no.	Fixed support side support unit				Simple support side support unit		
	Axial direction			Maximum starting torque [N·cm]	Reference no.	Bearing reference no.	Radial direction
	Basic dynamic load rating C_a [N]	Load limit [N]	Stiffness [N/μm]				Basic dynamic load rating C [N]
WBK06-01A (square) WBK06-11 (round)	2 670	1 040	28	0.49	—	—	—
WBK08-01A (square) WBK08-11 (round)	4 400	1 450	53	0.88	WBK08S-01 (square)	606ZZ	2 260
WBK10-01A (square) WBK10-11 (round)	6 600	2 730	94	1.9	WBK10S-01 (square)	608ZZ	3 300
WBK12-01A (square) WBK12-11 (round)	7 100	3 040	104	2.1	WBK12S-01 (square)	6000ZZ	4 550
WBK15-01A (square) WBK15-11 (round)	7 600	3 380	113	2.3	WBK15S-01 (square)	6002ZZ	5 600
WBK17-01A (square)	13 400	5 800	148	2.8	WBK17S-01 (square)	6203ZZ	9 550
WBK20-01 (square) WBK20-11 (round)	17 900	8 240	155	5.4	WBK20S-01 (square)	6204ZZ	12 800
WBK25-01 (square) WBK25-11 (round)	20 200	10 000	192	7.2	WBK25S-01 (square)	6205ZZ	14 000
WBK04R-11 (round)	615	490	6.5	0.59	—	—	—
WBK06R-11 (round)	1 280	930	9	0.59	—	—	—

New

Features of Clean Support Unit

Outstanding low dust emission

Clean support unit uses “NSK clean grease LG2” which has a proven feature of low dust emission. It reduces dust emission to 1/10 of general support units.

Low torque

It features low torque characteristics because of special bearings. (50% lower than general support unit.)

High antirust specification

Low temperature chrome plating is applied to bearing housings, retaining plates, locknuts and spacers to improve antirust properties. Moreover, bolts and snap rings are made of stainless steel.

The table below shows the surface treatment of the bearing housing and material of small parts.

	Clean support unit
Bearing-grease	Special bearings, LG2
Surface treatment	Low temperature chrome plating
Set screw and snap ring material	Stainless steel

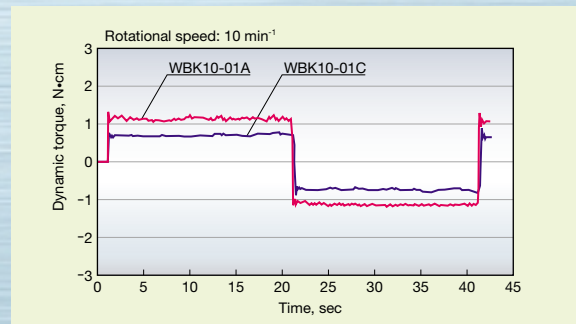
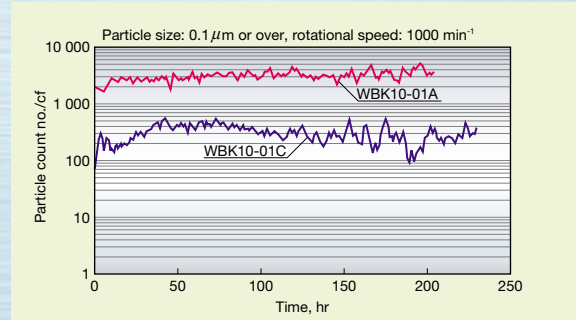

Clean support unit specifications

Fixed support side support unit					Simple support side support unit		
Reference no.	Axial direction			Maximum starting torque [N·cm]	Reference no.	Bearing reference no.	Radial direction
	Basic dynamic load rating C _a [N]	Load limit [N]	Stiffness [N/μm]				Basic dynamic load rating C [N]
WBK08-01C (square)	3 100	1 100	36	0.52	WBK08S-01C	606VV	2 260
WBK08-11C (round)							
WBK10-01C (square)	4 250	1 364	50	1.1	WBK10S-01C	608VV	3 300
WBK10-11C (round)							
WBK12-01C (square)	4 700	2 443	57	1.2	WBK12S-01C	6000VV	4 550
WBK12-11C (round)							
WBK15-01C (square)	5 100	2 757	63	1.3	WBK15S-01C	6002VV	5 600
WBK15-11C (round)							

Configuration of reference number

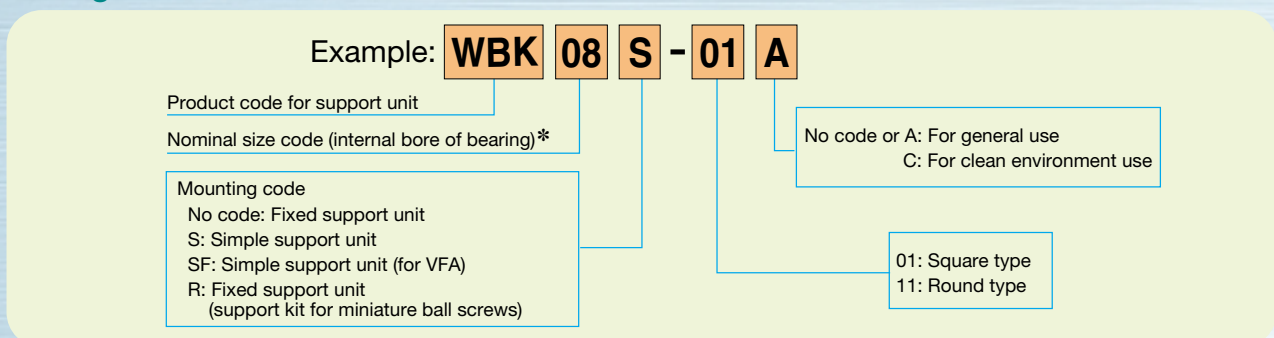

* In case of simple support unit, be careful that 12 or less size codes do not represent internal bores of bearing. Please refer to the dimensional table for internal bore of bearing.

Dimensions of Square Type Support Unit

Fixed support side support unit (square type)

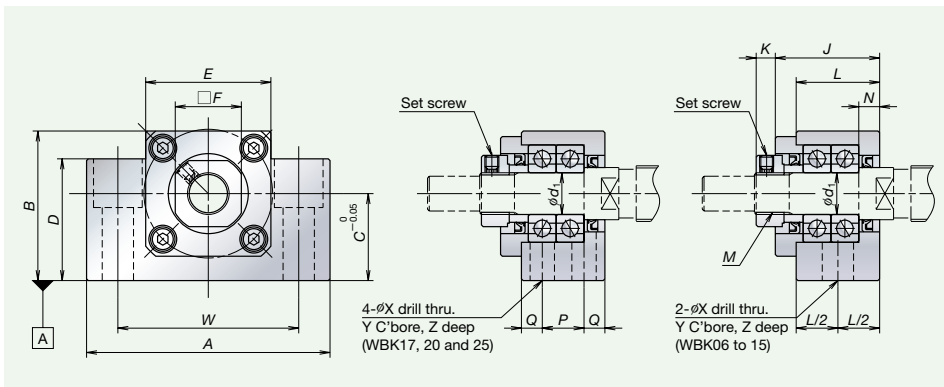

Reference no.	Locknut tightening torque (reference) [N•cm]	Set screw tightening torque (reference) [N•cm]
WBK06- **	245	69 (M3)
WBK08- **	490	69 (M3)
WBK10- **	930	147 (M4)
WBK12- **	1 370	147 (M4)
WBK15- **	2 350	147 (M4)
WBK17- **	3 145	147 (M4)
WBK20- **	4 700	147 (M4)
WBK25- **	8 400	490 (M6)

Units: mm

Reference no.		Fixed support side support unit (square type)																	
For general use	For clean environment use	d_1	A	B	C	D	E	F	J	K	L	N	P	Q	W	X	Y	Z	M
WBK06-01A	————	6	42	25	13	20	18	12	20	5.5	—	3.5	—	—	30	5.5	9.5	11	M6 × 0.75
WBK08-01A	WBK08-01C	8	52	32	17	26	25	14	23	7	—	4	—	—	38	6.6	11	12	M8 × 1
WBK10-01A	WBK10-01C	10	70	43	25	35	36	17	30	5.5	24	6	—	—	52	9	14	11	M10 × 1
WBK12-01A	WBK12-01C	12	70	43	25	35	36	19	30	5.5	24	6	—	—	52	9	14	11	M12 × 1
WBK15-01A	WBK15-01C	15	80	50	30	40	41	22	31	12	25	5	—	—	60	11	17	15	M15 × 1
WBK17-01A	————	17	86	64	39	55	50	24	44	7	35	7	19	8	68	9	14	11	M17 × 1
WBK20-01	————	20	95	58	30	45	56	30	52	10	42	10	22	10	75	11	17	15	M20 × 1
WBK25-01	————	25	105	68	35	25	66	36	61	13	48	14	30	9	85	11	No counter bores		M25 × 1.5

Simple support side support unit

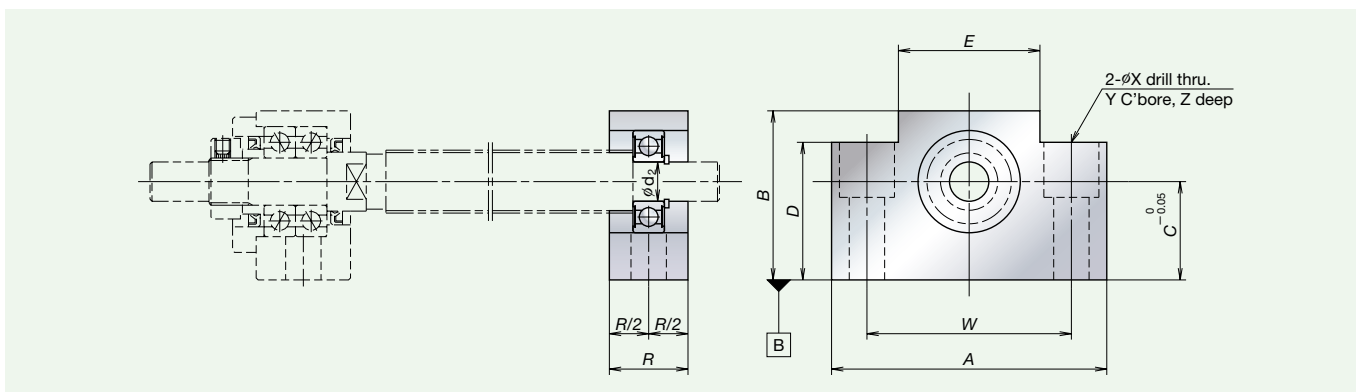

Units: mm

Reference no.		Simple support side support unit (square type)										
For general use	For clean environment use	d_2	R	A	B	C	D	E	W	X	Y	Z
WBK08S-01	WBK08S-01C	6	15	52	32	17	26	25	38	6.6	11	12
WBK10S-01	WBK10S-01C	8	20	70	43	25	35	36	52	9	14	11
WBK12S-01	WBK12S-01C	10	20	70	43	25	35	36	52	9	14	11
WBK15S-01	WBK15S-01C	15	20	80	50	30	40	41	60	9	14	11
WBK17S-01	————	17	23	86	64	39	55	50	68	9	14	11
WBK20S-01	————	20	26	95	58	30	45	56	75	11	17	15
WBK25S-01	————	25	30	105	68	35	25	66	85	11	No counter bores	

Dimensions of Round Type and Miniature Support Unit

Fixed support side support unit (round type)

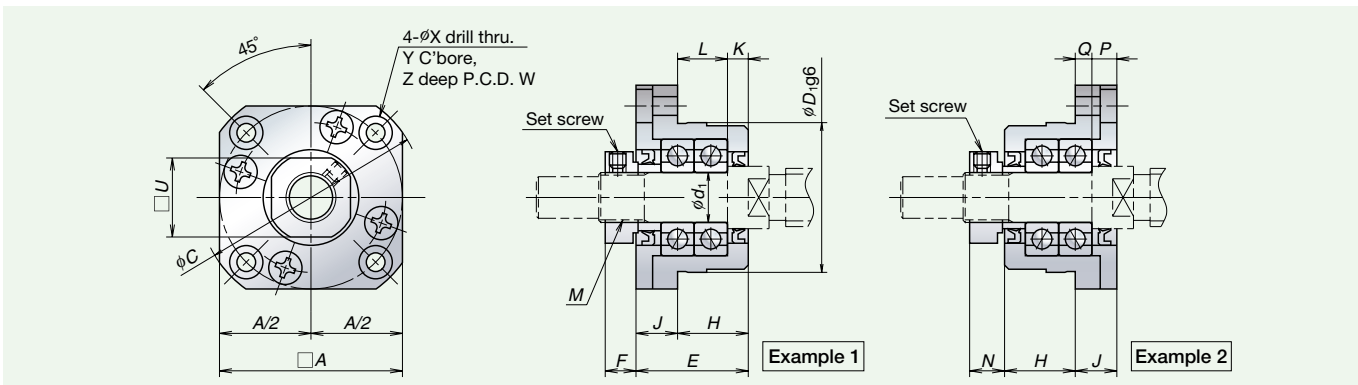

Units: mm

Reference no.		Fixed support side support unit (round type)																		
For general use	For clean environment use	d_1	A	C	D_1	E	F	H	J	K	L	N	P	Q	U	W	X	Y	Z	M
WBK06-11	—————	6	28	35	22	20	5.5	13	7	3.5	9.5	6.5	4.5	2.5	12	28	2.9	5.5	3.5	M6 × 0.75
WBK08-11	WBK08-11C	8	35	43	28	23	7	14	9	4	10	8	5	4	14	35	3.4	6.5	4	M8 × 1
WBK10-11	WBK10-11C	10	42	52	34	27	7.5	17	10	5	12	8.5	6	4	17	42	4.5	8	4	M10 × 1
WBK12-11	WBK12-11C	12	44	54	36	27	7.5	17	10	5	12	8.5	6	4	19	44	4.5	8	4	M12 × 1
WBK15-11	WBK15-11C	15	52	63	40	32	12	17	15	6	11	14	8	7	22	50	5.5	9.5	6	M15 × 1
WBK20-11	—————	20	68	85	57	52	10	30	22	10	20	14	14	8	30	70	6.6	11	10	M20 × 1
WBK25-11	—————	25	79	98	63	57	13	30	27	10	20	20	17	10	36	80	9	15	13	M25 × 1.5

* Refer to the table of square type for tightening torque of locknuts and setscrews.

Notes:

1. Use datum face A or B to mount a square type support unit to a machine base.
2. Tighten a set screw after a locknut is adjusted and tightened.
3. Insert the set piece that is provided with support unit to a screw hole, and then tighten the set screw.

Support kits for miniature ball screws

Support kits are for the RMS precision rolled miniature ball screw series. However, please use support units for general use in case of RMA1002 or larger rolled ball screws.

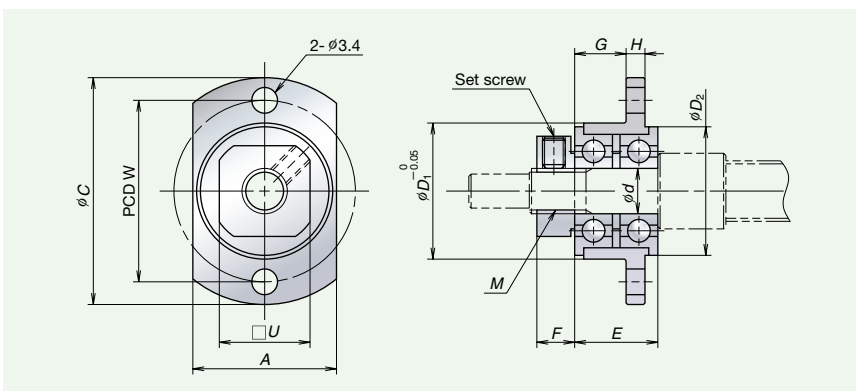

Notes:

1. Oscillate bearings slowly so that they fall into a place to make run-out of mounting face minimal, and then tighten a locknut.
2. A support kit is put on a provisional shaft (bolt) for shipping.

Units: mm

Reference no.	A	C	d	D_1	D_2	E	F	G	H	W	U	M	Applicable ball screw	Locknut tightening torque (reference) [N·cm]	Setscrew tightening torque (reference) [N·cm]
WBK04R-11	14	25	4	13	12.5	9	5	5	2.5	19	10	M4 × 0.5	RMA0601	147	38 (M2.5)
WBK06R-11	19	30	6	18	17	11	5	6.8	2.5	24	12	M6 × 0.75	RMA0801 RMA0801.5 RMA0802	245	69 (M3)

Simple support side support units for VFA ball screws

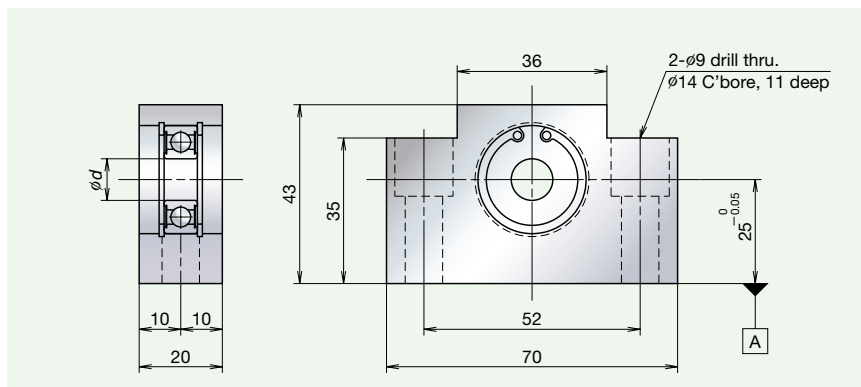

Units: mm

Reference no.	d	Applicable ball screw
WBK12SF-01	12	VFA1210
WBK15SF-01	15	VFA1510 VFA1520

Notes:

1. Use datum face A for mounting to a machine base.
2. This type is exclusively made for simple support side units for NSK VFA ball screws. This unit supports a ball screw outside of a screw shaft.

Dimensions of Locknut

Locknut

It is essential to align a ball screw to exhibit its full performance. For this reason, we provide standard locknuts exclusive for ball screws, of which perpendicularities are controlled against the screw thread.

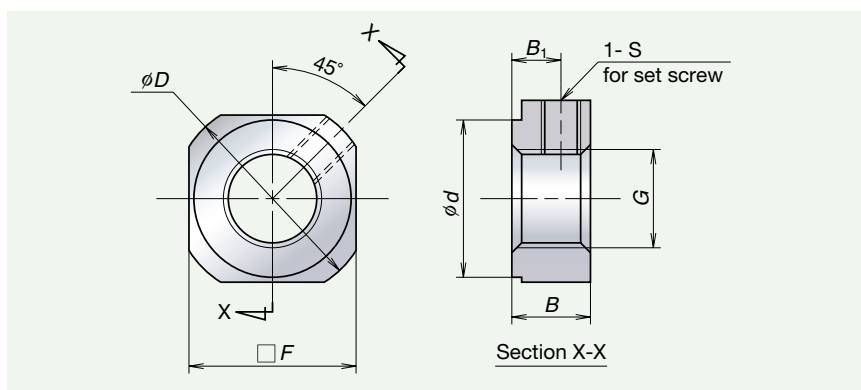

Notes:

1. Fasten the set screw after adjusting run-out of support kit and tightening a locknut.
2. Insert the set piece (bras pad) that is provided with a support kit, and then fasten the set screw.

Units: mm

Reference no.	G	D	F	B	d	B_1	S	Locknut tightening torque (reference) [N·cm]	Set screw tightening torque (reference) [N·cm]
WBK06L-01	M6×0.75	14.5	12	5	10	2.7	M3	245	69 (M3)
WBK08L-01	M8×1	17	14	6.5	13	4	M3	490	69 (M3)
WBK10L-01	M10×1	20	17	8	16	5	M4	930	147 (M4)
WBK12L-01	M12×1	22	19	8	17	5	M4	1 370	147 (M4)
WBK15L-01	M15×1	25	22	10	21	6	M4	2 350	147 (M4)
WBK17L-01	M17×1	29	24	13	24	8	M4	3 145	147 (M4)
WBK20L-01	M20×1	35	30	13	26	8	M4	4 700	147 (M4)
WBK25L-01	M25×1.5	42	36	16	34	10	M6	8 400	490 (M6)

Dimensions of Spacer

Spacer

It requires an optional spacer to the side where ball thread is cut through, such as a rolled ball screw shaft when mounting the support unit for fixed support side.

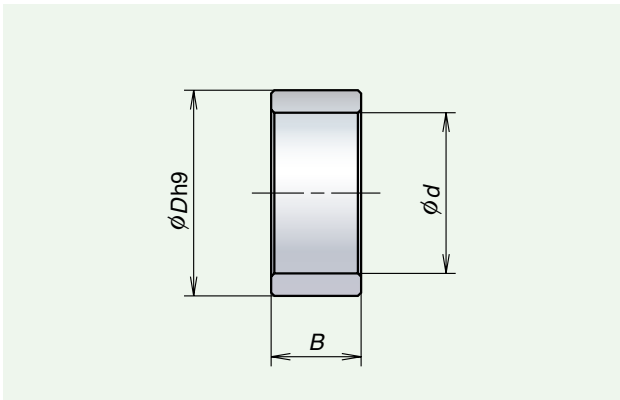

Units: mm

Reference no.	Internal diameter, d	Outside diameter, D	Width B	Applicable support unit
WBK06K	6	9.5	5.0	WBK06- **
WBK08K	8	11.5	5.5	WBK08- **
WBK10K	10	14.5	5.5	WBK10- **
WBK12K	12	15.0	5.6	WBK12- **
WBK15K	15	19.5	10.0	WBK15- **
WBK17K	17	24.4	7.0	WBK17- **
WBK20K	20	25.5	11.0	WBK20- **
WBK25K	25	32.0	14.0	WBK25- **

Dimensions of Screw Shaft End Configuration

Screw shaft end configuration

Dimensions of shaft end configurations are shown on the table below for the light load and small equipment support units. Add a spacer width (B on the above table for spacers) to L_1 dimension below when using a spacer for a rolled ball screw.

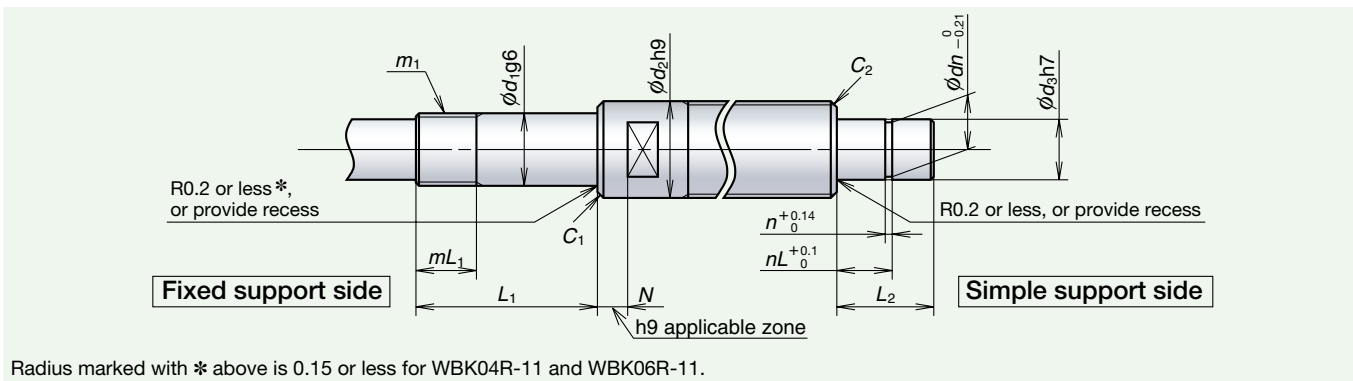

Radius marked with * above is 0.15 or less for WBK04R-11 and WBK06R-11.

Units: mm

Reference no.	Fixed support side							Simple support side						
	Bearing journal	Locknut thread	Sealing part		Chamfer		Reference no.	Bearing journal	Snap ring groove		Chamfer			
	d_1	L_1	m_1	mL_1	d_2	N	C_1		d_3	L_2	n	dn	nL	C_2
WBK06- **	6	22.5	M6 × 0.75	7	9.5	3.5	0.2	—	—	—	—	—	—	—
WBK08- **	8	27	M8 × 1	9	11.5	4	0.2	WBK08S- **	6	9	0.8	5.7	6.8	0.2
WBK10- **	10	30	M10 × 1	10	14	6	0.2	WBK10S- **	8	10	0.9	7.6	7.9	0.2
WBK12- **	12	30	M12 × 1	10	15	6	0.2	WBK12S- **	10	22	1.15	9.6	9.15	0.5
WBK15- **	15	40	M15 × 1	15	19.5	5	0.3	WBK15S- **	15	25	1.15	14.3	10.15	0.5
WBK17- **	17	46	M17 × 1	17	24	7	0.3	WBK17S- **	17	16	1.15	16.2	13.15	0.5
WBK20- **	20	53	M20 × 1	16	25	10	0.3	WBK20S- **	20	19	1.35	19	15.35	0.5
WBK25- **	25	62	M25 × 1.5	20	32	14	0.5	WBK25S- **	25	20	1.35	23.9	16.35	0.5
WBK04R-11	4	15	M4 × 0.5	7.5	—	—	0.3	Regarding support units for heavy loads and machine tools, please refer to the Catalog "Precision Machine Components."						
WBK06R-11	6	17	M6 × 0.75	7.5	—	—	0.3							